



Source: Knoxville BMP Manual, 2003.

Description

Training programs ensure that all employees understand the requirements of the Storm Water Management Program Plan as applicable to their responsibilities. Training topics include but are not limited to storm water management, potential contamination sources, and BMPs.

Applications

Employees involved in the planning, design, or construction phase of construction, repair, or maintenance activities within the HDOT Highways rights-of-way.

Implementation Requirements

- Provide storm water management training through courses, seminars, workshops, product demonstrations, employee meetings, posters, and bulletin boards.
- Provide field training programs conducted by trained personnel.
- Maintain commitment and request input from senior DOT and Highways Division management.
- Promote open communication between employees involved in various stages of the projects.
- Improve storm water quality management based on past experience involving water quality problems at construction sites. Implement revised practices and procedures in training.
- Increase employee awareness of requirements and procedures for BMP monitoring and reporting.
- Develop standard operating procedures for storm water quality management.
- Conduct spill drills.

Employee Training

SM-1

Limitations

- Training performance depends on the degree of employee motivation and incentive to learn about BMP implementation; and
- The availability of staff time to coordinate and conduct training.

Inspections and Maintenance

Provide annual training on construction BMP implementation for all employees involved with construction activities.

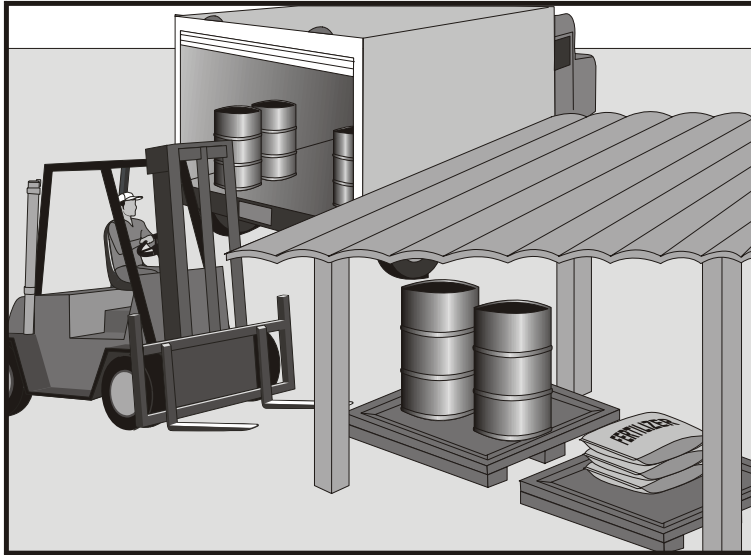

Source: Caltrans Construction Site Best Management Practices Manual, 2003.

Description

Practices and procedures that promote proper handling and storage of construction materials to prevent or reduce storm water pollution, injury to workers or visitors, groundwater pollution, and soil contamination.

Applications

Storage and handling activities on construction sites involving one of the following:

- Soil;
- Soil stabilizers and binders;
- Fertilizers;
- Pesticides and herbicides;
- Detergents;
- Plaster;
- Hazardous chemicals such as acids, lime, glues, paints, solvents, and curing compounds;
- Petroleum products such as fuel, oil, and grease; and
- Asphalt and concrete products.

Installation and Implementation Requirements

- Provide training for employees and contractors on proper material delivery and storage practices and procedures.
- Designate on-site material delivery and storage areas. Areas shall be located near construction entrances and away from watercourses. Earth berms or other containment measures shall surround storage areas.

Installation and Implementation Requirements (Continued)

- Flammable materials shall comply with the fire codes of Honolulu. Contact the local Fire Marshal for site specific requirements. Refer to the Flammable and Combustible Liquid Code, NFPA30 for more information.
- Maintain accurate and up to date records of material delivered and stored on-site.
- Minimize on-site inventory.
- Retain a complete set of material safety data sheets on-site.
- Minimize handling of hazardous materials.
- Store materials under cover during the rainy season.
- Store chemicals, drum, and bagged materials on a pallet and when possible, under cover in secondary containment.
- If drums must be stored in an uncovered area, place them at a slight angle to minimize ponding of rainwater on the lids to minimize corrosion.
- Hazardous chemicals shall be well-labeled and stored in the original containers.
- Employees with emergency spill cleanup training shall be present during unloading of dangerous materials or liquid chemicals.
- Any significant residual materials remaining on the ground after the completion of construction shall be removed and properly disposed. If the residual materials contaminate the soil, then the contaminated soil shall also be removed and properly disposed.

Limitations

Storage sheds shall comply with building and fire code requirements.

Inspections and Maintenance

- Storage areas shall be clean and well organized.
- An ample supply of spill cleanup materials shall be kept with work crew supplies.
- Conduct weekly inspections of material containers for corrosion.
- Conduct weekly inspections of storage areas which may require repair or replacement.

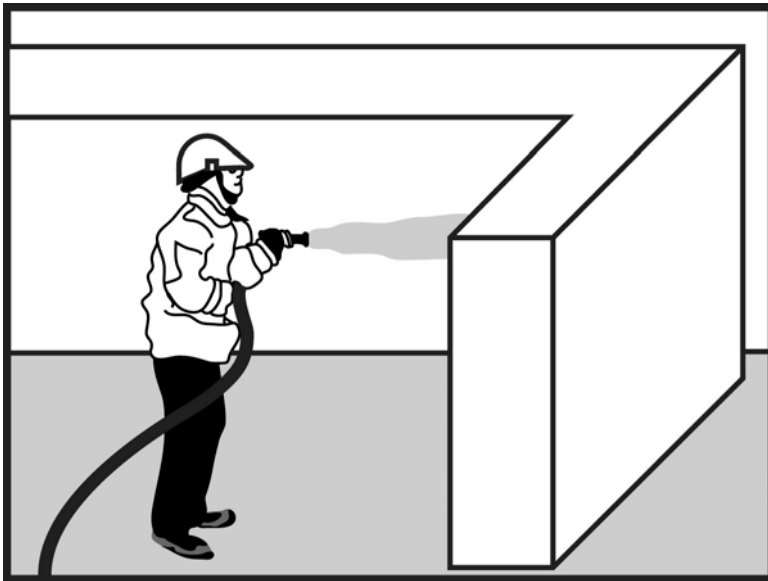

Source: Modified from Caltrans Construction Site Best Management Practices Manual, 2003.

Description Minimizing or eliminating the discharge of pollutants to the storm drain system or adjacent water bodies by reducing hazardous material use on-site, using alternative products, and training employees in proper handling and use of construction materials.

Applications Activities involving use of one of the following materials:

- Fertilizers;
- Detergents;
- Herbicides;
- Plaster;
- Petroleum products such as oil, fuel, and grease;
- Soil stabilizers and binders;
- Asphalt and concrete components; and
- Other hazardous materials such as acids, lime, glues, adhesives, paints, solvents, and curing compounds.

Installation and Implementation Requirements

- Restrict use of materials to only when and where necessary to complete the construction activity.
- Reduce or eliminate on-site use of hazardous materials. Refer to SM-9 (Hazardous Waste Management) in this manual for more information regarding use of hazardous materials.
- Carefully select appropriate material needed for the task.
- Do not remove the original label. Comply with manufacturer's labels, which include product information regarding uses, protective equipment, flammability, ventilation, and mixing of chemicals.

Installation and Implementation Requirements (Continued)

- Dispose container only after all of the product has been used.
- Restrict amount of herbicide prepared to quantity necessary for the current application. Comply with the recommended usage instructions. Do not apply fertilizers or herbicides during or just before a rain event.
- An ample supply of cleanup materials for spills shall be readily accessible.
- Provide employee training on proper material use.

Limitations

Alternative materials may not be available or appropriate for certain construction activities.

Inspections and Maintenance

- Provide training to all new employees at the beginning of their employment.
- Provide periodic training to all employees involved in handling construction materials.

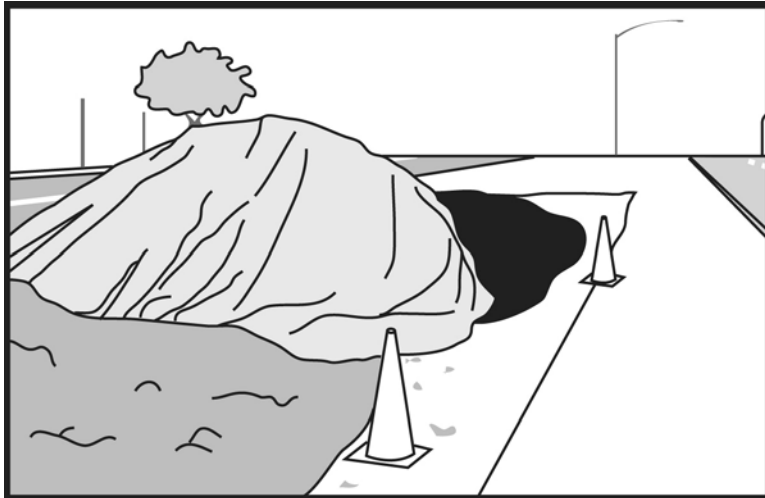

Description	Stockpile protection measures reduce the potential for air and storm water pollution originating from stockpiles of construction materials, including soil and paving materials.
Applications	Projects requiring stockpiles of construction materials.
Installation and Implementation Requirements	<ul style="list-style-type: none">• Stockpiles shall be located a minimum of 50 feet away from concentrated runoff.• Place bagged materials on pallets and under cover.• Provide physical diversion to protect stockpiles from concentrated runoff.• Cover stockpiles with plastic or comparable material prior to a rain event and during the rainy season.• Place silt fence, fiber filtration tubes, or straw wattles around stockpiles.
Limitations	Stockpiles are only applicable for temporary storage of material.
Inspections and Maintenance	Periodic replacement and repair of materials used for stockpile protection.

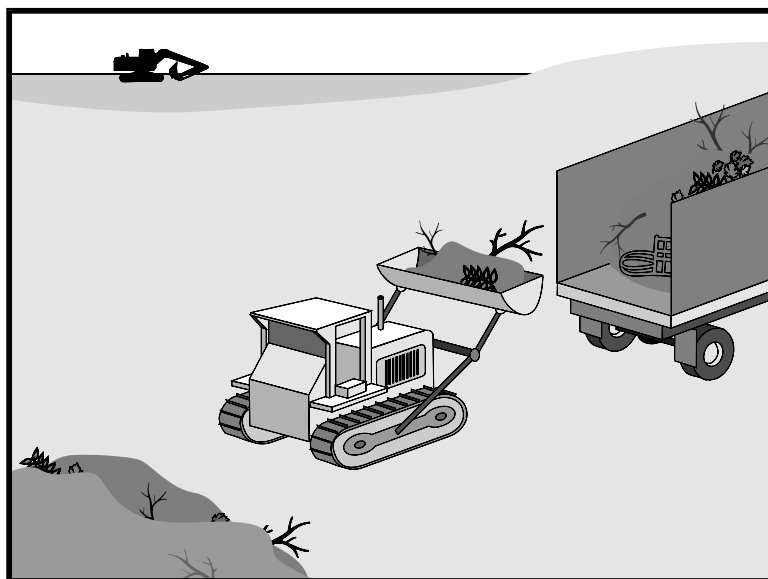

Source: Caltrans Construction Site Best Management Practices Manual, 2003.

Description

Practices and procedures to prevent or reduce the discharge of pollutants from construction site wastes to the drainage system or adjacent water bodies.

Applications

Construction projects generating non-hazardous solid wastes from construction and demolition (C&D) activities. These wastes include C&D wastes, inert fill material, and recycle/reuse material.

C&D wastes include materials originating from the demolition of roads, buildings, or other structures. Materials generated from these activities include concrete, brick, bituminous concrete, wood, masonry, composition roofing, roofing paper, steel, plaster, and minor amounts of metals.

Inert fill materials are wastes that are not contaminated with hazardous materials such as asbestos or lead-based paint. Inert fill materials do not decompose or produce leachate or other products harmful to the environment. Inert fill materials include earth, soil, rock, cured asphalt, brick, and clean concrete (no exposed steel-reinforcing rod) with no dimension greater than eight inches.

Recycle/reuse materials include but are not limited to: asphalt pavement, cardboard, concrete aggregate (no LBP, asbestos-free), electronic equipment, excavated rock, soil (uncontaminated), Freon from appliances, glass, green waste, metals, ferrous/non-ferrous, used tires, wood and lumbers, furniture, etc.

Installation and Implementation Requirements

- Separate contaminated clean up materials from C&D wastes. Contamination may be from hazardous substances, friable asbestos, waste paint, solvents, sealers, or adhesives.
- Inert fill material shall not contain vegetation, organic material, or other solid waste.
- Inert fill materials shall not be mixed with other C&D waste.

Limitations

None

Inspections and Maintenance

- Inspect construction waste and recycling areas regularly.
- Schedule solid waste collection regularly.
- Schedule recycling activities based on construction/demolition phases.

Sanitary/Septic Waste Management

SM-7

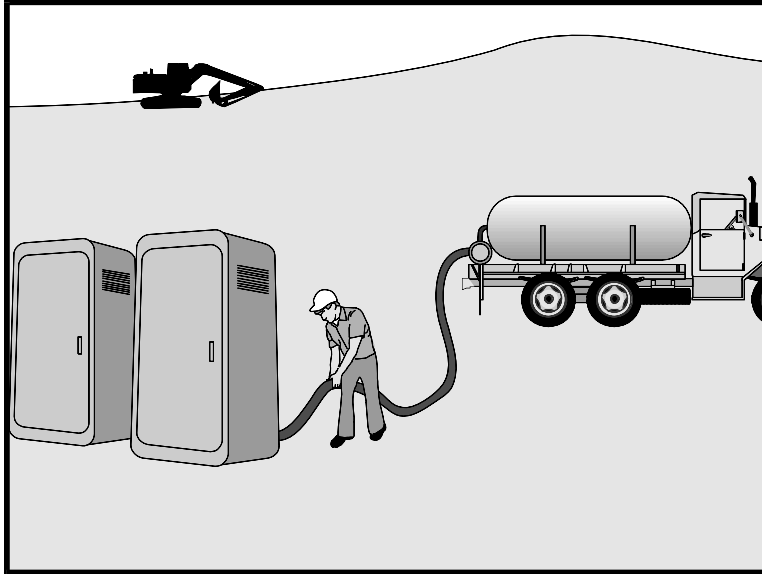

Source: Caltrans Construction Site Best Management Practices Manual, 2003.

Description	Practices and procedures to reduce or prevent the discharge of sanitary wastes from construction sites into the storm drain system or adjacent water bodies.
Applications	Construction sites containing temporary or portable sanitary/septic waste systems.
Installation and Implementation Requirements	<ul style="list-style-type: none">• Locate sanitary facilities in a convenient place away from drainage facilities.• Untreated wastewater shall not be discharged to the ground or buried.• Comply with the State of Hawaii, Department of Health requirements when using an on-site disposal system such as a septic system.• Avoid illicit discharges by properly connecting temporary sanitary facilities to the sanitary sewer system.• Sanitary/septic systems discharging to the sanitary sewer shall comply with the local wastewater treatment plant requirements.• A licensed service provider shall maintain sanitary/septic facilities in good working order.• Schedule regular waste collection by a licensed transporter.
Limitations	None

Sanitary/Septic Waste Management

SM-7

**Inspections and
Maintenance**

- Inspect and maintain facilities regularly.
- Schedule regular waste collection.
- Prevent illicit discharges.

Hazardous Waste Management

SM-9

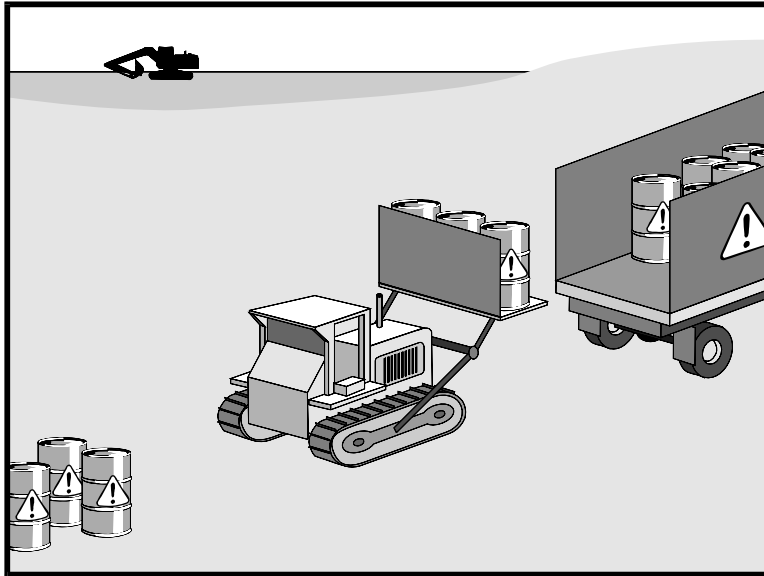

Source: Caltrans Construction Site Best Management Practices Manual, 2003.

Description

Practices and procedures to prevent or reduce the discharge of hazardous waste to the land, storm drain system, or adjacent water bodies.

Applications

Handling procedures on construction sites involving one of the following hazardous wastes:

- Paints and solvents;
- Petroleum products such as oils, fuels, and grease;
- Herbicides;
- Acids for cleaning masonry;
- Concrete curing and repair compounds; and
- Contaminated waste material.

Hazardous waste management shall also be implemented for wastes from existing structures including:

- Sandblasted material such as grit or chips containing lead, cadmium, or chromium-based paints;
- Asbestos; and
- Polychlorinated Biphenyls (PCBs). Older transformers are a common source of PCBs.

Hazardous Waste Management

SM-9

Installation and Implementation Requirements

Recognize potentially hazardous waste by implementing the following:

- Review product label and shipping papers;
- Identify key words such as flammable or ignitable (able to catch fire); carcinogenic (causes cancer); toxic or poisonous (injures or harms people or animals); and hazardous, danger, caustic or corrosive (burns through chemical action). Hawaii Administrative Rules (HAR) Title 11, Chapter 261 includes a list of hazardous waste and criteria;
- Review material safety data sheets (MSDS) from the manufacturer and supplier of the product; and
- Contact DOH, Hazardous Waste Program Office at 586-4226 for additional questions and information.

Material use practices and procedures for hazardous waste management include the following:

- Dispose container only after all of the product has been used;
- Keep the original product label on the container since it includes important safety and disposal information;
- Restrict amount of herbicide prepared to quantity necessary for the current application. Comply with the recommended usage instructions. Do not apply herbicides during or just before a rain event; and
- Remove as much paint from brushes on painted surface. Avoid cleaning or rinsing water-based paint brushes in soil, streets, gutters, storm drains, or streams. Rinse from water-based paints shall be discharged into the sanitary sewer system. Filter and re-use solvents and thinners. Dispose of oil-based paints and residue as a hazardous waste.

Waste recycling and disposal practices and procedures for hazardous waste management include the following:

- Designate areas for collection of hazardous wastes;
- Store hazardous materials and wastes in covered containers;
- Provide secondary containment for hazardous waste containers;
- Keep wastes separate to prevent chemical reactions which make recycling and disposal difficult;
- Recycle useful materials such as oil or water-based paint;
- Avoid disposal of toxic liquid wastes (solvents, used oils, and paints) or chemicals (additives, acids, and curing compounds) in dumpsters allocated for construction debris;
- Schedule periodic waste collection to prevent overflow of containers; and
- Ensure collection, removal, and disposal of hazardous waste complies with regulations.

Hazardous Waste Management

SM-9

Installation and Implementation Requirements (Continued)

Hazardous waste management training shall include the following:

- Awareness of potential dangers from hazardous wastes;
- Identifying hazardous wastes;
- Proper hazardous waste storage and disposal procedures;
- Safety procedures for hazardous wastes;
- Placement of warning signs in areas recently treated with chemicals;
- Use of cleanup materials for spills;

Limitations

Hazardous waste that cannot be reused or recycled shall be disposed of by a licensed hazardous waste hauler.

Inspections and Maintenance

- Regularly inspect hazardous waste collection and storage areas and containers.
- Schedule hazardous waste collection regularly.

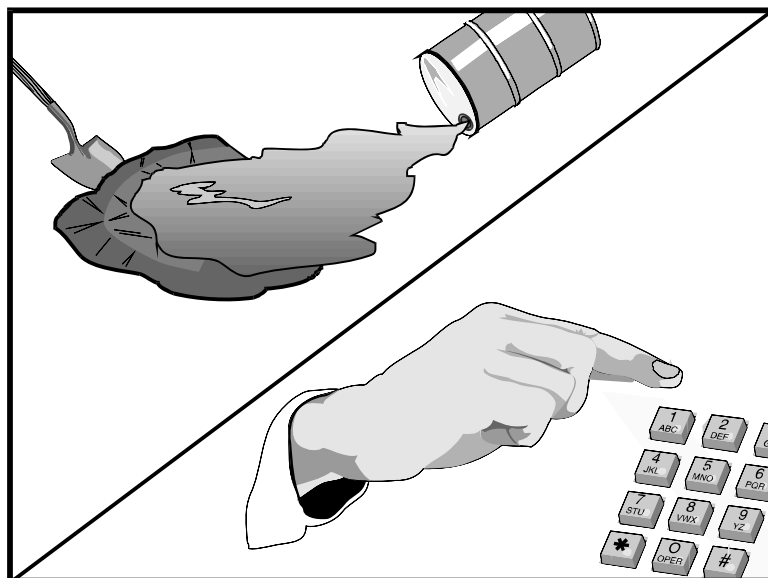

Source: Caltrans Construction Site Best Management Practices Manual, 2003.

Description	Practices and procedures to reduce or prevent leaks or spills which may be discharged into the storm drain system or adjacent water bodies.
Applications	Construction projects involving the storage of chemicals or hazardous substances.
Installation and Implementation Requirements	<p>General Requirements include the following:</p> <ul style="list-style-type: none">• Store hazardous materials and wastes in covered containers and protect containers from vandalism;• Maintain an ample supply of cleanup materials for spills shall be readily accessible;• Train employees on proper spill prevention and cleanup; and• Review spill response requirements at all applicable work sites. <p>Cleanup Requirements include the following:</p> <ul style="list-style-type: none">• Immediately clean up leaks and spills;• Use minimal water to clean up spills on paved surfaces. For small spills, use a rag. For general cleanup, use a damp mop. For larger spills, use absorbent materials. Properly dispose of materials used to clean up hazardous materials; and• Avoid hosing down or burying dry material spills. <p>Reporting includes the following:</p> <ul style="list-style-type: none">• Report significant spills to the U.S. coast Guard, Hawaii State Office of Hazard Evaluation and Emergency Response, and City and

Installation and Implementation Requirements (Continued)

- County of Honolulu agencies, such as the Fire Department and
- Per federal regulations, report significant spills of oil onto an adjoining shoreline or into a water body to the National Response Center at 800-424-8802 (24 hour).

Vehicle and equipment maintenance activities requirements include the following:

- Use a designated area and/or secondary containment for on-site repair or maintenance activities. These areas shall be located away from drainage courses;
- Complete regular inspections of on-site vehicles and equipment, including delivery trucks and employees' vehicles, for leaks. Do not allow vehicles or equipment with leaks on-site;
- Secondary containment devices such as drop cloths and drain pans shall be used to catch leaks or spills while removing or changing fluids from vehicles or equipment;
- Place drip pans or absorbent materials under paving equipment not in use;
- Use absorbent materials on small spills. Avoid hosing down or burying spills. Remove and properly dispose of cleanup materials;
- Immediately transfer used fluids to the appropriate waste or recycling containers. Avoid leaving full drip pans and open containers on-site;
- Drain excess oil from oil filters prior to disposal by placing filter in a funnel over a waste oil recycling drum. Recycle oil filters if this service is available; and
- Store all cracked batteries in a non-leaking secondary container even if the acid appears to have drained out. Handle dropped batteries as cracked batteries until assured it is not leaking.

Vehicle and equipment fueling activities requirements include the following:

- Use designated areas for required on-site fueling. Fueling areas shall be located away from drainage courses;
- Avoid "topping off" of fuel tanks; and
- Use secondary containment devices such as drain pans to catch spills or leaks while fueling.

Limitations

Use of a private spill cleanup company may be necessary.

Inspections and Maintenance

- Update spill prevention and control plans and stock necessary cleanup materials as the chemicals used or stored on-site change.
- Ample supplies of materials for spill control and cleanup shall be located on-site near maintenance and material storage or unloading areas.

Vehicle and Equipment Cleaning

SM-11

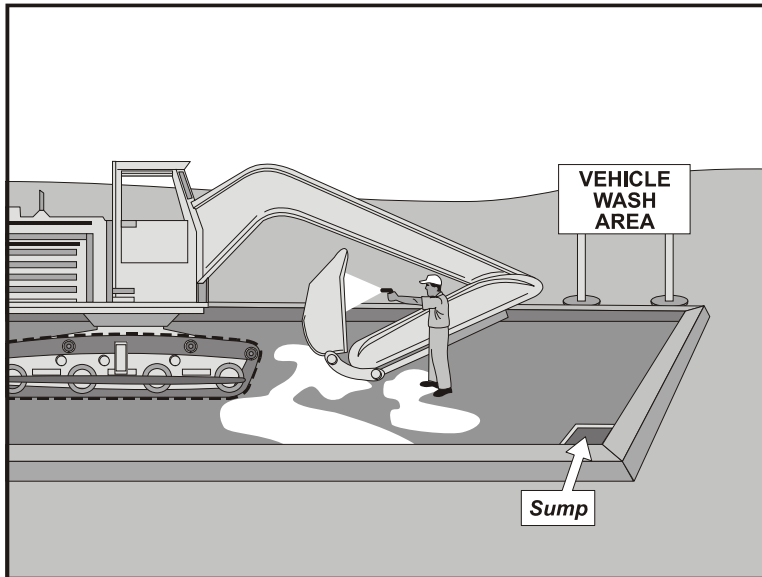

Source: Caltrans Construction Site Best Management Practices Manual, 2003.

Description Practices and procedures to reduce or prevent the discharge of pollutants from vehicle and equipment cleaning activities to storm drain.

Applications Construction or maintenance activities involving cleaning of vehicles and equipment.

- Installation and Implementation Requirements**
- Use off-site vehicle wash racks or commercial washing facilities when practical. Off-site cleaning facilities may be better equipped to properly handle and dispose of wash waters.
 - If on-site cleaning is necessary, designate bermed wash areas for cleaning activities. The wash area may be sloped to facilitate collection of wash water and evaporative drying.
 - Minimize water use to avoid the need for erosion and sediment controls for the wash area.
 - Use phosphate-free, biodegradable soaps.
 - Train employees on pollution prevention measures.
 - Steam cleaning shall not occur in uncontained areas. Significant pollutant concentrations may be generated from steam cleaning.

Limitations Some soaps labeled phosphate-free and/or biodegradable have been shown to be toxic to fish before the soap degrades. Do not discharge wash water directly into streams.

- Inspections and Maintenance**
- Train employees on implementation of revised procedures.
 - Inspect and maintain structural controls.

Vehicle and Equipment Maintenance

SM-12

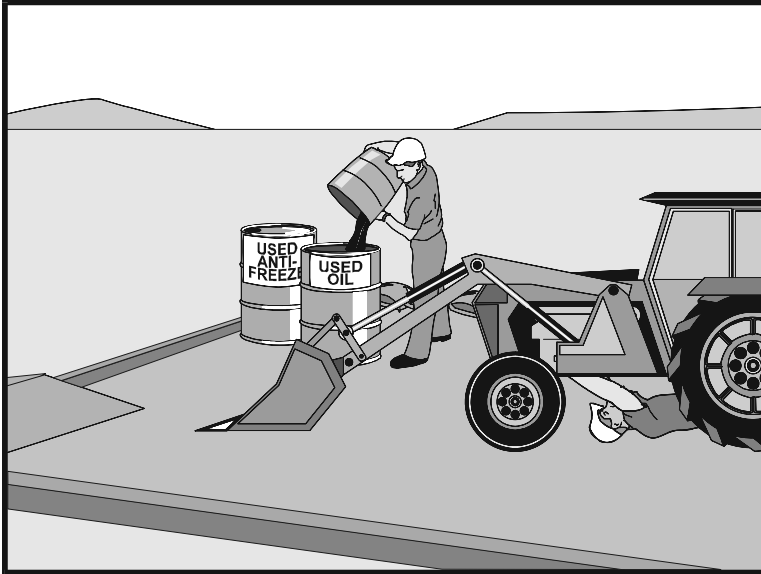

Source: Caltrans Construction Site Best Management Practices Manual, 2003.

Description

Practices and procedures to prevent or reduce the discharge of pollutants from vehicular and equipment maintenance procedures into the storm drain system or adjacent water bodies.

Applications

Construction sites with on-site areas for storage and maintenance of vehicles and equipment.

Installation and Implementation Requirements

- Prevent excessive accumulation of oil and grease by keeping vehicles and equipment clean.
- Use off-site repair and maintenance facilities where practical.
- Designate a maintenance area away from drainage courses to prevent pollutants from entering the drainage system.
- Place drip pans or drop cloths under vehicles and equipment to absorb spills or leaks.
- Provide an ample supply of readily accessible spill cleanup materials.
- Use absorbent materials on small spills. Promptly remove and properly dispose of absorbent materials. Do not hose down or bury small spills.
- On-site vehicles and equipment shall be inspected regularly for leaks and all leaks shall be immediately repaired.
- Incoming vehicles and equipment shall be checked for leaks. Leaking vehicles and equipment shall not be allowed on-site.

Vehicle and Equipment Maintenance

SM-12

**Installation and
Implementation
Requirements
(Continued)**

- Segregate and recycle wastes from vehicle/equipment maintenance activities such as used oil or oil filters, greases, cleaning solutions, antifreeze, automotive batteries, and hydraulic and transmission fluids.
- Properly dispose of wastes generated by vehicle/equipment maintenance activities.
- Provide employee training on proper maintenance and spill cleanup practices and procedures.

Limitations

Off-site maintenance facility may not be easily accessible.

**Inspections and
Maintenance**

- Regularly inspect vehicle and maintenance areas.
- Ample supplies of spill cleanup materials shall be kept on-site.

Vehicle and Equipment Refueling

SM-13

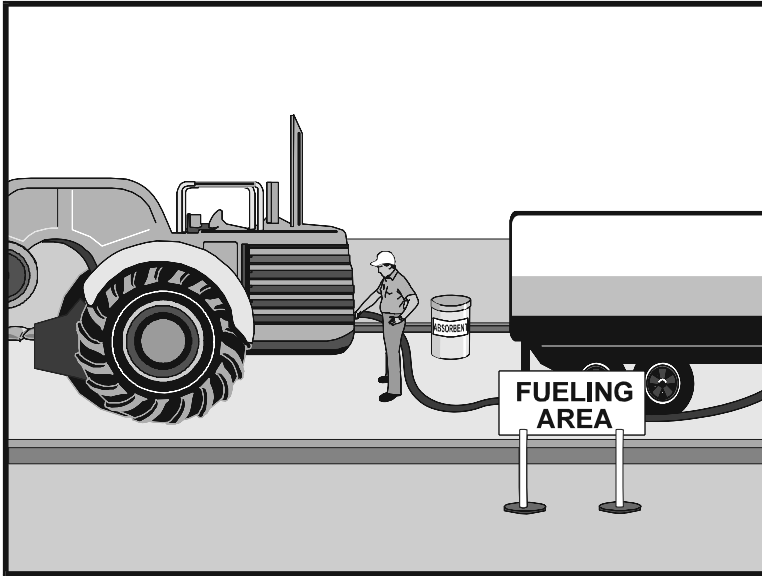

Source: Caltrans Construction Site Best Management Practices Manual, 2003.

Description

Practices and procedures to prevent or reduce the discharge of pollutants to storm water from vehicle and equipment fuel leaks or spills.

Applications

Construction or maintenance activities involving fueling of vehicles or equipment.

Installation and Implementation Requirements

- Comply with Federal and State requirements regarding stationary, above ground storage tanks.
- Use off-site fueling sites when practical. Off-site fueling sites may be better equipped to service and handle spills due to multiple vehicles or pieces of equipment.
- If on-site fueling is necessary, locate designated fuel areas away from drainage courses to prevent contamination of storm water.
- Avoid "topping-off" of fuel tanks.
- Drip pans or drop cloths shall be used to absorb leaks or spills during fueling.
- Absorbent spill cleanup materials shall be available and located in fueling areas.
- Use absorbent materials on small spills instead of hosing down or burying the spill. Promptly remove and properly dispose the absorbent materials.
- Minimize mobile fueling of construction equipment by transporting equipment to designated areas for fueling.
- Train employees on proper fueling and cleanup procedures.

Vehicle and Equipment Refueling

SM-13

Limitations

Off-site fueling of vehicles and equipment may not be practical.

**Inspections and
Maintenance**

- Ample supplies of materials for fuel spill control and cleanup shall be located on-site near fueling areas.
- Regularly inspect fueling areas and storage tanks.

JANUARY				
MONDAY	TUESDAY	WEDNESDAY	THURSDAY	FRIDAY
		1	2 NTP MOBILIZATION	3
			9	10 Grading
6 Install erosion & sediment control measures	7	8 Land clearing		16
		14	15	
12	13			23
			22	

Source: Caltrans Construction Site Best Management Practices Manual, 2003.

Description

Development of a plan that addresses the sequence of construction activities as it relates to the local climate. Scheduling considerations may minimize soil erosion resulting from exposure to wind, rain, runoff, and vehicle tracking.

Applications

Proper scheduling shall be used on all projects.

Installation and Implementation Requirements

- Minimize the area of active construction. Limit is 300,000 square feet.
- Minimize work involving soil disturbing activities during the rainy season.
- Schedule disturbed areas to be stabilized prior to additional grading of other areas.
- Minimize duration of time trenches remain open. Schedule trenching activities to ensure trenches are closed prior to excavating new trenches.
- Implement erosion and sediment control year round.

Limitations

None

Inspections and Maintenance

- Monitor progress of construction activities relative to construction schedule. Implement remedial measures if progress deviates from schedule.
- Revise the schedule as necessary.

Location of Potential Sources of Sediment

SM-15

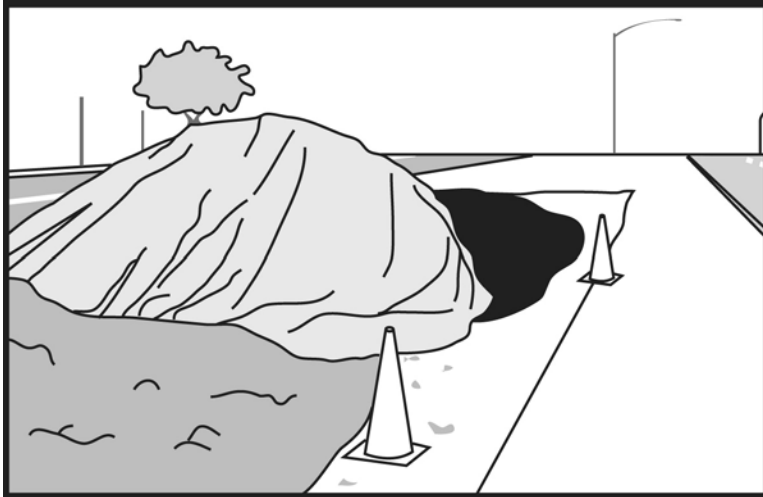

Description	Identify potential sources of sediment to reduce erosion and sediment discharge from construction sites.
Applications	Any potential source of sediment on all projects.
Installation and Implementation Requirements	<ul style="list-style-type: none">• Configure construction site to ensure vegetated areas buffer haul roads and stockpiles. Vegetation provides an effective means of reducing sediment and pollutants discharged off-site.• Place stockpiles away from waterways or low spots.• Direct off-site runoff away from bare ground.• Maintain vegetation in swales and natural drainage ways.• Designate naturally level areas for parking and equipment staging during construction.
Limitations	Additional BMPs such as mulching, planting, and structural controls, including berms, silt fences, and silt basins, shall also be implemented.
Inspections and Maintenance	Inspect construction site periodically and after rain to identify areas requiring installation, repair, or replacement of additional BMPs to cover exposed areas or redirect off-site runoff.

Preservation of Existing Vegetation

SM-16

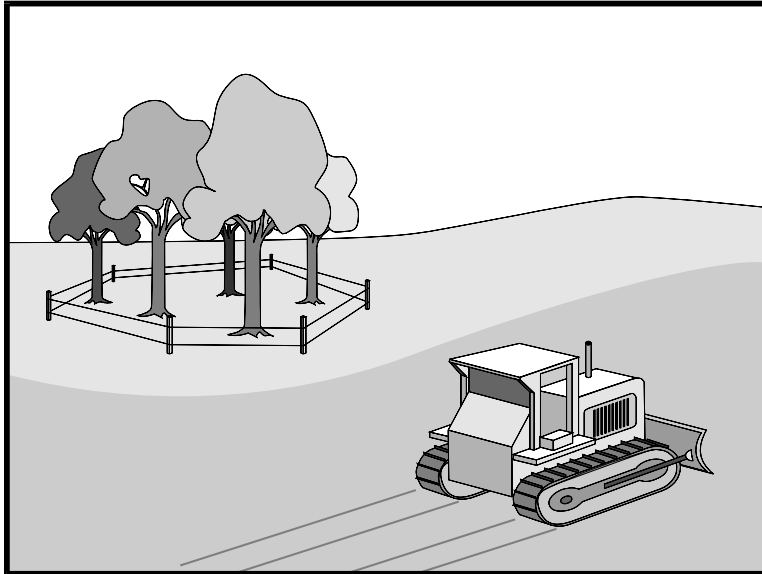

Source: Caltrans Construction Site Best Management Practices Manual, 2003.

Description

Identification of existing vegetation to remain provides erosion and sediment control on a site with future land disturbing activities.

Applications

Preservation of existing vegetation practices apply to the following:

- Areas on-site where no construction activity occurs or will occur at a later date.
- Areas where the existing vegetation should be preserved such as steep slopes, watercourses, and building sites in wooded areas.
- Natural resources or environmental protection areas requiring preservation by local, state, and federal governments such as wetlands and marshes.

Installation and Implementation Requirements

- Incorporate existing vegetation into landscaping plans when possible. Proper care of this vegetation before and after construction is required.
- Consider aesthetic and environmental values, tree/plant health, life span, sun exposure limitations, and space requirements when determining which vegetation to preserve.
- When preparing the landscaping plans, avoid using vegetation which competes with the existing vegetation.
- Establish setback distances defined by devices such as berms, fencing, or signs. Setback distances are based on vegetation species, location, size, and age. The type of construction activity in the vicinity of the vegetation shall also be considered. Construction activities are not permitted within the setback.

Preservation of Existing Vegetation

SM-16

Installation and Implementation Requirements (Continued)

- Protect existing vegetation using one of the following methods:
 - Mark, flag, or fence areas of vegetation to be preserved;
 - Designate limits of root system (tree drip line);
 - Tree wells and retaining walls which are large enough to protect the root system;
 - Limit grading to within one foot of the tree drip lines, if grading under the tree is necessary; and
 - Locate construction traffic routes, spoil piles, etc. away from existing vegetation.

Limitations

- Requires advanced planning and coordination between the owner/developer, contractor, and designer.
- Limited use if final site design does not incorporate existing vegetation.
- Diverse site topography may result in additional expenses to satisfy vegetation preservation and the grading required for the site improvements.

Inspections and Maintenance

Inspect protective measures and immediately repair or replace damaged protection measures.

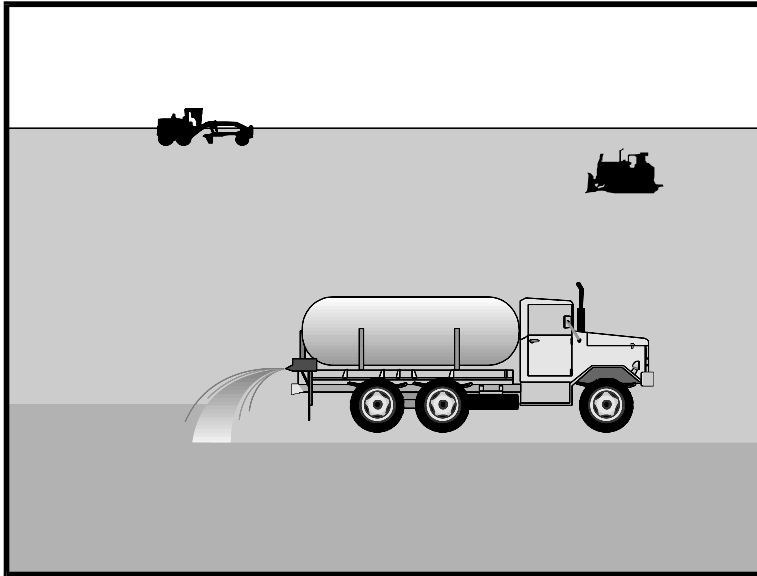

Source: Caltrans Construction Site Best Management Practices Manual, 2003.

Description Application of water and/or dust control measures to minimize erosion due to wind or reduce the amount of dust generated by construction activities.

Applications Dust control shall be used on all exposed soils or any construction activity generating dust. Dust control shall apply to the following:

- Clearing, grubbing, and grading;
- Construction vehicular travel on unpaved roads;
- Drilling and blasting;
- Sediment tracking onto paved roads;
- Soil and debris stockpiles;
- Batch drop from front-end loaders; and
- Unstable soil areas.

Installation and Implementation Requirements

- Minimize exposed areas through the schedule of construction activities.
- Utilize vegetation, mulching, sprinkling, and stone/gravel layering to quickly stabilize exposed soil.
- Identify and stabilize primary entrances/exits prior to commencement of construction.
- Anticipate the prevailing wind direction to minimize the amount of dust generated.
- Do not over-spray water for dust control purposes.
- Direct construction vehicular traffic to stabilized roadways.
- Comply with the 2005 Hawaii Standard Specifications for Road and Bridge in sections 209 and 620.

Limitations

- Daily or more frequent applications of water may be necessary since water is a short-term dust preventative.
- Erosion may result from overwatering.
- Oil may not be used for dust control since the oil may discharge into a drainageway or seep into soil.
- Some dust suppression chemicals may cause soil to be water repellent resulting in increased runoff.

Inspections and Maintenance

Inspect construction site periodically and after rain to identify areas requiring installation, repair, or replacement of additional BMPs to cover bare ground or redirect off-site runoff.