

Construction Best Management Practices Field Manual



**PROTECT
OUR WATER**

MĀLAMA I KA WAI

STATE OF HAWAII DEPARTMENT OF TRANSPORTATION

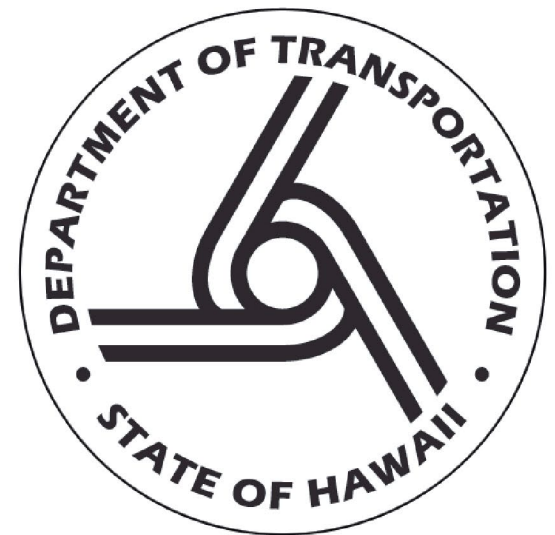

State of Hawaii
Department of Transportation
Highways Division
October 2021



Table of Contents

List of Tables.....	<i>iii</i>
References.....	<i>iv</i>
Acronyms.....	<i>vi</i>
Useful Phone Numbers.....	<i>viii</i>
Introduction.....	<i>x</i>
Chapter 1. Site Management	1
Training	
SM-1 Construction BMP Training.....	2
Material Management	
SM-2 Material Storage and Handling	5
SM-3 Stockpile Management	11
Waste Management	
SM-4 Concrete Wash and Waste Management	15
SM-5 Asphalt Cement Waste Management	23
SM-6 Solid Waste Management	26
SM-7 Sanitary Waste Management	31
SM-8 Contaminated Soil Management	33
SM-9 Hazardous Materials and Waste Management	36
SM-10 Spill Prevention and Control	42
Vehicle and Equipment Management	
SM-11 Vehicle and Equipment Cleaning	49
SM-12 Vehicle and Equipment Maintenance	52
SM-13 Vehicle and Equipment Refueling	55
Site Planning	
SM-14 Scheduling	58
SM-15 Location of Potential Sources of Sediment	61
SM-16 Staging Area	63
General Practices	
SM-17 Preservation of Existing Vegetation	70
SM-18 Dewatering Operations	73
SM-19 Dust Control	76
SM-20 Paving Operations	79
SM-21 Structure Construction and Painting	82
SM-22 Topsoil Management	85



Chapter 2. Erosion Control..... 89

 General Practices

 EC-1 Temporary Stream Crossing 90

 EC-2 Flared Culvert End Sections 96

 EC-3 Run-on Diversion 99

 EC-4 Slope Roughening, Terracing, and Rounding 102

 EC-5 Earth Dikes, Swales, and Ditches 109

 EC-6 Level Spreader 114

 Temporary Concentrated Flow Controls

 EC-7 Slope Drains and Subsurface Drains 117

 EC-8 Outlet Protection and Velocity Dissipation Devices 122

 EC-9 Slope Interceptor or Diversion Ditches/Berms 125

 EC-10 Rip-rap and Gabion Inflow Protection 128

 Soil Stabilization

 EC-11 Geotextiles and Mats 134

 EC-12 Seeding and Planting 141

 EC-13 Hydroseeding 146

 EC-14 Mulching 149

 EC-15 Hydromulching 153

 EC-16 Soil Binders 157

Chapter 3. Sediment Control..... 165

 General Practices

 SC-1 Storm Drain Inlet Protection 166

 SC-2 Vegetated Filter Strips and Buffers 173

 SC-3 Check Dams 179

 Sediment Containment Systems

 SC-4 Sediment Trap 184

 SC-5 Sediment Basin 189

 Sheet Flow BMPs

 SC-6 Compost Filter Berm/Sock 193

 SC-7 Silt Fence or Filter Fabric Fence 200

 SC-8 Sandbag Barrier 205

 SC-9 Brush or Rock Filter 210

 Tracking BMPs

 SC-10 Construction Roads and Parking Area Stabilization 213

 SC-11 Stabilized Construction Entrance/Exit 216



List of Tables

<u>Table</u>	<u>Title</u>	<u>Page</u>
Table 1.	Overview of Storm Water BMPs for Construction Operations.....	<i>xii</i>
Table SM-2.1	Proper storage and handling of materials commonly found on construction sites	6
Table SM-3.1	Common stockpiled materials and example BMPs	11
Table SM-4.1	Commonly used cementitious products.....	16
Table SM-10.1	Useful phone numbers for emergency spill contacts.....	47
Table EC-16.1	Application rates for Guar soil stabilization.....	159
Table EC-16.2	Application rates for copolymers of sodium acrylates, and acrylamides	160
Table EC-16.3	Properties of common soil binders used for erosion control	163
Table SC-10.1	Allowable and not allowable materials used for temporary construction roads and parking areas.....	214



References

City and County of Honolulu, Department of Planning and Permitting, *Rules Relating to Water Quality*, December 2018.

City and County of Honolulu, Department of Environmental Services, *City and County of Honolulu Storm Water Best Management Practice Manual, New and Redevelopment*, July 2014.

City of Knoxville, Engineering Department, Stormwater Engineering Division, *Knoxville BMP Manual*, May, 2003.

City of Reno, *Truckee Meadows Construction Site Best Management Practices Handbook*, February, 2003.

Department of Environmental Services, City and County of Honolulu in cooperation with The General Contractors Association of Hawaii, *City and County of Honolulu, Storm Water Best Management Practice Manual, Construction*, November 2011.

Maryland Department of the Environment, Water Management Administration in association with Soil Conservation Service and State Soil Conservation Committee, *1994 Maryland Standards and Specifications for Soil Erosion and Sediment Control*, 1994.

Prince George's County, Maryland, Department of Environmental Resource Programs and Planning Division, *Low-Impact Development Design Strategies, An Integrated Design Approach*, June, 1999.

State of California, Department of Transportation, *California Storm Water Quality Handbooks, Construction Site Best Management Practices (BMPs) Manual*, 2017.

State of Hawaii, Department of Health, *Evaluation of Environmental Hazards at Sites with Contaminated Soil and Groundwater*, 2017.

State of Hawaii, Department of Health, *Guidance for Soil Stockpile Characterization and Evaluation of Imported and Exported Fill Materials*, 2017.

State of Hawaii, Department of Health, *Hawaii Administrative Rules (HAR), Title 11, Chapter 55, Appendix A, C, F, and G*, 2019.

State of Hawaii, Department of Transportation, *Hawaii Standard Specifications for Road and Bridge Construction, and Special Provisions*, 2005.



State of Hawaii, Department of Transportation, Highways Division, *Statewide Uniform Design Manual for Streets and Highways*, 1980.

State of Hawaii Department of Transportation, Highways Division, Oahu District, *Storm Water Permanent Best Management Practices Manual*, 2015.

State of Hawaii, Department of Transportation, Highways Division, Oahu District, *MS4 NPDES Permit No. HI S000001*, 2020.

State of Hawaii, Department of Transportation, Highways Division, Maui District, *MS4 NPDES Permit No. HII5KE674*, 2016.

United States Department of Transportation, Federal Highway Administration, *The Stormwater Practitioners Guide*, 2018.

Yam, David W. *Slope Face Stabilization for Critical Slope Surfaces*, State of California Department of Transportation District 4 (1978).



Acronyms

BFM	Bonded Fiber Matrix
BMP	Best Management Practice
C&D	Construction and Demolition
CFR	Code of Federal Regulations
CFS	Cubic Feet per Second
CTB	Cement-Treated Base
CWA	Clean Water Act
CWB	State of Hawaii Department of Health, Clean Water Branch
CWRM	State of Hawaii Department of Land and Natural Resources, Commission on Water Resource Management
DLNR	State of Hawaii Department of Land and Natural Resources
DOH	State of Hawaii Department of Health
DOT-HWYS	State of Hawaii Department of Transportation, Highways Division
EAL	Environmental Action Level
EC	Erosion Control
GDI	Grated Drop Inlet
GHS	Globally Harmonized System
H:V	Horizontal to Vertical Slope
HAR	Hawaii Administrative Rules
HDOA	State of Hawaii Department of Agriculture
HDOT	State of Hawaii Department of Transportation
HEER	State of Hawaii Department of Health, Hazard Evaluation and Emergency Response
LBP	Lead-Based Paint
L/SD	Length to Settling Depth
MS4	Municipal Separate Storm Sewer System



NRCS	United States Department of Agriculture, Natural Resource Conservation Service
NGPC	Notice of General Permit Coverage
NPDES	National Pollutant Discharge Elimination System
NRC	U.S. Coast Guard National Response Center
OSHA	Occupational Safety and Health Administration
PCBs	Polychlorinated Biphenyls
PCC	Portland Cement Concrete
PPE	Personal Protective Equipment
RCRA	Resource Conservation and Recovery Act
SC	Sediment Control
SDS	Safety Data Sheet
SHWB	State of Hawaii Department of Health, Solid and Hazardous Waste Branch
SM	Site Management
SPCC	Spill Prevention Control Countermeasures
SSBMP	Site-Specific Best Management Practice
SWPPP	Storm Water Pollution Prevention Plan
USACE	United States Army Corps of Engineers



Useful Phone Numbers

State of Hawaii Department of Health

Clean Water Branch (NPDES Effluent Discharge Permit)	808-586-4309
Hawaii State Hospital (Clean Water Branch, non-business hours).....	808-247-2191
Clean Water Branch – Hilo	808-933-0401
Clean Water Branch – Kona	808-322-1967
Clean Water Branch – Kauai	808-241-3322
Clean Water Branch – Maui	808-873-3556
Solid and Hazardous Waste Branch (construction and demolition waste).....	808-586-4226
Hazard Evaluation and Emergency Response Office (business hours)	808-586-4249
Hazard Evaluation and Emergency Response Office (non-business hours)	808-236-8200

State of Hawaii Department of Land and Natural Resources

Commission on Water Resource Management (Stream Channel Alteration Permits)	808-587-0214
Dam Safety.....	808-587-0268

State of Hawaii Agencies

State of Hawaii Department of Transportation.....	808-587-2150
State of Hawaii Department of Labor & Industrial Relations, Hawaii Occupational Safety and Health Administration	808-586-9116
Hawaii National Guard	808-733-4228

City and County of Honolulu

Honolulu Fire Department, Honolulu Police Department	911
Honolulu Local Emergency Planning Committee	808-723-8960
Grading, Grubbing, or Stockpiling Permits	808-768-8217
Grading Plan Review/Approval Process.....	808-768-8108
Effluent Discharge Permit to Storm Drains-Construction Dewatering.....	808-768-3242
Effluent Discharge Permit to Storm Drains-Hydrotesting.....	808-768-3243
Industrial Discharges to Sanitary Sewer System.....	808-768-3262 or 808-768-3263
Environmental Concern Line	808-768-3300



County of Hawaii

East Hawaii Grading, Grubbing, and Stockpiling/Right-of-Way Permits.....	808-961-8327
West Hawaii Grading, Grubbing, and Stockpiling/Right-of-Way Permits	808-323-4850

County of Kauai

Department of Public Works, Engineering Division – Design and Permitting	808-241-4883
Department of Public Works, Road Construction and Maintenance Division.....	808-241-4847
Department of Public Works, Wastewater Management Division.....	808-241-4082

County of Maui

Grading and Grubbing Permit.....	808-270-7242
Wastewater Permits	808-270-7425
Work on County Highway.....	808-270-7242
Environmental Concern Line	808-270-7869

Federal Agencies

National Resources Conservation Service, Pacific Islands Area	808-600-2911
U.S. Army Corps of Engineers, Regulatory Branch (permits)	808-835-4303
U.S. Coast Guard	808-842-2970
U.S. Coast Guard, National Response Center.....	800-424-8802
U.S. Environmental Protection Agency, Pacific Islands Contact Office.....	808-541-2710



Introduction

The purpose of this manual is to provide guidance on best management practices (BMPs) installation and maintenance procedures for construction activities. Implementation of these BMPs is intended to prevent or reduce the discharge of pollutants to the State of Hawaii, Department of Transportation (HDOT) municipal separate storm sewer system (MS4) and storm drainage systems, including surface waters thereby protecting state waters from pollutant discharges. The BMPs contained in this manual do not constitute an exhaustive list of BMPs.

This manual is intended for use by HDOT Highways staff involved in public and private construction projects and consultants or contractors involved in projects which require work within HDOT Highways rights-of-way or projects which connect or discharge to HDOT Highways MS4. Users must comply with any requirements of the *2005 Hawaii Standard Specifications for Road and Bridge Construction* and Special Provisions, as well as Hawaii Administrative Rules (HAR) Title 11, Chapter 55. The BMPs included in this manual focus on the areas of site management, erosion control, and sediment control. Site Management (SM) BMPs include preventative measures implemented during the planning or construction stage of a project to control potential pollutants at their source. Erosion Control (EC) BMPs are devices installed or constructed by the contractor on disturbed soil to protect the ground surface from erosion due to wind, rain, or runoff. Sediment Control (SC) BMPs are measures to intercept and detain sediment-laden runoff prior to discharge off-site or to the storm sewer system. These devices detain runoff to promote infiltration and/or sedimentation.

Each BMP measure provided in this manual consists of the following:

- Description
- Applications
- Installation and Implementation Requirements
- Considerations
- What to Inspect
- Maintenance

The 2 symbols shown below are used throughout the *Construction BMP Field Manual* to identify good and bad examples of BMPs. The green check mark used alongside a BMP photo denotes an example of a properly installed and maintained BMP. The red "x" used alongside a BMP photo denotes an example of an improperly installed or maintained BMP.





BMP selection shall be determined by an evaluation of the existing conditions and requirements of the project area. Table 1 (shown on the next page) lists commonly used BMPs for various construction operations. The list of BMPs is not meant to be exhaustive. The Table is intended to help with the identification of BMPs that would be appropriate for specific scenarios encountered on a construction site. Continued inspections and maintenance of BMPs are essential to maximizing the effectiveness of the device, application, or procedure.

BMPs must be inspected in accordance with the project Storm Water Pollution Prevention Plan (SWPPP), project permit, and/or HAR Title 11, Chapter 55, whichever is more stringent.

The SWPPP Review Checklist for HDOT Contract Projects, Construction BMP Checklist, and Site-Specific Best Management Practices (SSBMP) Plan/SWPPP Review Checklist are used to facilitate the development and/or review of site-specific BMP plans, depending on the island that construction activities are occurring on and the type of project (private or public). The SWPPP Review Checklist for HDOT Contract Projects and Construction BMP Checklist is provided at website – www.stormwaterhawaii.com. The SSBMP Plan/SWPPP Review Checklist is provided at – website www.stormwatermaui.com.

Disclaimer

The information presented in this *Construction BMP Field Manual* was taken from available and most recent sources deemed to be representative of the BMP and designs for storm water runoff control measures. This manual is prepared as a reference guideline, however, due to site-specific conditions, the selection of the BMPs must be used in conjunction with best professional judgment and sound engineering principles to assure proper function and performance of the BMPs contained herein. The author does not guarantee the accuracy or completeness of this document and will not assume any liability or responsibility for the use of, or for any damages resulting from the use of any information contained herein. The detail and the wording in this manual will not necessarily result in compliance with National Pollutant Discharge Elimination System (NPDES) Permit requirements or state requirements specific to the user's site. Application of any BMPs must comply with manufacturing specifications and any federal, state, and local requirements. In case of conflict between the conditions stated, the more stringent conditions shall apply.



Table 1. Overview of Storm Water BMPs for Construction Operations

Construction Operation	BMP Category	BMPs	BMP Reference
Mobilization	Sediment Control	Street Sweeping	SC-11
	Tracking Control	Stabilized Construction Entrance/Exit	SC-11
		Stabilized Construction Roadway	SC-10
		Entrance/Outlet Tire Wash	SC-11
	Waste Management and Materials Pollution Control	Material Delivery and Storage	SM-2
		Material Use	SM-2
		Spill Prevention and Control	SM-10
		Solid Waste Management	SM-6
		Hazardous Waste Management	SM-9
		Sanitary Waste Management	SM-7
Clearing/Grubbing	Soil Stabilization	Scheduling	SM-14
		Preservation of Existing Vegetation	SM-17
		Hydraulic Mulch	EC-13, EC-15
		Hydroseeding	EC-13
		Soil Binders	EC-16
		Straw Mulch	EC-14
		Geotextiles, Plastic Covers & Erosion Control Blankets/Mats	EC-11
		Wood Mulching	EC-14
		Earth Dikes/Drainage Swales & Lined Ditches	EC-5
		Outlet Protection/Velocity Dissipation Devices	EC-8
	Slope Drains/Subsurface Drains	EC-7	
	Sediment Control	Silt Fence	SC-7
		Desilting Basin	SC-5
		Sediment Trap/Filter Bags	SC-4
		Check Dam	SC-3
		Compost Filter Socks	SC-6
		Gravel Bag Berm	SC-9
		Street Sweeping	SC-11
		Sandbag Barrier	SC-8
	Storm Drain Inlet Protection	SC-1	
Wind Erosion Control	Dust Control	SM-19	



Table 1. Overview of Storm Water BMPs for Construction Operations (continued)

Construction Operation	BMP Category	BMPs	BMP Reference
Clearing/ Grubbing <i>(continued)</i>	Non-Storm Water Management	Vehicle and Equipment Cleaning	SM-11
		Vehicle and Equipment Maintenance	SM-12
		Vehicle and Equipment Refueling	SM-13
	Waste Management and Materials Pollution Control	Stockpile Management	SM-3
		Solid Waste Management	SM-6
Earthwork	Soil Stabilization	Contaminated Waste Management	SM-8
		Scheduling	SM-14
		Preservation of Existing Vegetation	SM-17
		Hydraulic Mulch	EC-13, EC-15
		Hydroseeding	EC-13
		Soil Binders	EC-16
		Straw Mulch	EC-14
		Geotextiles, Plastic Covers & Erosion Control Blankets/Mats	EC-11
		Wood Mulching	EC-14
		Earth Dikes/Drainage Swales & Lined Ditches	EC-5
	Sediment Control	Outlet Protection/Velocity Dissipation Devices	EC-8
		Slope Drains/Subsurface Drains	EC-7
		Silt Fence	SC-7
		Desilting Basin	SC-5
		Sediment Trap/Filter Bags	SC-4
		Check Dam	SC-3
		Compost Filter Socks	SC-6
		Gravel Bag Berm	SC-9
	Tracking Control	Street Sweeping	SC-11
		Sandbag Barrier	SC-8
Wind Erosion Control	Storm Drain Inlet Protection	SC-1	
	Stabilized Construction Entrance/Exit	SC-11	
	Dust Control	SM-19	



Table 1. Overview of Storm Water BMPs for Construction Operations (continued)

Construction Operation	BMP Category	BMPs	BMP Reference
Earthwork <i>(continued)</i>	Non-Storm Water Management	Temporary Stream Crossing	EC-1
		Vehicle and Equipment Cleaning	SM-11
		Vehicle and Equipment Maintenance	SM-12
		Vehicle and Equipment Refueling	SM-13
	Waste Management and Materials Pollution Control	Contaminated Soil Management	SM-8
Portland Cement Concrete and Asphalt/Concrete Operations	Sediment Control	Street Sweeping	SC-11
	Tracking Control	Stabilized Construction Entrance/Exit	SC-11
	Non-Storm Water Management	Paving and Grinding Operations	SM-20
	Waste Management and Materials Pollution Control	Material Delivery and Storage	SM-2
		Material Use	SM-2
		Stockpile Management	SM-3
		Solid Waste Management	SM-6
			Concrete Waste Management
Drainage Work	Sediment Control	Desilting Basin	SC-5
		Sediment Trap/Filter Bags	SC-4
		Check Dam	SC-3
		Storm Drain Inlet Protection	SC-1
	Soil Stabilization	Earth Dikes/Drainage Swales & Lined Ditches	EC-5
		Outlet Protection/Velocity Dissipation Devices	EC-8
Dewatering Operations	Non-Storm Water Management	Dewatering Operations	SM-18
Bridge Construction	Non-Storm Water Management	Paving and Grinding Operations	SM-20
		Temporary Stream Crossing	EC-1
		Vehicle and Equipment Cleaning	SM-11
		Vehicle and Equipment Maintenance	SM-13



Table 1. Overview of Storm Water BMPs for Construction Operations (continued)

Construction Operation	BMP Category	BMPs	BMP Reference
Bridge Construction (continued)	Waste Management and Materials Pollution Control	Material Delivery and Storage	SM-2
		Material Use	SM-2
		Stockpile Management	SM-3
		Spill Prevention and Control	SM-10
		Solid Waste Management	SM-6
		Hazardous Waste Management	SM-9
	Non-Storm Water Control	Concrete Waste Management	SM-4
		Paving and Grinding Operations	SM-20
Roadway Construction	Waste Management and Materials Pollution Control	Temporary Stream Crossing	EC-1
		Material Delivery and Storage	SM-2
		Material Use	SM-2
		Stockpile Management	SM-3
		Solid Waste Management	SM-6
		Hazardous Waste Management	SM-9
Mobile Operations	Sediment Control	Concrete Waste Management	SM-4
		Street Sweeping	SC-11
	Tracking Control	Storm Drain Inlet Protection	SC-1
		Stabilized Construction Entrance/Exit	SC-11
	Non-Storm Water Control	Vehicle and Equipment Cleaning	SM-11
		Vehicle and Equipment Maintenance	SM-12
		Vehicle and Equipment Refueling	SM-13
	Waste Management and Materials Pollution Control	Material Delivery and Storage	SM-2
		Material Use	SM-2
		Stockpile Management	SM-3
		Solid Waste Management	SM-6
		Hazardous Waste Management	SM-9
		Concrete Waste Management	SM-4
Trenching Operations	Sediment Control	Street Sweeping	SC-11
		Storm Drain Inlet Protection	SC-1
	Waste Management and Materials Pollution Control	Stockpile Management	SM-3



Table 1. Overview of Storm Water BMPs for Construction Operations (continued)

Construction Operation	BMP Category	BMPs	BMP Reference
Erosion Control, Highway Planting, and Landscaping	Soil Stabilization	Scheduling	SM-14
		Preservation of Existing Vegetation	SM-17
		Hydraulic Mulch	EC-13, EC-15
		Hydroseeding	EC-13
		Soil Binders	EC-16
		Straw Mulch	EC-14
		Geotextiles, Plastic Covers & Erosion Control Blankets/Mats	EC-11
		Wood Mulching	EC-14
		Earth Dikes/Drainage Swales & Lined Ditches	EC-5
		Outlet Protection/Velocity Dissipation Devices	EC-8
	Sediment Control	Silt Fence	SC-7
		Street Sweeping	SC-11
		Sandbag Barrier	SC-8
		Storm Drain Inlet Protection	SC-1
	Wind Erosion Control	Dust Control	SM-19
	Non-Storm Water Control	Vehicle and Equipment Cleaning	SM-11
	Waste Management and Materials Pollution Control	Material Delivery and Storage	SM-2
		Material Use	SM-2



CHAPTER 1. SITE MANAGEMENT

Site Management (SM) BMPs are preventative measures implemented during the planning and/or construction stage of the project, which control potential pollutants at their source through the use of good housekeeping practices.

In this chapter:

- Training
- Material Management
- Waste Management
- Vehicle and Equipment Management
- Site Planning
- General Practices



Description

Training programs that address the proper installation and maintenance of construction best management practices (BMPs), along with State of Hawaii Department of Transportation, Highways Division's (DOT-HWYS) policies, rules, and procedures regarding construction storm water.

TRAINING OBJECTIVES

Provide the necessary information for personnel to identify potential pollutant sources on DOT-HWYS construction projects and implement practicable solutions.

SEE ALSO

- MS4 NPDES Permit No. HI S000001 (Oahu District)
- MS4 NPDES Permit No. HI15KE674 (Maui District)
- Hawaii Administrative Rules, Title 11, Chapter 55, and all appendices as applicable
- *2005 Hawaii Standard Specifications for Road and Bridge Construction*, Standard Specifications & Special Provisions Section 209
- *City & County of Honolulu Rules Relating to Water Quality*
- Stormwaterhawaii.com
- Stormwatermaui.com
- Youtube.com/user/stormwaterhawaii

Applications

- Personnel with construction storm water responsibilities, including but not limited to designers, construction engineers, construction and maintenance inspectors, plan reviewers, contractors, and sub-contractors are responsible, as applicable, for the following:
 - Designing, installing, maintaining, and/or repairing storm water controls/BMPs (including pollution prevention measures).
 - Applying and storing chemicals.
 - Vehicle/equipment storage, maintenance, and refueling.
 - Conducting inspections.
 - Taking and documenting corrective actions.

Implementation Requirements

- Provide training to DOT-HWYS staff with construction storm water responsibilities, including construction engineers, construction and maintenance inspectors, and plan reviewers. Per MS4 NPDES Permit No. HI S000001, as in effect, training shall be specific to DOT-HWYS activities (including the proper installation and maintenance of accepted BMPs), policies, rules, and procedures.
- Provide relevant educational materials to project applicants, contractors, developers, property owners, and other responsible parties, per MS4 NPDES Permit No. HI S000001, as in effect.
- Provide construction BMP training to contractors and sub-contractors responsible for development of the *Storm Water Pollution Prevention Plan (SWPPP)* and implementation of site-specific BMPs on DOT-HWYS contract construction projects. The contractor shall keep training logs updated and readily available, per *2005 Hawaii Standard Specifications for Road and Bridge Construction*, Standard Specifications & Special Provisions Section 209.03(G), as in effect.
 - Prior to commencement of earth-disturbing activities or pollutant-generating activities, whichever occurs first, at a minimum, personnel must be trained to understand the scope of their job duties, as applicable, as follows:
 - Location of all storm water controls on the site, and how they are to be maintained.



Training should be specific to DOT-HWYS activities, policies, rules, and procedures.

Implementation Requirements *(continued)*

- Proper procedures to follow with respect to the project's pollution prevention requirements.
- When and how to conduct inspections, record applicable findings, and take corrective actions.
- Provide storm water training through field office trainings, product demonstrations, an annual storm water conference, videos, newsletters, and/or field demonstrations.



Product demonstrations provide hands-on training opportunities for BMP installation.

Considerations

- Availability of personnel with storm water responsibilities to attend trainings.
- Motivation and incentive for personnel to learn about erosion and sediment controls.

Training Frequency

- DOT-HWYS provides annual training to staff with construction storm water responsibilities.
- When needed, as new technology, permits, and regulations are created.
- Prior to the commencement of earth-disturbing activities or pollutant-generating activities.
- Provide training to new hires prior to them performing responsibilities related to compliance with applicable permits.
- Site-specific training may be necessary for new construction projects.



Description

Practices and procedures to promote proper handling, storage, and use of construction materials in a manner that minimizes or eliminates storm water pollution, groundwater pollution, soil contamination, and injury to workers or visitors.

Applications

Properly store and handle materials on construction sites based on the general requirements for the materials listed in Table SM-2.1, as applicable:

- Designate a material storage area.
- Locate stored materials away from inlets, concentrated flows, and open waterbodies.
- Provide a cover for stored material.
- Cover with an impermeable material to prevent contact with storm water if materials must be stored in an uncovered area.

SEE ALSO

- Hawaii Administrative Rules, Title 11, Chapter 55, Appendix C (February 9, 2019)
- *2005 Hawaii Standard Specifications for Road and Bridge Construction*, Standard Specifications & Special Provisions Section 209
- 40 CFR 355, Appendix A & B – The List of Extremely Hazardous Substances and Their Threshold Planning Quantities
- 29 CFR Part 1910, Subpart H – Hazardous Materials



Material Storage and Handling

Table SM-2.1 Proper storage and handling of materials commonly found on construction sites

Materials Commonly Found on Construction Sites	Proper Material Storage and Handling
<ul style="list-style-type: none"> • Soil • Fill • Aggregate 	<ul style="list-style-type: none"> • Designate a material storage area. • Locate stored materials away from inlets, concentrated flows and open waterbodies. • Cover stored materials containing fines with an impermeable material to prevent erosion caused by storm water and wind. • Place a compost filter sock, silt fence, or similar sediment barrier device at the base of material stockpiles. • <i>See</i> section SM-3 Stockpile Management.
<ul style="list-style-type: none"> • Soil stabilizers and binders • Fertilizers • Pesticides and herbicides • Detergents • Plasters 	<ul style="list-style-type: none"> • Designate a material storage area. • Locate stored materials away from inlets, concentrated flows and open waterbodies. • Store materials on proper dunnage, pallet, or similar materials to elevate off the ground. • Cover stored materials with an impermeable material to prevent contact with storm water. • Tightly seal container lids when not in use. • Do not apply fertilizer or herbicides during or just before a rain event. • Materials shall be in sealed and properly labeled bags or containers. • All liquid materials shall be stored with an appropriately sized secondary containment.
<ul style="list-style-type: none"> • All metals, including galvanized metal • Rebar 	<ul style="list-style-type: none"> • Rack materials off the ground on proper dunnage, pallet, or similar materials to elevate off the ground. • Cover all metal materials, including galvanized metals and rebar, with an impermeable material to prevent contact with storm water.



Material Storage and Handling

Table SM-2.1 Proper storage and handling of materials commonly found on construction sites (continued)

Materials Commonly Found on Construction Sites	Proper Material Storage and Handling
<ul style="list-style-type: none"> • Asphalt • Asphalt products (i.e., cold patch, tack coat, etc.) • Concrete products (i.e., cold curing compound, form release agents, etc.) 	<ul style="list-style-type: none"> • Designate a material storage area. • Locate stored materials away from inlets, concentrated flows and open waterbodies. • Store materials on proper dunnage, pallet, or similar materials to elevate off the ground. • Cover asphalt and concrete products with an impermeable material to prevent contact with storm water. • Seal in a properly labeled container with a secure lid when not in use. • Provide appropriately sized secondary containment for asphalt and concrete products.
<ul style="list-style-type: none"> • Hazardous materials: acids, lime, glues, paints, solvents, curing compounds, etc. • Petroleum products: fuel, oil, hydraulic fluid, and grease • Creosote-soaked materials 	<ul style="list-style-type: none"> • Designate a material storage area. • Locate stored materials away from concentrated flows, inlets, and open waterbodies. • Cover stored materials with an impermeable material to prevent contact with storm water. • Hazardous materials shall be labeled and stored in the original containers. • Provide appropriately sized secondary containment. • Properly dispose of containers only after all of the product has been used. • <i>See</i> section SM-9 Hazardous Materials and Waste Management.

Installation and Implementation Requirements

Ensure proper material storage and handling practices are implemented on construction sites.

MATERIAL STORAGE

- Materials with the potential to contaminate runoff must be stored under some type of impermeable cover and racked off of the ground to prevent contact with storm water. This BMP will greatly decrease the potential of pollutants originating from storage areas.
- Designate an on-site material storage area. This area shall be located away from concentrated flows, inlets, and open waterbodies.
- Maintain accurate and up-to-date records of materials delivered and stored on-site.
- Minimize on-site inventory.
- Retain a complete set of Safety Data Sheets (SDS) on-site.
- Do not store chemicals, drums, and bagged materials directly on the ground. Metal drums or containers must be covered with 10 mil plastic sheeting to prevent contact with rainwater if stored in an uncovered area.
- Secondary containment must be designed, installed, and operated to prevent any migration of wastes or accumulated liquid out of the containment system to the soil, groundwater, or surface water.
- Secondary containment must be able to retain 100% of the volume of the largest container or 10% of the aggregate total of all the containers being stored within the secondary containment, whichever is greater.
- Hazardous chemicals shall be stored in their original containers with manufacturer's labels and placed in secondary containment.
- All product containers are required to have Globally Harmonized System (GHS) Labels.
- All containers are required to be labeled as to their contents.
- Do not stack more than 2 containers on top of each other to avoid tipping over. Containers may be stacked higher (no more than 3) provided they are secured from tipping over through such methods of shrink wrap or other supportive means. There must be enough room in the containment area to contain any tipped containers.



Secondary containment reduces the risk of spills and leaks from getting into storm water runoff, contaminating soil, and injuring workers or visitors.

Installation and Implementation Requirements *(continued)*

- Fuel containers shall have secondary containment for nozzles/hoses.
- Store soaps, detergents, and solvents under cover or other means to prevent contact with rainwater.
- Materials should not be stored in locations that hinder the effectiveness of other BMPs.
- Do not store materials on erosion and sediment control devices.
- Comply with building and fire code requirements when storing materials.
- Provide appropriate training to all new employees responsible for material storage and handling prior to the commencement of work.



Stacked containers, higher than 2, must be secured from tipping over and under adequate cover.

MATERIAL HANDLING

- Use the appropriate amount of materials necessary to complete the construction activity.
- All personnel shall be trained in accordance with hazardous communication standards. Refer to the Occupational Safety and Health Administration (OSHA), Occupational Safety and Health Standards 29 CFR Section 1910.1200 for more information.
- Minimize the use of hazardous materials. *See* section SM-9 Hazardous Materials and Waste Management for more information.
- Do not remove the original label. Comply with manufacturer's labels, which include product information regarding uses, protective equipment, flammability, ventilation, mixing of chemicals, and proper disposal.
- Use the entire product before disposing of the container in accordance with all federal, state, and local regulations.
- Restrict amount of herbicide prepared to the quantity necessary for the current application. Comply with the recommended usage instructions. Do not apply fertilizers or herbicides during or just before a rain event.
- Comply with building and fire code requirements when storing materials.
- Maintain an ample supply of cleanup materials that are readily accessible for spills.

What to Inspect

- Are storage areas clean, organized, and equipped with an adequate supply of cleanup materials?
- Are secondary containment measures being used and are they appropriately sized?
- Do containers have proper labeling?
- Do containers show signs of corrosion and/or evidence of leaks?
- Are materials properly stored and disposed of?
- Are storage areas located away from drainage structures, concentrated flows and open waterbodies?

Maintenance

- Storage areas shall be clean and well organized.
- Maintain an adequate supply of spill cleanup materials on-site and readily available.
- Any significant residual materials remaining on the ground shall be removed and properly disposed of immediately. If the residual materials contaminate the soil, then the contaminated soil shall also be removed and disposed of properly.
- Maintain covers on any materials that should not come into contact with storm water. All containers must have proper GHS Labels and, if practicable, be in secondary containment.
- Provide periodic training to all employees responsible for material storage and handling.



Galvanized metal and rebar must be racked off the ground and covered with impermeable material.



Description

Stockpile protection measures to reduce the potential for air and water pollution originating from stockpiles of construction materials and spoil piles. Stockpiled materials may include soil, Portland cement concrete (PCC), asphalt concrete, cold mix asphalt, and aggregate. Spoil piles may include materials excavated from a trench, tunnel, shaft or other excavation activity.

Applications

- Provide proper protection of stockpiles on construction sites. Table SM-3.1 provides a list of materials commonly stockpiled on construction sites and examples of BMPs for stockpile protection, depending on what material is being stored and the associated risk it poses.

Table SM-3.1 Common stockpiled materials and example BMPs

Common Stockpile Material	Examples of BMPs
<ul style="list-style-type: none"> • Soil • Topsoil • Excavated material • Imported material • Spoil piles 	<ul style="list-style-type: none"> • Cover stockpile with either: <ul style="list-style-type: none"> – 10 mil plastic sheeting or comparable impermeable material. – soil stabilization measures (i.e., hydromulch, tackifier). • Protect stockpile with a temporary perimeter sediment barrier.

Table SM-3.1 Common stockpiled materials and example BMPs (continued)

Common Stockpile Material	Examples of BMPs
<ul style="list-style-type: none"> • PCC <ul style="list-style-type: none"> – Rubble – Crushed – Hardened – Saw cut 	<ul style="list-style-type: none"> • Cover with 10 mil plastic sheeting or comparable impermeable material (applicable if fines are present). • Protect stockpile with a temporary perimeter sediment barrier.
<ul style="list-style-type: none"> • Asphalt <ul style="list-style-type: none"> – Hot mix asphalt – Asphalt cement (cold mix) – Rubble – Reclaimed asphalt pavement – Cold planed material 	<ul style="list-style-type: none"> • Cover with 10 mil plastic sheeting or comparable impermeable material. • Protect stockpile with a temporary perimeter sediment barrier. • Asphalt (cold mix and hot mix) must be stored on an impervious material.
<ul style="list-style-type: none"> • Aggregate <ul style="list-style-type: none"> – Base – Sub-base 	<ul style="list-style-type: none"> • Cover with 10 mil plastic sheeting or comparable impermeable material. • Protect stockpile with a temporary perimeter sediment barrier.
<ul style="list-style-type: none"> • Treated wood <ul style="list-style-type: none"> – Creosote telephone poles 	<ul style="list-style-type: none"> • Cover with 10 mil plastic sheeting or comparable impermeable material at all times. • Rack materials off the ground or place on top of impermeable material.

Installation and Implementation Requirements

- Locate stockpiles a minimum of 50 feet, or as far as practicable, from concentrated runoff, waterbodies, and inlets. If impracticable, additional precautions should be taken to protect storm drain inlets, open drainage facilities, and waterbodies.
- Place bagged materials on pallets and under cover.
- Provide physical diversion to protect stockpiles from concentrated runoff.
- Cover stockpiles with 10 mil plastic sheeting or comparable impermeable material.
- Cover may be removed while adding to or removing from the stockpile. Replace the cover when not in use.
- Cover should be weighted down to prevent it from blowing off.

Installation and Implementation Requirements *(continued)*

- Geotextile filter fabric is an acceptable cover for mulch stockpiles or other heat producing materials.
- Stockpiles of paving materials must not be placed directly on the ground. Place on 10 mil plastic sheeting or similar impermeable material or dispose of it properly off-site at the end of the day.
- Soil stabilization measures may be used if soil stockpiles will be inactive for an extended amount of time. Hydroseeding, hydromulching, and tackifiers may be accepted as adequate soil stabilization measures. *See* sections EC-13 Hydroseeding, EC-15 Hydromulching, and EC-16 Soil Binders for more information.
- Place silt fence, compost filter socks, or other accepted perimeter controls approximately 1 to 2 feet from the base of the stockpile.
- Stockpiles consisting of aggregate may need to be covered depending on the amount of fines present.
- Stockpiling topsoil for extended periods of time can reduce the biotic benefits of the existing soil. Topsoil stockpiles should be stored for as little time as possible.
- Stockpiles must be covered at the end of each work day and before each anticipated rain event.
- Minimize compaction of soil stockpiles.
- Ensure stockpile heights can be managed and should be no taller than surrounding structures.



Cover stockpiles with 10 mil plastic sheeting or comparable impermeable material and place perimeter controls 1 to 2 feet from the base of the stockpile.

Considerations

- Stockpiles are only applicable for temporary storage of material.
- Perimeter controls for the project limits are not considered stockpile protection.
- Stockpiles cannot be located in any natural buffer area.

What to Inspect

- Are stockpiles completely covered?
- Is perimeter control installed at the base of the stockpile?

What to Inspect *(continued)*

- Are there tears/rips in the stockpile cover?
- Is there evidence of water or wind erosion?
- Are stockpiles located away from concentrated flows, open waterbodies, and inlets?
- Does the stockpiled material have fines and need to be covered?
- Is the stockpile taller than surrounding structures?



Damaged covers and gaps in perimeter protection increase the chance of water or wind erosion from the contents of the stockpile.

Maintenance

- Replace/repair damaged stockpile cover, as needed.
- Ensure the plastic cover is in contact with the ground around the entire pile and properly anchored.
- Replace/repair damaged temporary perimeter sediment barrier.
- Stockpiles removed from the project site shall be disposed of at an approved solid waste permitted facility. Stockpiles shall not be taken to an intermediary site such as a contractor's baseyard (for storage) unless the contractor's baseyard has been issued the appropriate permit from the Department of Health.
- Revegetate any disturbed areas under removed stockpiles, if applicable.
- Reapply temporary stabilization (i.e., hydromulch, tackifier, etc.), if needed.



Cold patch spoil piles or waste asphalt piles must be placed on and covered with impervious material, as well as have full perimeter control around the base of the stockpile.

Concrete Wash and Waste Management



Description

Practices and procedures to manage concrete/cementitious products, washout, and waste to prevent discharges to the ground, the drainage system, or adjacent waterbodies.

Applications

- Projects involving the use of concrete/cementitious products as construction materials.
- Demolition activities generating dust and debris.
- On-site wash areas used for concrete-coated vehicles or equipment.
- Activities such as sawcutting and grinding which result in the formation of slurries containing Portland cement.
- Activities generating fines from sawcutting, grinding, and demolition.

Concrete Wash and Waste Management

Table SM-4.1 Commonly used cementitious products.

Commonly Used Cementitious Products
<ul style="list-style-type: none"> • Concrete • Mortar • Plaster • Stucco • Grout • Cement-Treated Base (CTB)

Installation and Implementation Requirements

- Properly store cement-based materials under cover to prevent contact with storm water. The materials can be classified as waste if improperly stored.
- Designate areas for concrete wash and washout a minimum of 50 feet away, if practicable, from storm drain inlets, open drainage facilities, and waterbodies. If impracticable, per Hawaii Administrative Rules (HAR) Title 11, Chapter 55, Appendix C, 5.1.2.1.1.2, other measures, such as double sediment control (e.g., double perimeter control), must be employed to prevent wash water/waste concrete from reaching the storm drain inlets, open drainage facilities, and waterbodies.
- Avoid mixing excess concrete, if possible. Discard excess concrete in the designated area.
- Disposal of concrete washout via percolation is prohibited. Wash concrete-coated vehicles or equipment in the designated wash area or off-site.
- The designated concrete washout area shall be a temporary pit (below grade), a level bermed area (above grade), or a commercially available system approved to capture concrete wash water.
- The washout should be sufficiently sized so that no overflow can occur due to inadequate sizing or precipitation.
- The washout area shall be lined with an impermeable material (i.e., plastic sheeting, Visqueen, polypropylene, etc.) to prevent seepage of washout into the ground. If plastic is used, it must be a minimum of 10 mil thick. The lining shall be seamless.



Concrete washout area must be lined with an impermeable material. Secondary containment under washout catches any leaks or splashes from the washout area.

Concrete Wash and Waste Management

Installation and Implementation Requirements *(continued)*

- Allow wash water to evaporate or contain the washout in an approved concrete washout system. Provide a minimum freeboard (height above the water mark) of 4 inches for concrete washouts to account for rain events. Washouts must be changed or not used after reaching 75% capacity or 4-inch freeboard, whichever is more stringent.
- If secondary containment is placed under the washout (recommended), it should be bermed under the plastic sheeting to create a secondary pooling area to catch any leaks or splashes.
- Waste concrete shall not be allowed to harden on the bare ground and shall be removed while wet. Materials from the contractor's spill kit can be used to clean up waste concrete.
- Break up and store hardened concrete in the designated area.
- Saw cut slurry shall be removed from the site by vacuuming.
- Provide storm drain inlet protection during sawcutting operations.
- When placing concrete in water environments or tremie pours and drill shafts, any water which is displaced or in contact with wet concrete, mortar, or grout is considered contaminated/concrete impacted.
 - Remove concrete impacted water to a sealed containment area where it cannot contact or percolate into the ground. Holding tanks can be used where water is treated pending release/removal and concrete waste collected for disposal. If a pit is used, it must be sealed against possible leaks to the ground until the water evaporates. Overlapped plastic sheeting in the pit is not permitted.
 - Concrete placement in drill shafts often result in water displacement and requires an over pour of concrete in the shaft. Displaced water must be considered contaminated/concrete impacted and treated as you would above. Any over pour of concrete in contact with the ground must be cleaned up while wet and placed in containment. Plastic sheeting lined pit areas at the drill shaft may also be constructed to catch over pour if adhered to the drill shaft.
- Do not allow concrete liquid wastes onto the ground, into the storm drainage systems, or into waterbodies.



Concrete washouts must be changed or not used after reaching 75% capacity or 4-inch freeboard, whichever is more stringent. Hardened concrete should be removed frequently to avoid overcapacity of washout area.



Concrete Wash and Waste Management

Installation and Implementation Requirements *(continued)*

- Collect and properly dispose of all concrete waste material at a HDOT approved solid waste permitted facility. Dispose of liquid and solid concrete wastes in accordance with solid waste regulations and HDOT policy, as well as other applicable federal, state, and local regulations.
- Provide concrete waste management training for employees and contractors.

Considerations

- Off-site concrete wash areas may be impracticable.
- Locating concrete washout areas a minimum of 50 feet away from drainage systems and open waterbodies may not be practicable.
- May need to allow washout to evaporate.
- Constructing washout areas may not be practicable. Manufactured concrete washout bins may be the only option.
- Rainwater can cause uncovered washout pits and containers to overflow.

What to Inspect

- Has the concrete washout been damaged?
- Is liner a continuous and seamless piece?
- Is the concrete washout area exceeding 75% capacity limits or minimum freeboard of 4 inches?
- Are leaks observed from the designated concrete washout area?
- Is there evidence of concrete waste on ground?
- Are contractors implementing proper concrete waste management measures?

Maintenance

- Regularly remove and dispose of hardened concrete in accordance with solid waste regulations and HDOT policy.
- Remove accumulated concrete washout materials when it reaches 75% capacity or exceeds the minimum 4-inch freeboard requirement.
- Cover temporary concrete washout, when not in use and at the end of the work day, to avoid overflow.

Concrete Wash and Waste Management

Maintenance *(continued)*

- Inspect concrete washout facilities daily and after heavy rains. Replace lining if damaged (i.e., torn, brittle, uv-degraded) before use.
- Immediately clean up concrete waste on bare ground or paved areas before it hardens.
- Vacuum concrete dust and slurry during and immediately after sawcutting activities with proper equipment to prevent/minimize concrete stains. Hosing or washing the area is not allowed.
- Sweep up debris when concrete work is completed for the day.



Clean up concrete waste before it hardens and sweep up debris when concrete work is completed for the day.

Concrete Wash and Waste Management

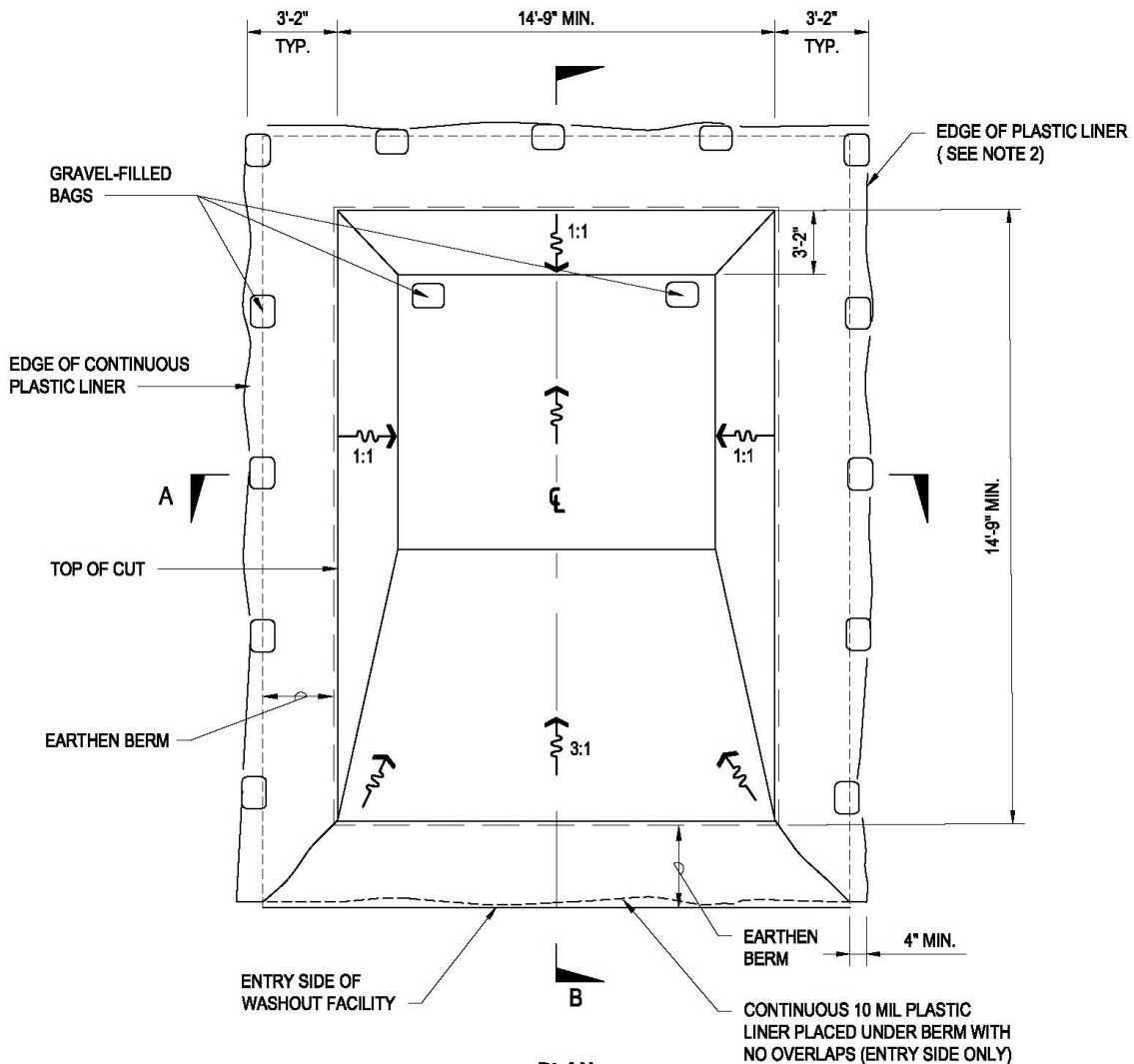

PLAN
NOT TO SCALE

CONCRETE WASHOUT FACILITY (BELOW GRADE)

Concrete Wash and Waste Management

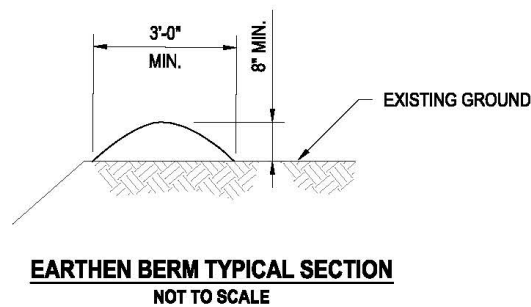
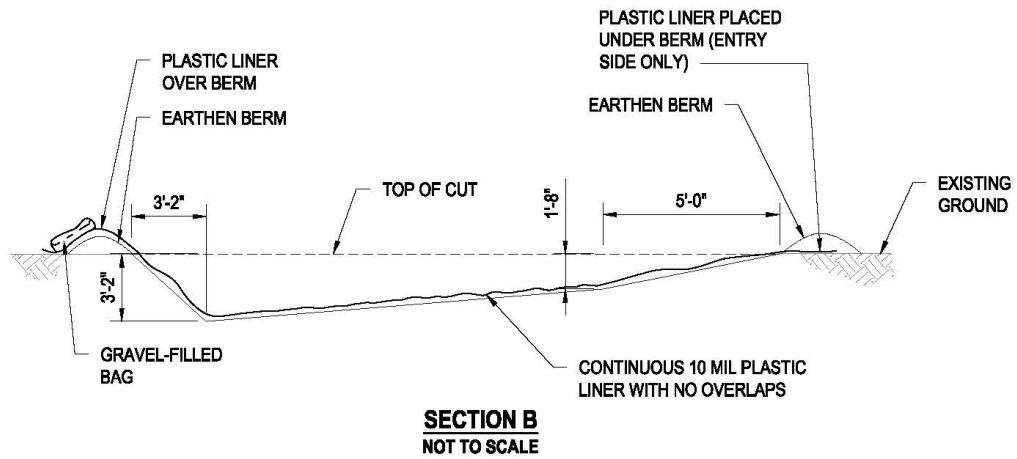
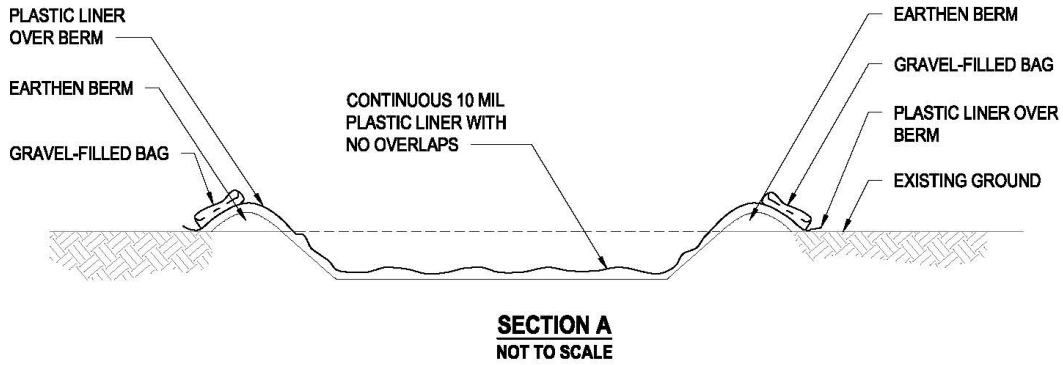

Concrete Wash and Waste Management

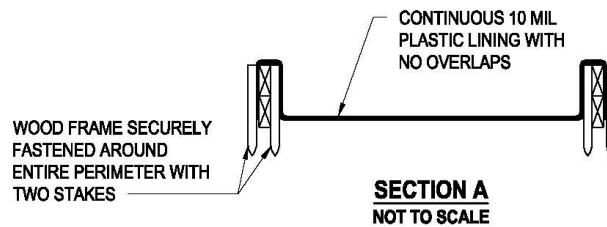
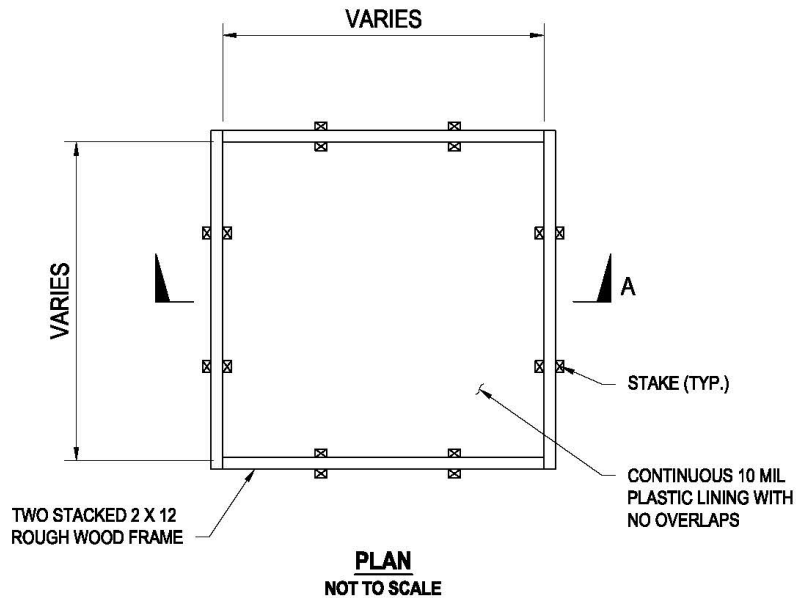

WASH AREA (ABOVE GRADE)

NOTES:

1. ACTUAL LAYOUT DETERMINED IN FIELD.
2. THE SIZE OF THE CONCRETE WASHOUT SHALL BE DETERMINED BY THE ANTICIPATED AMOUNT OF CONCRETE WASTE TO BE STORED.
3. THE PLASTIC LINING MUST BE A CONTINUOUS SHEET WITH NO OVERLAPS.



Description

Practices and procedures to prevent asphalt cement millings and waste from discharging into the drainage system or adjacent waterbodies.

Applications

- Paving operations.
- Milling road and highway surfaces that generate dust and debris.
 - Asphalt cement pavement patching and repair.

Installation and Implementation Requirements

- Ensure all inlets at risk of receiving pollutants are protected with inlet protection during milling operations. *See* section SC-1 Storm Drain Inlet Protection for more information.
- Place temporary cold patch spoil piles or waste asphalt piles on impervious material, cover with impermeable material, and surround with full perimeter control.
- Store paving vehicles and equipment in an approved staging area and fully park on a layer of geotextile filter fabric on top of 10 mil plastic sheeting. *See* section SM-16 Staging Area for more information.



Waste asphalt cannot be stored on bare ground. Ensure that waste asphalt is placed on impervious material.

Installation and Implementation Requirements *(continued)*

- Seed pervious areas disturbed by paving operations within 14 days (7 days if runoff drains to impaired waters) of completing paving to initiate stabilization per Hawaii Administrative Rules (HAR) Title 11, Chapter 55, Appendix C, section 5.2 or per project specifications.
- Clean roads of loose debris by the end of the work day by sweeping or vacuuming.
- Remove waste asphalt from site, including contaminated soil that may be mixed in material, and dispose of properly based on HDOT policies, as well as other applicable federal, state, and local regulations. *See* section SM-8 Contaminated Soil Management for more information.

Considerations

- Staging area may have limited amount of space to store milling and paving vehicles/equipment.
- Contractors may need to implement dust control measures during milling operations.
- Storm water can cause fines from milling to enter into storm drains and open bodies of water.

What to Inspect

- Is there evidence of asphalt waste on bare ground?
- Is the asphalt cement spoil pile properly stored on impermeable material and covered with 10 mil plastic sheeting?
- Has perimeter control been installed at the base of the pile?
- Is milling debris cleaned up at the end of the day?
- Are inlets at risk of receiving pollutants protected?
- Are leaks observed from paving machinery and construction vehicles?
- Does paving equipment have drip protection?



Paving equipment must be stored in an approved staging area and fully parked on a layer of geotextile filter fabric on top of 10 mil plastic sheeting.

Maintenance

- Storage areas shall be clean and well organized.
- Remove any significant residual materials remaining on the ground and properly dispose of immediately. If the residual materials contaminate the soil, then the contaminated soil shall also be removed and disposed of properly.
- Maintain an adequate supply of spill cleanup materials on-site and readily available.
- Maintain covers on any materials that should not come into contact with storm water. All containers must have proper Globally Harmonized System (GHS) Labels, including secondary containers.
- Provide periodic training to all employees responsible for material storage and handling.



Asphalt waste and debris must not enter storm drainage systems or waterbodies.



Description

Practices and procedures to reduce the discharge of pollutants from construction and demolition (C&D) waste from entering the drainage system or adjacent waterbodies.

Applications

- Construction projects generating non-hazardous solid wastes from C&D activities. These wastes include C&D waste, inert fill material, litter and recycle/reuse material.
 - C&D wastes include materials originating from the construction, demolition, and repair of roads, buildings, or other structures.
 - Inert fill materials are defined as earth, soils, rocks, rock-like material, such as cured asphalt, brick, and clean concrete less than 8 inches in diameter, except as specified by a licensed Engineer with no exposed steel reinforced rod. The inert fill material shall not contain vegetation, organic material, or other solid waste. It shall not be contaminated with asbestos or lead-based paint. In addition, inert fill materials do not decompose or produce leachate or products harmful to the environment.

Installation and Implementation Requirements

- Separate contaminated cleanup materials from C&D wastes. Contamination may be from hazardous substances, friable asbestos, waste paint, solvents, sealers, or adhesives.

Installation and Implementation Requirements *(continued)*

- Dispose of waste in designated waste containers.
- Solid waste bins must be watertight and placed away from drainage facilities and open bodies of water.
- Most C&D wastes can be reused or salvaged for recycling. Inert fill materials shall not be mixed with other C&D waste.
- Solid waste is generally any material that leaves a project that is no longer usable on the project. If any material is intended to be characterized as inert fill or soil for reuse, the material shall be tested and determined clean.
- Ensure inert fill material does not contain vegetation, organic material, or other solid waste.
- The Department of Health, Hazard Evaluation and Emergency Response Office (HEER) refers to *Guidance for Soil Stockpile Characterization and Evaluation of Imported and Exported Fill Material*, to define "acceptable fill material" as:
 - Natural materials consisting of soil, clay, sand, volcanic cinder and ash, and rock; or a mixture/combination of such materials.
 - C&D materials exclusive of soil that are known or tested to be free of hazardous substances.
- The fill determination process, defined by HEER, is to determine if proposed fill material meets the definition of acceptable fill material. Options to complete the fill determination process include:
 - An environmental due diligence review of the fill source property that concludes there is no evidence of past releases that could pose an environmental hazard or contain chemical contaminants above applicable State of Hawaii Department of Health (DOH) Tier 1 Environmental Action Levels (EALs).
 - A fill material characterization report that summarizes representative analytical data for the proposed fill material from the fill source operator, fill importer, or fill exporter.
- The contractor shall obtain approval from the Engineer to take any material off-site from an HDOT construction site.
- Provide waste containers of sufficient size and number to contain construction and domestic waste. Dumpsters must be watertight and securely lidded. Roll off containers must be watertight and have a cover to keep rain out and prevent loss of waste during windy conditions.



Waste containers must be covered with an impermeable material at the end of the day and when it is not in use.

Installation and Implementation Requirements *(continued)*

- Waste containers may be covered with 10 mil plastic sheeting/Visqueen, tarpaulin, manufactured lid, or other impermeable material.
- Waste containers shall meet all local and state solid waste management regulations.
- Littering on-site is prohibited.
- Ensure construction waste is collected, removed, and disposed of only at authorized disposal areas. Any site not contiguous with the project site may need a permit to receive solid waste. This includes any site or facility that receives solid waste, landowners who want to accept and process solid waste, and contractors who have to take solid waste to their Baseyard.
- The contractor's supervisory personnel shall be instructed regarding the correct practices for waste disposal. Post notices detailing these practices in the office trailer. The contractor shall ensure that these practices are followed.
- Follow all contract requirements regarding handling and disposal of solid waste.
- Fill out the *Solid Waste Disclosure Form for Construction Sites* at <https://health.hawaii.gov/shwb/sw-permits/>. Inform HDOT of disposal destinations and obtain all permits/approvals relating to stockpiling and disposal of material.
- Do not allow containers to overflow. Plan for waste and recyclable materials to be collected weekly or when containers are two-thirds full, whichever is sooner.
- Minimize production of solid waste materials wherever possible.
- It is highly recommended to reuse C&D waste when possible. For criteria for reuse, refer to DOH Tier 1 EALs for unrestricted land use. Refer to DOH *Evaluation of Environmental Hazards at Sites with Contaminated Soil and Groundwater* for more information on EALs.
- Consideration of soil that exceeds Tier 1 EALs for unrestricted land use, but meets the DOH environmental action levels for commercial use (Refer to DOH *Evaluation of Environmental Hazards at Sites with Contaminated Soil and Groundwater*, Appendix 1, Table I-2) for off-site reuse at such sites must be approved by HEER in consultation with the State of Hawaii Department of Health, Solid and Hazardous Waste Branch (SHWB).
- Notify the Resident/Construction Engineer of any illegal connections, illicit discharges, or illegal dumping not generated by the contractor. Fill out the *Report a Violation Form* at website – <https://www.stormwaterhawaii.com/report-a-violation/> at the time of discovery.



Water is able to get into uncovered waste containers, potentially leading to leaking. Windy conditions may also cause loss of waste from waste containers.

Considerations

- Must sort waste material accordingly.
- Some types of solid waste can easily be washed away by storm water if not properly disposed of.
- The Engineer may reject imported fill from sources known to contain hazardous material.
- The import of fill material from a source that has not been evaluated could inadvertently recontaminate a remediated property, and may be considered illegal dumping. Contaminated fill material can also pose direct exposure hazards to workers and the public.
- Understanding the source of the fill material and the potential for contamination is very important.
- Construction vehicles may be necessary to put C&D waste in the correct bin.
- Construction personnel should not hose out containers on-site. Leave dumpster cleaning to the trash hauling contractor.

What to Inspect

- Are waste containers properly covered?
- Do waste containers exceed two-thirds capacity?
- Is there evidence of leaks or spills around waste containers?
- Is site neat and free of litter?
- Is waste being separated and placed in the appropriate bin?
- Are waste bins located away from drainage facilities, inlets, and open bodies of water?
- Is there evidence of illegal dumping on-site?
- Is trash removed regularly?



Solid waste should be removed regularly so waste containers do not exceed two-thirds capacity.

Maintenance

- Schedule solid waste collection regularly.
- Empty waste containers when they are two-thirds full.
- Schedule recycling activities based on construction/demolition phases.
- Do not allow containers to overflow.



Solid Waste Management

Maintenance (*continued*)

- Repair/replace leaking or damaged dumpsters.
- Clean up site and dispose of waste in designated waste containers by the end of each work day.
- Keep disposal receipts and provide a copy to HDOT to document that the waste is disposed of at the facility permitted on the *Solid Waste Disclosure Form for Construction Sites*.
- Solid waste shall be taken directly from the project site to the facility permitted on the *Solid Waste Disclosure Form for Construction Sites*.



Description

Practices and procedures to reduce or prevent the discharge of sanitary wastes from construction sites into the storm drain system or adjacent waterbodies.

Applications

- Construction sites containing temporary or portable sanitary waste systems.

Installation and Implementation Requirements

- Locate sanitary facilities in a convenient place away from drainage facilities.
- Wastewater shall not be discharged to the ground and open waterbodies, or buried.
- Position sanitary facilities where they are secured and will not be tipped over or knocked down.
- Use of straps, rebar stakes, or similar devices to secure sanitary facilities are required.
- Sanitary systems discharging to the sanitary sewer shall comply with the local wastewater treatment plant requirements.



Stakes can be used to secure sanitary facilities to ensure they will not be tipped over or knocked down.

Installation and Implementation Requirements *(continued)*

- A licensed service provider shall maintain sanitary facilities in good working order.
- Schedule regular waste collection by a licensed transporter at least once a week or as required.
- If a spill occurs, immediately contain and determine if contents have reached an inlet or open waterbody. The area shall be properly disinfected after cleanup of the spill has been completed.
- All spills regardless of size must be reported to the Emergency Spill Response Coordinator and the State of Hawaii Department of Transportation (HDOT) Construction Resident Engineer/Project Engineer/Construction Inspector. *See section SM-10 Spill Prevention and Control for more information.*



Portable toilets must be located away from drainage systems and waterbodies.

What to Inspect

- Are portable toilets secured from tipping over?
- Are contents leaking from septic facility?
- Are portable toilets located away from the drainage systems, concentrated flows and waterbodies?

Maintenance

- Maintain facilities regularly.
- Schedule regular waste collection by a licensed transporter at least once a week or as required.
- Prevent illicit discharges.
- Resecure portable toilets, if needed.



Description

Practices and procedures to identify and prevent the discharge of pollutants from contaminated soil to the drainage system and adjacent waterbodies.

Applications

- Projects in urbanized or industrial areas where previous site usage, undetected spills or leaks, illicit discharges, or underground storage tank leaks may have contributed to soil contamination.

Installation and Implementation Requirements

- Abide by all federal, state, and local regulations when dealing with contaminated soil.
- A site assessment should be conducted prior to ground-disturbing activity to identify contaminated soil or other hazardous pollutants.
- Research records of previous site uses and activities.
- Identify soil discoloration, odors, soil property differences, abandoned underground tanks or pipes, or buried debris to determine possible soil contamination.
- If contaminated soil or other hazardous pollutants are found on-site, stop work in the area immediately and notify the State of Hawaii Department of Health, Hazard Evaluation & Emergency Response (HEER) office (808-586-4249), as well as the Project Engineer.

Installation and Implementation Requirements *(continued)*

- Contaminated soil shall be placed on an impermeable liner or device, such as 20-mil plastic sheeting, surrounded with impermeable lined berms and covered with impermeable sheeting.
- Soil suspected of being contaminated should be isolated from other stockpiles until test results return. If the suspected contaminated soil has evidence of contamination (odor, sheen, color, etc.), then it should be handled and stored as contaminated until testing determines otherwise. Known contaminated soil must be segregated from uncontaminated soil.
- Soil testing is the only option to know if soil is contaminated. Sampling of the soil shall follow DOH guidelines and requirements. Test soil at a certified laboratory if soil is suspected of contamination. Multi Increment testing should be conducted if soil is contaminated with lead because it is commonly unevenly distributed.
- The contractor shall propose the testing protocols for the Engineer’s approval.
- Contaminated soil stockpiles must remain on-site and cannot be transported or stored off-site without prior authorization.
- Temporary stockpiles of contaminated material must have signage designating material as contaminated.
- Identify area to temporarily store contaminated soil away from drainage facilities, waterbodies and conveyance systems.
- Construction vehicles leaving the excavation area must be clean of contaminated soil. All contaminated soil and wash water from vehicle cleaning must be properly contained, collected, and disposed of.
- Contaminated soil disposal options:
 - Re-use on-site (not grossly contaminated)
 - Off-site reuse (Refer to DOH *Guidance for Soil Stockpile Characterization and Evaluation of Imported and Exported Fill Material*)
 - Landfill disposal (check with landfill)



Contaminated material stockpiles must have signage designating material as contaminated.

Considerations

- Dispose of contaminated soils at DOH-permitted facilities. Transfer contaminated soils via DOH-approved transporter.

Considerations *(continued)*

- This manual does not explain environmental laws and regulations. Therefore, it is required to have a licensed contracting firm that is experienced in handling contaminated and hazardous materials when dealing with contaminated soil.
- Site-specific conditions may require the use of additional personal protective equipment (PPE). Gloves and safety glasses must be worn when dealing with contaminated soil.
- A removal action may be conducted either as a stand-alone response action, or as an interim response action to be followed by further removal or remedial action at a later date. In addition, a removal action may result in long-term management of contamination on site. Each of these different types of removal actions has implications for site closure.

What to Inspect

- Are stockpiles of contaminated soil stored on an impermeable liner or device, surrounded by an impermeable lined berm, and completely covered with impermeable material?
- Are the BMP measures installed properly and maintained?
- Has the contaminated soil been properly tested, per DOH guidelines and requirements?
- Is the contaminated soil in contact with non-contaminated bare soil?
- Has the contaminated soil come into contact with rainwater?
- Is the contaminated soil stockpile isolated from other stockpiles?

Maintenance

- Prevent leaks and spills by implementing spill prevention and control practices and procedures. *See* section SM-10 Spill Prevention and Control for more information.
- Repair tears and rips to the impermeable berm and cover to ensure erosion is prevented.
- Damaged perimeter control devices must be repaired/replaced when the device is not functioning as designed.
- Repair/replace barriers that no longer prevent contaminated soil from coming into contact with bare soils.

Hazardous Materials and Waste Management



Description

Practices and procedures to prevent hazardous material and waste from discharging into the storm drain system or adjacent waterbodies.

Applications

Handling and storing procedures on construction sites involving the following hazardous materials and waste:

TYPICAL HAZARDOUS MATERIALS AND WASTES FROM COMMERCIAL CONSTRUCTION AND DEMOLITION (C&D) JOBS

- Oil-based paint, stains, and varnishes
- Acids and bases (e.g., muriatic acid, etc.)
- Ignitable waste (gasoline and diesel)
- Used batteries
- Waste vehicle lubricants (e.g., used motor oil, etc.)
- Latex paint with mercury
- Thinners and painting solvents
- Spent sand blast material from paint removal operations
- Weatherproofing/insulation solvents
- Finishing and flooring adhesives and sealants
- Mechanical/electrical waste
- Absorbent materials used to clean up spills



Hazardous Materials and Waste Management

Applications *(continued)*

- All petroleum-based products
- Concrete curing/repair compounds and related concrete work products
- Contaminated rags
- Waste mercury or acrylic mercury paint
- Non-empty aerosol cans

TYPICAL HAZARDOUS MATERIALS AND WASTE FROM EXISTING STRUCTURES

- Sandblasted material such as grit or chips containing lead, cadmium, or chromium-based paints
- Asbestos
- Polychlorinated Biphenyls (PCBs)
 - Older transformers are a common source of PCBs.

Installation and Implementation Requirements

POTENTIALLY HAZARDOUS WASTE RECOGNITION

- Review product label and shipping papers.
- Identify key words such as flammable or ignitable (able to catch fire); carcinogenic (causes cancer); toxic or poisonous (injures or harms people or animals); and hazardous, danger, caustic or corrosive (burns through chemical action). Hawaii Administrative Rules (HAR) Title 11, Chapter 261 includes a list of hazardous waste and criteria. Review Safety Data Sheets (SDS) from the manufacturer and supplier of the product.

HAZARDOUS MATERIALS HANDLING AND STORAGE

- Hazardous material should remain in the original container. Do not transfer material into another storing device unless it is considered waste.
- Keep the original product label on the container because it includes important safety and disposal information. Keep all SDS at a designated location. Inform all personnel of the location of the SDS.
- Restrict amount of herbicide and fertilizer prepared to the quantity necessary for the current application. Comply with the recommended usage instructions. Do not apply herbicides and fertilizers during or just before a rain event.

Hazardous Materials and Waste Management

Installation and Implementation Requirements *(continued)*

- It is preferred to store hazardous material under a covered facility. If a covered facility is not applicable, materials must be placed in secondary containment and covered with impermeable material to prevent storm water from coming in contact with materials.
- Secondary containment must be able to retain 100% of the volume of the largest container or 10% of the aggregate total of all the containers being stored within the secondary containment, whichever is greater.
- Metal containers shall be covered by an impermeable material so they are not exposed to rainwater, which can cause rusting and potential leaks.
- Secondary containment is required for storing hazardous materials and must be impervious to the materials stored.
- All spills, free products, or storm water captured in a secondary containment shall be immediately removed and properly disposed of.
- Incompatible materials, such as chlorine and ammonia, shall not be stored in the same temporary containment facility.
- Immediately clean up hazardous waste that spills or leaks on the ground. Do not hose down or bury spills.



Hazardous materials stored under a covered facility and in secondary containment prevents storm water from coming into contact with materials.

DISPOSAL OF HAZARDOUS WASTE FROM CONSTRUCTION ACTIVITIES

- It is required to ensure the site has adequate space for hazardous waste storage volume.
- Waste storage areas must be located away from drain inlets, watercourses, and moving vehicles.
- Minimize hazardous waste stored on-site.
- Waste shall not be mixed and drums used for waste shall not be overfilled.
- Label all waste containers with the type of waste being stored and the date of accumulation.

Hazardous Materials and Waste Management

Installation and Implementation Requirements *(continued)*

- Store hazardous waste separate from non-hazardous waste to prevent mixing in case of a spill. Do not mix wastes.
- Remove as much paint from brushes on painted surface. Do not clean or rinse water-based paint brushes in soil, streets, gutters, storm drains, or streams. Rinse from water-based paints shall be discharged into the sanitary sewer system. Filter and reuse solvents and thinners.
- Dispose of oil-based paints and residue as a hazardous waste.
- Place hazardous waste in a sealable container suitable for the material.
- Rainwater that mixes with hazardous waste due to spills or leaks shall be treated as hazardous waste and must be placed in drums.
- Dispose of container only after all of the product has been used in accordance with federal, state, and local regulations.
- Hazardous waste that will not be recycled/reused must be disposed of off-site within 90 days of being generated, or as directed by the Resident/Construction Engineer.
- Maintain an ample supply of cleanup materials that are readily accessible for spills. All employees shall be informed of the location of the cleanup material and trained in their proper use.
- Hazardous waste must not accumulate on the ground.
- A licensed hazardous waste transporter shall dispose of hazardous waste at an authorized disposal facility. For more information regarding licensed transporters, refer to the State of Hawaii Department of Health (DOH) Hazardous Waste Section at website – <http://health.hawaii.gov/shwb/hazwaste/>.



Metal containers must be covered by an impermeable material or under a covered facility to prevent contact with rainwater, which can cause rusting and potential leaks.

WASTE RECYCLING AND DISPOSAL OF HAZARDOUS WASTE

- Designate areas for collection of hazardous wastes.
- Store hazardous materials and wastes in covered containers and label according to applicable Resource Conservation and Recovery Act (RCRA) requirements.
- Provide secondary containment for hazardous waste containers to prevent contact with storm water runoff.
- Keep wastes separate to prevent chemical reactions which make recycling and disposal difficult.
- Recycle useful materials such as oil- or water-based paint.

Hazardous Materials and Waste Management

Installation and Implementation Requirements *(continued)*

- Do not dispose of toxic liquid wastes (solvents, used oils, and paints) or chemicals (additives, acids, and curing compounds) in dumpsters allocated for construction debris.
- Schedule periodic waste collection to prevent overflow of containers.
- Ensure collection, removal, and disposal of hazardous waste complies with regulations.
- Clean up spills immediately. Do not clean spills or surfaces by hosing the area down. Use the appropriate tools in the spill prevention kit to mitigate spills from leaching into the receiving waters or entering a storm drainage system.
- Eliminate the source of the spill to prevent a discharge or a continuation of an ongoing discharge.

Considerations

- Hazardous waste that cannot be reused or recycled shall be disposed of by a licensed hazardous waste hauler.
- Nothing in this section relieves the contractor's responsibility of compliance with federal and state laws.

What to Inspect

- Is hazardous material in secondary containment and covered with an impermeable material?
- Are containers completely empty before being thrown into the waste bin?
- Is plastic cover ripped or torn?
- Are metal containers containing hazardous material rusting or leaking?
- Are original labels on all containers containing hazardous material?
- Are containers completely sealed?
- Is hazardous material in its original container?
- Is there evidence of leaks or spills on ground?
- Is hazardous waste being stored properly and regularly disposed of by a licensed transporter?



Hazardous materials not stored in a covered facility must be placed in secondary containment and under an impermeable cover.



Hazardous Materials and Waste Management

What to Inspect *(continued)*

- Is there an ample supply of cleanup material readily accessible?
- Is hazardous waste being mixed?

Maintenance

- Schedule regular hazardous waste collection.
- Replace/repair secondary containment if there are signs of leaking.
- Replace plastic cover that has rips and tears.
- Immediately clean up spills of hazardous material and dispose of waste properly.
- Maintain areas where hazardous material and waste must be kept clean and well organized.



Description

Proper spill prevention practices and procedures to aid in preventing spills and leaks from discharging into the storm drain system or adjacent waterbodies.

Applications

- Construction projects involving the storage and use of chemicals or hazardous substances.

Installation and Implementation Requirements

- Maintain an ample supply of cleanup materials that are readily accessible for spills.
- Train employees on proper spill prevention and cleanup.
- Review spill response requirements at all applicable work sites.
- Install perimeter control, such as a dike or berm, around areas of concern to prevent spills or leaks from exiting the contained area.
- Eliminate the source of the spill to prevent a discharge or a furtherance of an ongoing discharge.



Spill kits containing cleanup materials can be used to clean up potential leaks and spills.



Spill Prevention and Control

Installation and Implementation Requirements *(continued)*

CLEANUP REQUIREMENTS AND PROCEDURES

- Immediately clean up leaks and spills.
- Use minimal water to clean up spills on paved surfaces. For small spills, use a rag. For general cleanup, use a damp mop. For larger spills, use absorbent materials.
- Properly dispose of materials used to clean up hazardous materials.
- Do not hose down or bury dry material spills.
- Ensure all personnel who are affected by the spill or will be responsible for its cleanup have all appropriate personal protective equipment (PPE).
- If possible, prevent or minimize the amount of the spill that may discharge into the drainage system.

SMALL SPILLS

- Small spills must be taken care of immediately by the first responder.
- Use a rag or any type of absorbent material to soak up the chemical spill. Do not hose down or bury the spill.
- Use a broom or shovel to clean up dry chemical spills.
- Prompt and effective response is the best way to prevent pollutants from coming into contact with storm water.
- Notify the Engineer.

MEDIUM-SIZED SPILLS

- Semi-significant/medium-sized spills can be cleaned up by the first responder with help from construction personnel on-site, but the spill will be too large to soak up with a rag.
- Isolate and contain the chemical spill with the appropriate BMPs and use materials in the spill prevention kit to immediately clean up the spill. Do not let the chemical liquid spread into drainage systems or state waterways.
- Immediately notify the Resident/Construction Engineer.

SIGNIFICANT HAZARDOUS SPILL OCCURRENCE THAT CANNOT BE CLEANED UP/HANDLED BY PERSONNEL ON-SITE

- Immediately notify the Resident/Construction Engineer followed by completing a written report of the incident.
- Immediately stop work in the vicinity of the spill. Remove and keep all non-essential employees away from the spill. Never subject yourself or other personnel to unreasonable risk of illness or injury.



Spill Prevention and Control

Installation and Implementation Requirements *(continued)*

- Call 911 immediately for spills that pose an immediate threat or danger to the public or property.

REPORTING ON-SITE SPILL OCCURENCE

- Where a leak, spill, or other release containing a hazardous substance or oil in an amount equal to or in excess of a reportable quantity established under either 40 CFR Part 110, 40 CFR Part 117, or 40 CFR Part 302 occurs during a 24-hour period, the permittee shall notify:
 - U.S. Coast Guard National Response Center (NRC) at 800-424-8802,
 - The State of Hawaii Department of Health, Clean Water Branch (CWB) during regular business hours,
 - The Hawaii State Hospital Operator during non-business hours at 247-2191, and
 - The CWB via email at cleanwaterbranch@doh.hawaii.gov during non-business hours as soon as the permittee has knowledge of the discharge.
- To report a spill to the State of Hawaii Department of Health Hazard Evaluation and Emergency Response (HEER) office outside of normal business hours, call (808) 236-8200.
- It is expected that HEER is notified via telephone or in-person within 20 minutes of discovery of the release. A follow-up written notification form will also need to be completed and post-marked to HEER no later than 30 days after the initial discovery of a release. (The notification form can be found at <https://health.hawaii.gov/heer/how-to-report-a-release-spill/>).
- Immediately report spills that are 25 gallons or more of petroleum product, such as oil and gasoline, or any spill of any volume that is not contained and remediated within 72 hours to HEER.
- The contractor shall provide to the Engineer, within 7 calendar days of knowledge of the release, the circumstances leading to the release, and the date of the release. The Engineer shall provide this information the CWB.
- For any spills that discharge into the drain system or receiving state waters, immediately notify the CWB. Within 7 calendar days of discovering the occurrence of discharge into the drain system or receiving state waters, submit a discharge report of the following to the CWB:
 - Any follow-up actions taken to review the design, installation, and maintenance of storm water controls, including the dates such actions occurred.
 - A summary of storm water control modifications taken or to be taken, including a schedule of activities necessary to implement changes, and the date the modifications are completed or expected to be completed.

Installation and Implementation Requirements *(continued)*

- Notice of whether *Storm Water Pollution Prevention Plan (SWPPP)* modifications are required as a result of the condition identified or corrective action.

VEHICLE AND EQUIPMENT MAINTENANCE ACTIVITIES

- Use off-site repair and maintenance shops as much as possible. These repair and maintenance shops are better equipped to handle vehicle fluids and spills properly.
- If on-site repair is necessary, use a designated area and/or secondary containment for on-site repair or maintenance activities. These areas shall be located away from drainage courses, inlets, and open waterbodies.
- Conduct regular inspections of on-site vehicles and equipment, including delivery trucks and employee vehicles, for leaks. Do not allow vehicles or equipment with leaks on-site.
- Secondary containment devices such as drop cloths and drain pans shall be used to catch leaks or spills while staging or changing fluids from vehicles or equipment.
- Drip pans can be used to catch potential leaks from idle vehicles and equipment.
- Place drip protection/pads with absorbent and impermeable materials under all vehicles and equipment with the potential to leak/spill when not in use.
- Use absorbent materials on small spills. Do not hose down or bury spills. Remove and properly dispose of cleanup materials.
- Minimize the movement of drums and containers filled with hazardous material.
- Immediately transfer used fluids to the appropriate waste or recycling containers. Avoid leaving drip pans and open containers with hazardous material on-site. Large-diameter funnels must be used to transfer liquids into drums.
- Drain excess oil from oil filters prior to disposal by placing filter in a funnel over a waste oil recycling drum. Recycle oil filters if this service is available.
- Store all cracked batteries in a non-leaking secondary container even if the acid appears to have drained out. Handle dropped batteries as cracked batteries until assured it is not leaking.

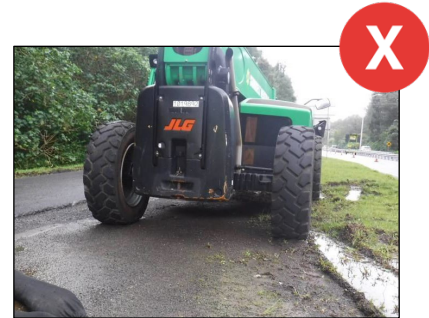

Drip protection or pads with absorbent and impermeable material must be placed under construction vehicles and equipment when not in use.

VEHICLE AND EQUIPMENT FUELING ACTIVITIES

- Use off-site fueling stations as much as possible.
- If on-site fueling is necessary, use designated areas for required on-site fueling. Fueling areas shall be located away from drainage courses, inlets, and waterbodies.

Installation and Implementation Requirements *(continued)*

- Avoid “topping off” of fuel tanks.
- Use secondary containment devices such as drain pans to catch spills or leaks while fueling.

Considerations

- Use of a private spill cleanup company may be necessary.
- This BMP only applies to spills caused on-site by the contractor, sub-contractors, and their vendors.
- Only respond to spills if you can do so safely.

What to Inspect

- Are drip pans and/or absorbent material placed under construction vehicles and equipment?
- Is there an ample amount of spill cleanup material on-site and easily accessible?
- Are spills/leaks evident around construction vehicles, equipment, stored materials, drain inlets or open bodies of water?
- Are there tears/rips in plastic sheeting or geotextile covers?
- Is plastic cover or other impermeable material overlapped and secured (duct tape is applicable)?
- Are perimeter controls in good condition and able to operate properly, in case of a spill?
- Are facilities away from waterbodies and drainage systems?
- Do facilities have sufficient spill containment areas?
- Are facilities located on impervious surfaces?
- Does sufficient containment volume exist?
- Do locations for storing hazardous materials and chemicals exist?
- Are hazardous material drums/containers properly labeled?
- Are hazardous and chemical materials/waste stored in secondary containment?
- Are hazardous and chemical materials/waste covered by an impermeable material?



Cleanup procedures must be followed when leaks from vehicles, equipment, and stored materials are evident.



Spill Prevention and Control

Maintenance

- Update spill prevention and control plans and stock necessary cleanup materials as the chemicals used or stored on-site change.
- Locate an ample supply of materials for spill control and cleanup on-site near maintenance and material storage or unloading areas.
- Replace/repair impermeable material/plastic covers that have rips or tears.
- Realign perimeter control devices, when necessary, to ensure proper function.
- Immediately clean up spills.

Table SM-10.1 Useful phone numbers for emergency spill contacts.

Emergency Spill Contacts	Phone Number
Honolulu Fire Department; Honolulu Police Department	911
State of Hawaii Department of Health, Hazard Evaluation and Emergency Response Office	(808) 586-4249 or (808) 236-8200 during non-business hours
State of Hawaii Department of Health, Clean Water Branch – Oahu	(808) 586-4309 or (808) 247-2191 during non-business hours
State of Hawaii Department of Health, Clean Water Branch – Maui	(808) 873-3556
State of Hawaii Department of Health, Clean Water Branch – Hilo	(808) 933-0401
State of Hawaii Department of Health, Clean Water Branch – Kona	(808) 322-1967
State of Hawaii Department of Health, Clean Water Branch – Kauai	(808) 241-3322
Honolulu Local Emergency Planning Committee	(808) 723-8960
Maui Local Emergency Planning Committee	(808) 870-7404
Hawaii Local Emergency Planning Committee	(808) 936-8181



Spill Prevention and Control

Table SM-10.1 Useful phone numbers for emergency spill contacts (continued)

Emergency Spill Contacts	Phone Number
Kauai Local Emergency Planning Committee	(808) 241-1800
U.S. Coast Guard	(808) 842-2970
Hawaii National Guard	(808) 733-4228
State of Hawaii Department of Transportation, Highways Division, Oahu District	(808) 831-6700
State of Hawaii Department of Transportation, Highways Division, Maui District	(808) 873-3538
State of Hawaii Department of Transportation, Highways Division, Hawaii District	(808) 933-8866
State of Hawaii Department of Transportation, Highways Division, Kauai District	(808) 241-3000
State of Hawaii Department of Health, Solid Waste & Hazardous Waste Branch	(808) 586-4226
U.S. Coast Guard National Response Center	(800) 424-8802 (24 hour)
State of Hawaii Department of Labor & Industrial Relations, Hawaii Occupational Safety and Health Administration	(808) 586-9116



Description

Practices and procedures to prevent the discharge of pollutants from equipment and vehicle cleaning activities from entering the drainage system or adjacent waterbodies.

Applications

- Construction or maintenance activities involving cleaning of vehicles and equipment.

Installation and Implementation Requirements

- Use off-site vehicle wash racks or commercial washing facilities when practical. Off-site cleaning facilities may be better equipped to properly handle and dispose of wash waters.
- If on-site cleaning is necessary, designate a paved surface and bermed wash area for cleaning activities. The wash area may be sloped to facilitate collection of wash water and evaporative drying. Water must be contained in the bermed wash area.
- Use a positive shutoff valve when cleaning vehicles and equipment to minimize water usage.



Use of a designated paved surface and bermed wash area helps prevent the discharge of pollutants from equipment and vehicle cleaning from entering drainage systems and waterbodies.

Installation and Implementation Requirements *(continued)*

- Removal of sediment or soil from vehicles and equipment, except for contaminated media, can be done on pervious areas as long as they are cleaned through dry cleanup measures (e.g., tire sweeping, vacuuming, etc.) only.
- Do not allow wash water to enter the storm drainage system or open waterbodies.
- Minimize the amount of water being used to clean vehicles and equipment.
- Vehicle and equipment cleaning using soaps, solvents, or detergents are only allowed in an impervious area where water can be captured and either treated (i.e., oil/water separator) or disposed of properly (off-site).
- Properly store soaps, detergents, and solvents. *See* section SM-2 Material Storage and Handling for more information.
- Only use phosphate-free, biodegradable soaps.
- Do not discharge wash water directly into the storm drainage system or open waterbodies.
- Minimize water use to avoid the need for erosion and sediment controls for the wash area.
- If vehicles and equipment are cleaned off in the field, ensure waste is collected and disposed of properly.
- Do not store hazardous material in the wash area.
- Cover the wash area when it is not in use to prevent contact with storm water.
- Train employees on pollution prevention measures.
- Do not wash personal vehicles on-site.
- Steam cleaning shall not occur in uncontained areas. Significant pollutant concentrations may be generated from steam cleaning.
- Remove the wash area and stabilize disturbed areas once the project is complete.



Vehicle and equipment cleaning using soaps, solvents, or detergents are only allowed in an impervious area where water will be captured and either treated or disposed of properly.

What to Inspect

- Are pollution prevention controls (i.e., berms, sumps, oil/water separators, etc.) properly functioning?
- Are soaps, detergents, and solvents properly stored?



Vehicle and Equipment Cleaning

What to Inspect *(continued)*

- Are there traces of soap and solvents in pervious wash areas?
- Is there a presence of pollutants (i.e., concrete, oils, etc.) observed in the wash area?
- Are all wash areas located in impervious areas?
- Is wash water being captured?
- Is there evidence of prohibited discharge?

Maintenance

- Any sediment or other potential pollutants removed from vehicles and equipment during cleaning activities should be managed and/or disposed of appropriately.
- Repair/replace pollution prevention controls (i.e., berm, sump, etc.) if not operating per design.
- Wash water containing soaps, detergents, and solvents should be routinely disposed of.



Description

Practices and procedures to prevent or reduce the discharge of pollutants from vehicle and equipment maintenance. When vehicles and equipment need maintenance, the best option is to perform these activities off-site to avoid spills and leaks on-site. If on-site maintenance activities are necessary, they should be conducted in an approved designated area.

Applications

- Construction sites with vehicle and equipment maintenance areas.
- Construction sites where vehicle and equipment are stored when not in use.
- Construction sites where vehicle and equipment are idle, but intermittent use is occurring.

Installation and Implementation Requirements

- Prevent excessive accumulation of oil and grease by keeping vehicles and equipment clean.
- Use off-site repair and maintenance facilities where practical.
- Repair oil and fluid leaks immediately.
- Immediately place a drip pan or drip pad under the vehicle once a leak is observed until repairs can be made.

Installation and Implementation Requirements *(continued)*

- Designate a leveled maintenance area away from drainage courses and inlets to prevent pollutants from entering the drainage system.
- Store vehicles and equipment that need maintenance on a layer of geotextile filter fabric on top of 10 mil plastic sheeting before conducting maintenance activities. Perimeter controls must be placed along the perimeter of the maintenance area and underneath the impermeable material, to create a berm able to contain any possible spills and/or leaks.
- Have an ample supply of readily accessible spill cleanup materials on-site, at all times.
- Use absorbent materials on small spills. Promptly remove and properly dispose of absorbent materials. Do not hose down or bury small spills. *See* section SM-10 Spill Prevention and Control for more information.
- Check vehicles and equipment regularly for leaks. Leaking vehicles and equipment shall not be allowed on-site.
- Keep maintenance areas clean and orderly to minimize oil and grease buildup.
- Segregate and recycle wastes from vehicle/equipment maintenance activities such as used oil, oil filters, greases, hydraulic and transmission fluids, cleaning solutions, antifreeze, and automotive batteries.
- Oil, fuels, fluids and lubricants should be recycled whenever possible. Do not dump on the ground or pour into storm drains.
- Properly dispose of wastes generated by vehicle/equipment maintenance activities.
- Provide employee training on proper maintenance and spill cleanup practices and procedures.



If a leak is observed, immediately place a drip pan or drip pad under the vehicle until repairs can be made.

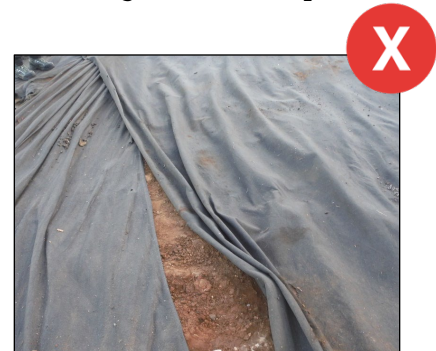

Geotextile filter fabric must have 10 mil plastic sheeting underneath it to contain leaks and spills.

Considerations

- Off-site maintenance facility may not be easily accessible.
- Vehicle and equipment maintenance should only be used when off-site maintenance is impractical.



Vehicle and Equipment Maintenance

What to Inspect

- Are leaks and/or spills coming from vehicles and/or equipment?
- Is there evidence of oil, grease, fluids, lubricants, etc. on the ground?
- Are spill cleanup materials available on-site?
- Are vehicles and equipment properly stored on a layer of geotextile filter fabric on top of 10 mil plastic sheeting?
- Are berms properly aligned along the perimeter of the maintenance area?
- Is the maintenance area on leveled ground away from drainage courses?
- Are maintenance areas kept clean and orderly?
- Are vehicles being taken off-site for maintenance?

Maintenance

- Maintain an adequate supply of spill cleanup materials on-site.
- Remove used oils, antifreeze, grease, lubricants, etc. routinely.
- Do not allow used oils to accumulate on-site.
- Maintain adequate supplies of spill cleanup materials on-site.
- Leaking vehicles and equipment shall be repaired promptly.
- Leaks and spills shall be cleaned up immediately.
- Maintain impermeable material/plastic sheeting, geotextile filter fabric, and perimeter control to ensure proper effectiveness.



Description

Practices and procedures to prevent or reduce the discharge of pollutants to storm water from vehicle and equipment fuel leaks or spills.

Applications

- Construction or maintenance activities involving fueling of vehicles or equipment.

Installation and Implementation Requirements

- Use off-site fueling sites when practical. Off-site fueling sites may be better equipped to service and handle spills due to multiple vehicles or pieces of equipment.
- If on-site fueling is necessary, locate designated fuel areas away from storm water run-on and runoff, and locate fueling areas at least 50 feet, or as far as practicable, from downstream drainage facilities and watercourses to prevent contamination of storm water. If impracticable, consider implementing additional BMPs or secondary containment when fueling.
- Avoid “topping-off” of fuel tanks.
- Drip pans or absorbent pads shall be used to absorb leaks or spills during fueling.



Protect on-site fueling areas with berms and dikes to prevent run-on, runoff, and to contain spills.

Installation and Implementation Requirements *(continued)*

- Fueling must be performed on a leveled area.
- Protect fueling areas with berms and dikes to prevent run-on, runoff, and to contain spills.
- Have absorbent spill cleanup materials located in fueling areas.
- Use absorbent materials on small spills. Do not hose down or bury the spill. Promptly remove and properly dispose the absorbent materials. *See* section SM-10 Spill Prevention and Control for more information.
- Clean up spills or contaminated surfaces immediately, using dry cleanup measures where possible, and eliminate the source of the spill to prevent a discharge or a furtherance of an ongoing discharge. Store hazardous materials and fluids under cover and in secondary containment. *See* section SM-9 Hazardous Materials and Waste Management for more information.
- Minimize mobile fueling of construction equipment by transporting equipment to designated areas for fueling.
- Train employees on proper fueling and cleanup procedures.
- Put fuel pods and hoses in secondary containment to prevent hoses/nozzles from leaking.
- Store diesel fuel, oil, hydraulic fluid, or other petroleum products or other chemicals in watertight containers and provide cover or secondary containment. If container is metal, cover is required.
- Containers shall be properly labeled.
- Comply with federal and state requirements regarding stationary, above ground storage tanks.
- Comply with the Spill Prevention Control Countermeasures (SPCC) requirements in 40 CFR 112 and section 311 of the Clean Water Act (CWA).



There must be drip protection under vehicles and equipment that are being refueled on-site.

What to Inspect

- Is there evidence of fuel spills or leaks on the ground?
- Are any vehicles and/or equipment leaking fuel?
- Are hoses/nozzles in secondary containment?
- Are berms and absorbent pads well-maintained and effective?

What to Inspect *(continued)*

- Is there an ample amount of spill cleanup materials on-site?
- Are hazardous fluids properly stored?

Maintenance

- Keep an ample supply of materials for fuel spill control and cleanup located on-site near fueling areas available at all times.
- Properly dispose of absorbent pads, hazardous material and contaminated soil.



Ensure that drip protection is adequate enough to capture any potential vehicle or equipment leaks.

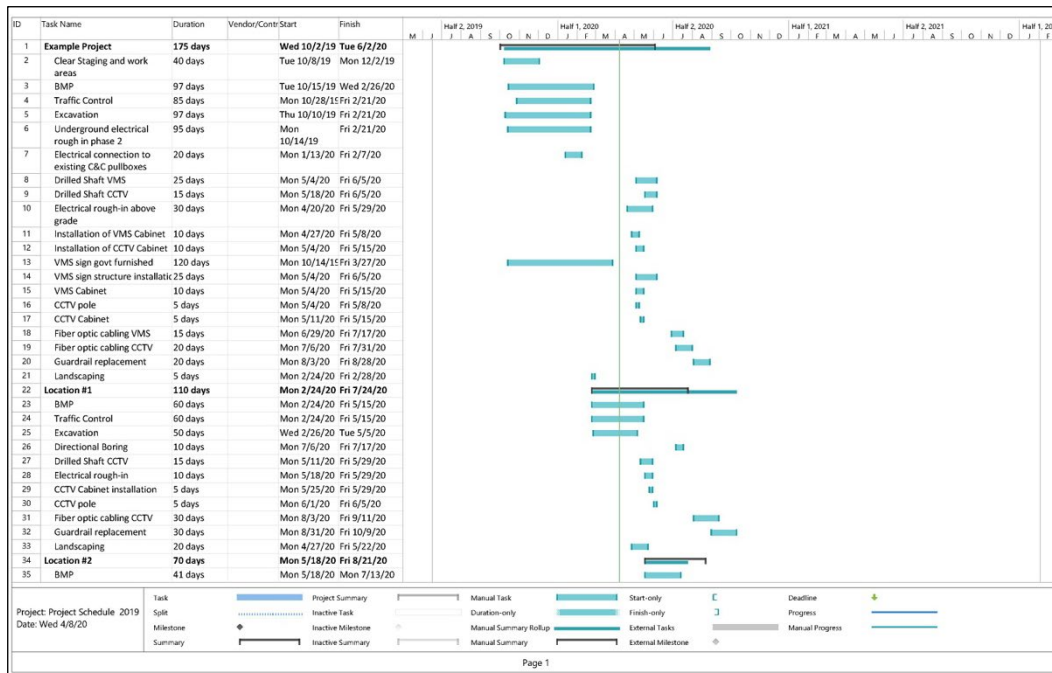

Description

Developing a schedule that includes sequencing of construction activities with the implementation of construction site BMPs to reduce the amount and duration of soil exposed to erosion by wind, rain, runoff, and vehicle tracking as well as ensure construction activities and control practices are performed in accordance with the planned schedule.

Applications

- Proper scheduling shall be used on all projects.

Installation and Implementation Requirements

- The *Storm Water Pollution Prevention Plan (SWPPP)* must include a description of the intended sequence of construction activities, including a schedule of the estimated start dates and the duration of the activity, for the following activities:
 - Installation of storm water control measures, and when they will be operational, including an explanation of the sequence and schedule for installation of storm water control measures.

Installation and Implementation Requirements *(continued)*

- Commencement and duration of earth-disturbing activities, including clearing and grubbing, mass grading, site preparation (i.e., excavating, cutting, and filling), final grading, and creation of soil and vegetation stockpiles requiring stabilization.
- Cessation, temporarily or permanently, of construction activities on-site, or in designated portions of the site.
- The dates for final or temporary stabilization of areas of exposed soil.
- Removal of temporary storm water conveyances/channels and other storm water control measures, removal of construction equipment and vehicles, and cessation of any pollutant generating activities.
- Minimize the area of active construction. Limit maximum surface area of earth material exposed at any time to 300,000 square feet. Do not expose or disturb surface area of earth material until BMP measures are installed and accepted in writing by the Engineer.
- Inspect the site prior to initiation of ground-disturbing activities to verify BMPs, as required by the approved *BMP Plan* and/or other documents, have been installed correctly per the manufacturer's specifications and in the correct location.
- Date and sign the *Site-Specific BMP Plan (SSBMP)* or *SWPPP*, keeping an approved copy of the plan on-site or at an accessible location so that it can be made available at the time of an on-site inspection or upon request by the Engineer, per *2005 Hawaii Standard Specifications for Road and Bridge Construction*, Special Provisions Section 209.03(A)(h).
- After the *SSBMP Plan* or *SWPPP* is accepted in writing, schedule a water pollution, dust, and erosion control meeting with the Engineer a minimum of 7 calendar days prior to the start work date.
- Minimize work involving soil-disturbing activities during rain and forecasted events.
- Schedule disturbed areas to be stabilized prior to additional grading of other areas.
- Minimize duration of time trenches remain open. Schedule trenching activities to ensure trenches are closed prior to excavating new trenches.
- Periodically review the schedule for upcoming tasks. Prior to any new activity or new area opened for work, review the *SWPPP* to ensure BMP measures are appropriate to the site and/or means and methods of work. If not, a *SWPPP* amendment should be proposed by the Contractor and certified by HDOT prior to any change to the *SWPPP*. An approved/signed amendment must be in place prior to the start of work.
- Immediately initiate stabilization of exposed soil areas upon completion of earth-disturbing activities for areas permanently or temporarily ceased on any portion of the site. Stabilization must be completed no later than 14 calendar days after the initiation of stabilization measures.



Scheduling

Installation and Implementation Requirements *(continued)*

- All BMPs must be in place at the start of construction unless stipulated otherwise in the *SWPPP*.
- Refer to Hawaii Administrative Rules (HAR) Title 11, Chapter 55, Appendix C or project specifications for information on inspection and maintenance scheduling requirements.

Considerations

- Adherence to schedule.

What to Inspect

- Does the schedule reflect actual construction activities?
- Is there new work starting on-site?
- Does the *SWPPP* need to be amended?
- Are amendments approved prior to the start of work?

Maintenance

- Monitor progress of construction activities relative to construction schedule. Implement remedial measures if progress deviates from schedule.
- Revise the schedule, as necessary.

Location of Potential Sources of Sediment



Description

Practices and procedures to identify potential sources of sediment to reduce sediment discharge from construction sites.

Applications

- Any potential source of sediment on all projects.

Installation and Implementation Requirements

- Configure construction site to ensure vegetated areas buffer haul roads, stockpiles, and adjacent waterbodies. Vegetation provides an effective means of reducing sediment and pollutants discharged off-site.
- Place stockpiles away from waterways, drains and low spots.
- Direct off-site runoff away from bare ground.
- Maintain vegetation in swales and natural drainage ways.
- Designate naturally level areas for parking and equipment staging during construction.
- Inspect the construction site during or immediately following a rain event to identify the storm water's natural path to locate where sediment leaves the site. This will assist in *Storm Water Pollution Prevention Plan (SWPPP)* design and BMP placement.



Location of Potential Sources of Sediment

What to Inspect

- Where are the exposed areas on the construction site?
- Is there evidence of run-on and/or runoff?

Maintenance

- Install, repair, or replace BMPs to cover exposed areas or redirect off-site runoff.



Description

An approved location, designated in the *Storm Water Pollution Prevention Plan (SWPPP)*, where construction equipment, vehicles, materials, and other construction-related materials are stored. Staging areas can be a significant point source for pollution, so BMPs are necessary to ensure no contaminated storm water exits the site.

Applications

- Flat areas with ample space for equipment and materials to be stored.
- Paved areas and/or land already disturbed within project boundaries.

Installation and Implementation Requirements

- Staging areas must be defined in the plans of the project's *SWPPP* and approved prior to using the area. The approved locations and layout/detailing of the staging area must be included in the *SWPPP* or included by amendment process. In the case of roadside staging areas for paving equipment, a generic layout may be provided for multiple roadside identified locations. The approved staging area plan shall designate the locations of the equipment/material to be stored within the staging area, as well as, any BMPs to be implemented for the staging area.
- BMPs must be in place prior to using the staging area.
- Drip pans can be used to catch potential leaks from idle vehicles and equipment.
- Place drip protection/pads with absorbent and impermeable materials under all vehicles and equipment with the potential to leak/spill when not in use.

Installation and Implementation Requirements *(continued)*

- Perimeter controls must be placed along the perimeter of the staging area and underneath the impermeable material, to create a berm able to contain any possible spills and/or leaks.
- Perimeter control devices installed along the perimeter of the staging area diverts storm water run-on and runoff. For sloping areas where storm water can run onto the project site, consider installing a diversion to prevent off-site storm water from entering the project site.
- Do not store materials or equipment on perimeter controls. Material and equipment must be stored away from the perimeter controls to allow access for inspection and maintenance of the controls.
 - Commonly used BMPs include:
 - Silt fences
 - Compost filter socks or berms
 - Berms
- Consider phasing construction staging areas to minimize the duration of exposed soil. Dust control must be used on all exposed soils or any construction activity generating soil. *See* section SM-19 Dust Control for more information.
- When a phase of the project is complete and the staging area for the site is no longer required, immediately initiate stabilization at the disturbed areas. Once the area is deemed stabilized, the BMP devices can be removed. *See* section EC-12 Seeding and Planting for more information.
- Install a stabilized construction entrance/exit at the entrance of the staging area to prevent tracking onto adjacent paved roads and sidewalks. *See* section SC-11 Stabilized Construction Entrance/Exit for more information.
- All storm drain inlets that may intercept sediment-laden runoff from staging areas must be protected. *See* section SC-1 Storm Drain Inlet Protection for more information.
- Place drip pans or drop cloths under vehicles and equipment to absorb spills or leaks. *See* sections SM-10 Spill Prevention and Control and SM-12 Vehicle and Equipment Maintenance for more information.
- Store paving equipment and vehicles that are idle in a designated staging area on a layer of geotextile filter fabric on top of 10 mil plastic sheeting. Place drip pads/pans under paving equipment to contain leaks and spills. Drip protection is required under asphalt hopper and roller assembly. *See* section SM-20 Paving Operations for more information.



Aerial view of a construction staging area.

Installation and Implementation Requirements *(continued)*

- Ensure that construction vehicles and equipment are not stored under tree drip lines or on top of existing tree roots. *See* section SM-17 Preservation of Existing Vegetation for more information.
- Metal (galvanized and ungalvanized) and rebar must be stored off of the ground on proper dunnage, pallet, or similar material and covered with 10 mil plastic sheeting to prevent material from coming into contact with storm water. *See* section SM-2 Material Storage and Handling for more information.
- Locate stockpiles a minimum of 50 feet, or as far as practicable, from concentrated runoff, drainage systems, or open waterbodies. Stockpiles must be entirely covered with an impermeable material and surrounded by a perimeter control device installed around the base of the pile. Staging area perimeter protection cannot be used as perimeter protection for stock/spoil piles. *See* section SM-3 Stockpile Management for more information.
- Sanitary facilities must be secured and located away from drainage systems and open waterbodies. *See* section SM-7 Sanitary Waste Management for more information.
- Waste bins must be covered by the end of each work day and emptied when they reach two-thirds capacity. *See* section SM-6 Solid Waste Management for more information.
- Hazardous materials and waste such as: creosote pipes, waste asphalt, contaminated soil and transite pipes must be properly stored and covered. *See* section SM-9 Hazardous Materials and Waste Management for more information.
- Concrete wash areas must be lined with an impervious material and disposed of in compliance with federal, state, and local standards. *See* section SM-4 Concrete Wash and Waste Management for more information.
- For shared staging areas, responsibilities must be clearly defined. If the staging area is divided by well-defined boundaries for each project, each area can be covered under its respective Notice of General Permit Coverage (NGPC)/National Pollutant Discharge Elimination System (NPDES) permit. If a staging area is shared in its entirety, a separate NGPC/NPDES permit may be obtained for the staging area.
 - All areas within a shared staging area must be accounted for and there should be no overlapping areas for which responsibilities are shared by more than 1 contractor. Consult with the Engineer for review/approval.



Store vehicles and equipment on a layer of geotextile filter fabric on top of 10 mil plastic sheeting when not being used.

Installation and Implementation Requirements *(continued)*

- Off-site staging areas need to be included in the project's *SWPPP* and are subject to NPDES requirements.

Considerations

- Staging area may have a limited amount of space to store vehicles and equipment due to local traffic and existing vegetation.
- Storm water run-on from a point source upgradient becomes the contractor's responsibility to manage if it enters the staging area.
- Contractor may need to implement dust control measures if staging area is not stabilized.
- Runoff flows increase on paved and graded areas. Special attention will be needed during heavier rain events. Staging areas need to be secured prior to a severe storm event.
- Staging areas must be approved before storing materials and equipment in the area.
- Additional staging areas added to the project, outside of the project limits, may require a separate NPDES permit.

What to Inspect

- Are approved staging areas identified in the project's *SWPPP*?
- Are BMPs installed prior to vehicles and equipment being stored in the staging area?
- Are there leaks and/or spills evident around construction vehicles, equipment or materials?
- Is the correct size aggregate being used in staging area for construction roads and entrances?
- Are waste bins covered when not in use?
- Are portable toilets secured to prevent tipping or knocking over?
- Is rebar and steel under cover/covered with 10 mil plastic sheeting and properly stored on dunnage, pallet, or similar material?
- Are construction vehicles stored under existing tree drip lines or on top of tree roots?
- Are vehicles tracking sediment onto public roads?
- Are there traces of run-on or runoff around the perimeter of the staging area?
- Has the contractor initiated stabilization in disturbed areas no longer required for staging?



Staging Area

Maintenance

- Immediately clean up spills using dry cleanup methods where possible, and dispose of used materials properly.
- Clean up leaks and spills with an absorbent material. Do not clean surfaces or spills by hosing the area down.
- Provide an ample supply of readily available spill cleanup materials.
- Repair/replace plastic sheeting and/or geotextile filter fabric when torn or ripped.
- Replenish surface and construction entrance aggregate periodically.
- Repair/replace perimeter control devices that are tampered with and not functioning as designed.
- Place drip pans under idle construction vehicles.
- Adjust, repair, and/or reinstall inlet protection devices that are damaged, out of position, or not fully functional according to manufacturer's specifications.
- Regularly dispose of garbage and waste material.
- Amend the project's *SWPPP* when additional staging areas are needed or existing staging areas are no longer required.

Staging Area

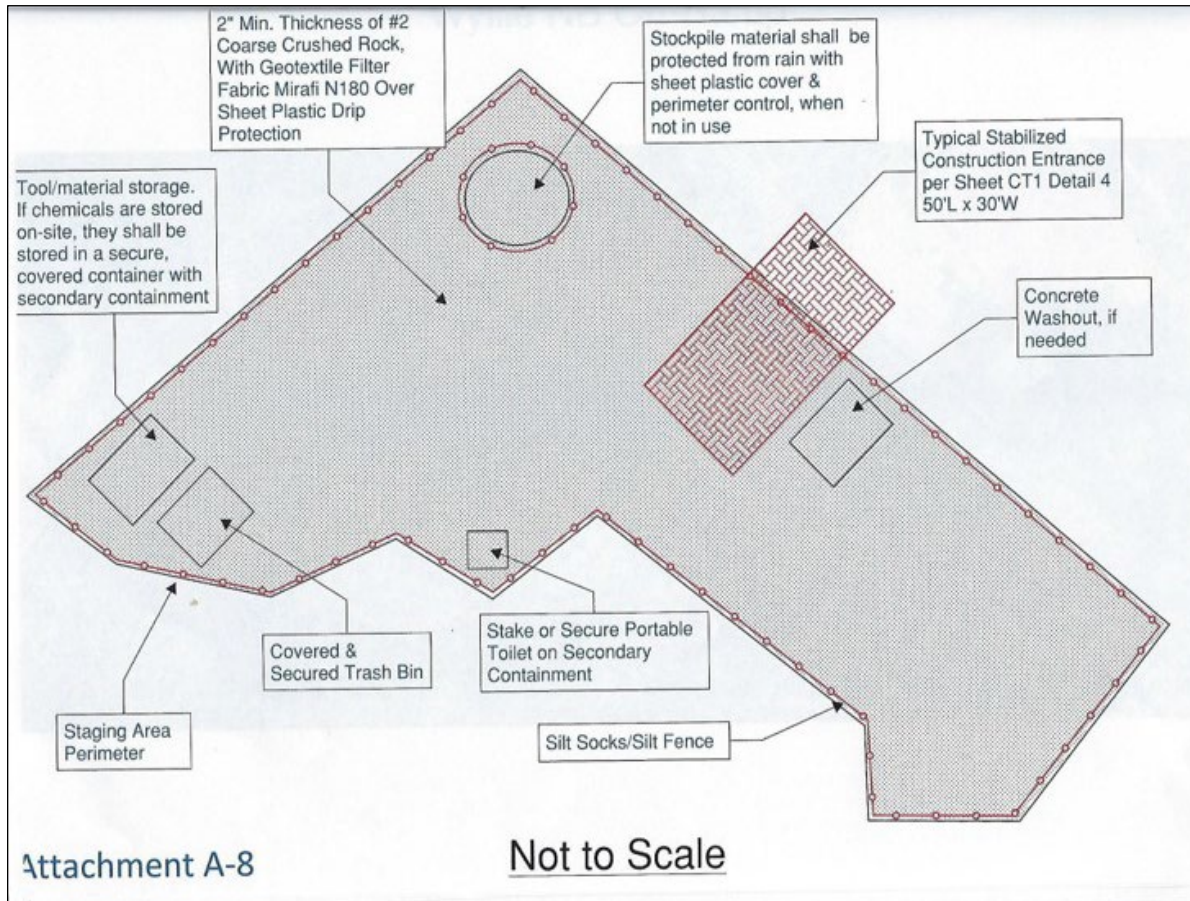

Example of a typical staging area.

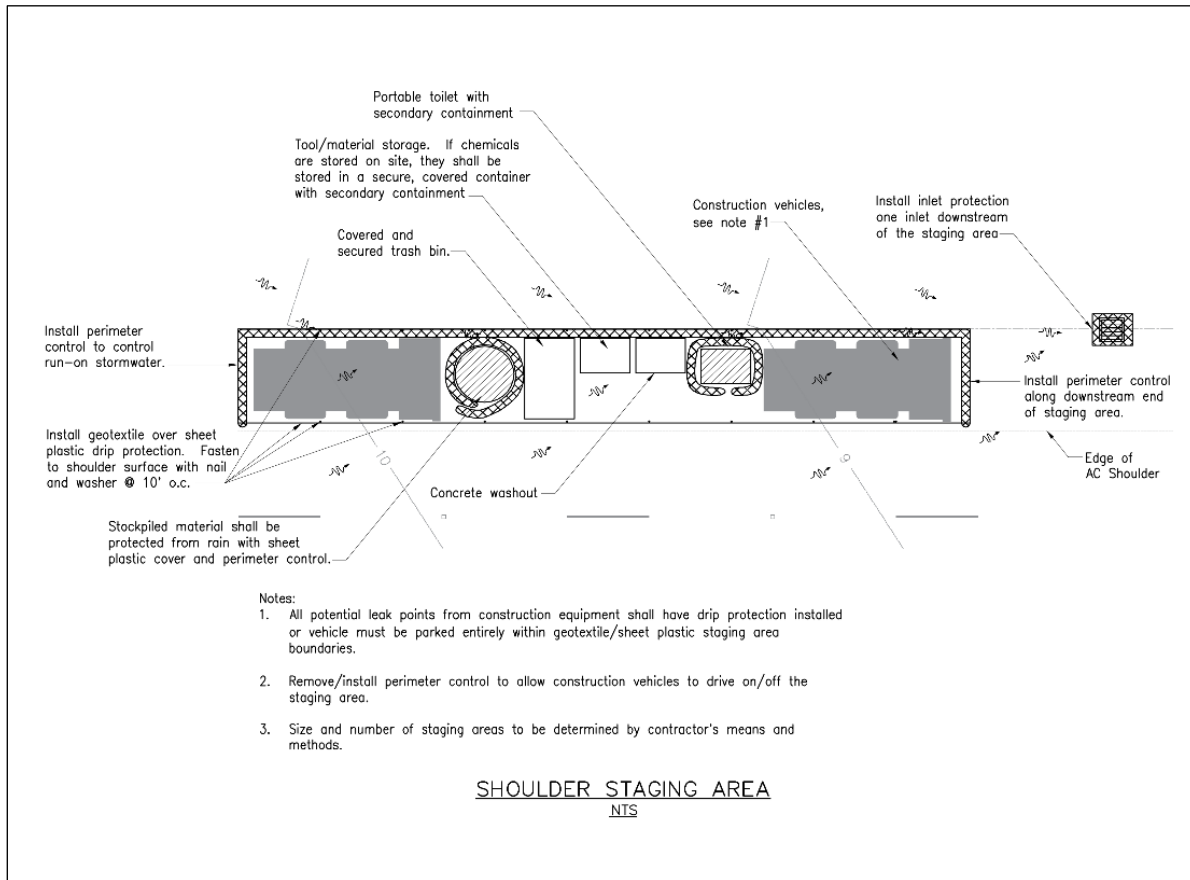

Example of a typical shoulder staging area.



Description

Practices and procedures to provide erosion and sediment control to preserve existing vegetation on a site with future land-disturbing activities.

Applications

- Areas on-site where no construction activity occurs or will occur at a later date.
- Areas where the existing vegetation should be preserved such as steep slopes, watercourses, and building sites in wooded areas.
- Natural resources or environmental protection areas requiring preservation by federal, state, and local governments such as wetlands and marshes.

Installation and Implementation Requirements

- Incorporate existing vegetation into landscaping plans when possible. Proper care of this vegetation before and after construction is required.
- Consider aesthetic and environmental values, tree/plant health, life span, sun exposure limitations, and space requirements when determining which vegetation to preserve.
- Avoid using vegetation which competes with the existing vegetation when preparing the landscaping plans.
- Phase construction activity to minimize the total amount of disturbed area to preserve existing vegetation.

Installation and Implementation Requirements *(continued)*

- Clearly identify land to be disturbed to avoid damaging existing vegetation that is not meant to be disturbed.
- Establish setback distances defined by devices such as berms, fencing, or signs. Setback distances are based on vegetation species, location, size, and age. Consider the type of construction activity in the vicinity of the vegetation. Construction activities are not permitted within the setback.
- Protect existing vegetation using the following methods:
 - Mark, flag, or fence areas of vegetation to be preserved.
 - Designate limits of root system (tree drip line).
 - Identify tree wells and retaining walls which are large enough to protect the root system.
 - Limit grading to within 1 foot of the tree drip lines, if grading under the tree is necessary.
 - Locate construction traffic routes, spoil piles, etc. away from existing vegetation.
- Consult with a licensed arborist to develop a plan if it is not possible, due to construction requirements, to provide a setback to the limits of the root system (tree drip line). This plan should include setback limits and other mitigation methods to provide protection for the subject tree or other vegetation.
- Do not park equipment on tree roots or near endangered species of vegetation.
- Consult with the appropriate agencies to approve any setbacks established if endangered species of vegetation are found within or adjacent to the project limits.



Steel plates were installed under the tree drip line to protect the root system after consultation with a licensed arborist.

Considerations

- Requires advanced planning and coordination among the owner/developer, contractor, and designer.
- Limited use if final site design does not incorporate existing vegetation.
- Diverse site topography may result in additional expenses to satisfy vegetation preservation and the grading required for the site improvements.
- Limited space for construction activity makes it difficult to preserve existing vegetation.

What to Inspect

- Are any endangered species identified within the projects limits and protected prior to the start of construction?
- Is there construction equipment, materials, personal vehicles or spoil piles stored on a tree's root system?
- Is construction activity occurring within vegetation setback limits?



Construction equipment and materials, personal vehicles, and spoil piles must not be stored on a tree's root system.

Maintenance

- Immediately repair or replace damaged protection measures.
- Damage to existing trees should be examined and attended to by an arborist.



Description

Practices and procedures to prevent or reduce the discharge of pollutants in non-storm water and accumulated precipitation from areas requiring dewatering activities so construction activity may proceed.

Applications

- Construction sites requiring the removal of non-storm water to create a dry work area or to remove the accumulation of non-storm water from a work area.

Installation and Implementation Requirements

- Dewatering non-storm water into storm drains and open bodies of water is prohibited without approval from the State of Hawaii Department of Health, Clean Water Branch (CWB).
- The Engineer must submit a complete Notice of Intent for Hawaii Administrative Rules (HAR) Title 11, Chapter 55, Appendix G, NPDES General Permit Coverage Authorizing Discharges Associated with Construction Activity Dewatering, no later than 30 days before the proposed starting date of the discharge or 30 days before the expiration date of the applicable notice of general permit coverage.
- The permittee shall comply with all requirements from HAR Title 11, Chapter 55, Appendix G and Appendix A, Standard General Permit Conditions. In case of conflict between the conditions listed in Appendix G and Appendix A, the more stringent conditions shall apply.

Installation and Implementation Requirements *(continued)*

TYPES OF POLLUTANTS FROM DEWATERING DISCHARGES

- Sediment
- Toxics and petroleum products
 - Due to the nature of dewatering operations, high sediment content is common. Toxics and petroleum products, however, are not prevalent unless heavy industrial activities or groundwater contamination occurred in the surrounding area.



Dewatering pits may be pumped with water from dewatering operations so construction activity may be accomplished.

SEDIMENT REMOVAL

- Use sediment controls such as a sediment trap to remove sediment from dewatering discharges. *See* section SC-6 Sediment Trap for more information.
- Apply filtration methods to remove sediment from the sediment trap. These include:
 - Sump pit combined with a perforated/slit standpipe, which is wrapped in geotextile filter fabric. As water collects in the pit, stones placed around the standpipe filter the water, which collects in the pit prior to being pumped out. Due to the wrapped standpipe, an increased suction inlet area may be required to prevent clogging and unacceptable pump operation.
 - Floating suction hose, which allows cleaner surface water to be pumped out.

TOXICS AND PETROLEUM PRODUCTS REMOVAL

- Areas of known or suspected groundwater contamination shall be tested by a certified laboratory for known or suspected pollutants using methods detailed in 40 CFR Part 136. The laboratory shall enforce a quality assurance/quality control measures program. Comply with the dewatering requirements in subsection 209.03 (D) of the *2005 Hawaii Standard Specifications for Road and Bridge Construction, Standard Specifications & Special Provisions Section*, as in effect.
- Discharges to the sanitary sewer system shall receive approval from the State of Hawaii Department of Health (DOH) and the owner of the wastewater system. Additional testing and disposal requirements may be necessary.
- Testing of the dewatering effluent should be completed and the results identified prior to discharging to a receiving waterbody or storm drainage system.



Dewatering Operations

Considerations

- Contaminated water may be an indication of contaminated soil. *See* section SM-8 Contaminated Soil Management for more information.

What to Inspect

- Is contaminated water evident in excavated areas?
- Is discoloration, oily sheen, or odor observed?

Maintenance

- Remove and properly dispose of sediment collected in sediment control devices.



Description

Measures to minimize erosion and reduce the amount of dust generated by construction activities.

Applications

Dust control shall be used on all exposed soils or any construction activity generating dust. Dust control shall apply to the following:

- Clearing, grubbing, and grading
- Construction vehicular travel on unpaved roads
- Drilling and blasting
- Soil and debris stockpiles
- Excavation and handling of soil or aggregate from excavators, loaders, and backhoes
- Unstable soil areas
- Sawcutting, jack hammering and grinding
- Sifting operations

Installation and Implementation Requirements

- Minimize exposed areas through the schedule of construction activities.
- Anticipate the prevailing wind direction to determine BMP placement in order to minimize the amount of dust generated.

Installation and Implementation Requirements *(continued)*

- Identify and stabilize primary entrances/exits prior to commencement of construction to prevent tracking and dust generation.
- Direct construction vehicular traffic to stabilized roadways.
- Maintain dust screens until permanent ground cover has been established.
- Use methods to mitigate or eliminate the amount of dust produced, such as spraying water from water truck, using misters, chemical dust controlling agents, or combination thereof; hydromulching, keeping soil moist, and grassing.
- Light spray of water or use of vacuum can minimize dust when drilling, sawcutting, jack hammering or grinding.
- Do not overspray water for dust control purposes, which will result in runoff from the area.
- Prevent water from wetting vehicles, pedestrians, and existing pavements.
- Washing down of debris or dirt into drainage, sewage systems, or state waters is not allowed.
- Chemicals used as soil stabilizers for dust control must be approved by the Engineer before use.
- Large areas and stockpiles can be hydromulched with a tackifier (with or without seed) to prevent wind erosion/dust. *See* section SM-3 Stockpile Management for more information.
- Geobinders with surfacants may be used to minimize water consumption.
- Cover exposed surface of materials completely with tarpaulin or similar device when transporting aggregate, soil, excavated material or material that may be sources of fugitive dust.
- Utilize vegetation, mulching, sprinkling, and stone/gravel layering to quickly stabilize exposed soil.
- Comply with the *2005 Hawaii Standard Specifications for Road and Bridge Construction*, Standard Specifications & Special Provisions Sections 209 and 619, as in effect.



Spraying water on exposed areas and when drilling, sawcutting, jack hammering, or grinding helps mitigate the amount of dust produced on a construction site.



Not using dust control measures can result in excessive dust being generated by construction activities.

Considerations

- Daily or more frequent applications of water may be necessary since water is a short-term dust preventative.
- Erosion may result from overwatering.
- Oil may not be used for dust control since the oil may discharge into a drainageway or seep into soil.
- Some dust suppression chemicals may cause soil to become water repellent resulting in increased runoff.

What to Inspect

- Is there evidence of off-site runoff?
- Is dust being suppressed during construction activity?
- Are dust screens properly maintained?
- Is dust from the construction site impeding public safety or health?
- Is water being oversprayed?

Maintenance

- Install, repair, or replace BMPs to cover bare ground or redirect off-site runoff.
- Apply water as conditions require.
- Repair water truck leaks immediately.



Dust screens must be maintained until permanent ground cover has been established.



Description

Practices and procedures to prevent or reduce the discharge of pollutants into the storm drain system or adjacent waterbodies from paving, sawcutting, or grinding activities.

Applications

- Paving operations and activities including the following:
 - Paving equipment storage
 - Asphalt cleaning
 - Removal of existing asphalt or concrete
 - Concrete, asphalt, seal coat, tack coat, or slurry applications
 - Recycling of pavement

Installation and Implementation Requirements

- Limit paving operations during wet weather when possible.
- Store materials for paving activities away from concentrated runoff.
- Place drip pans/drip pads under paving equipment to contain leaks and spills. Clean up spills with absorbent materials immediately.
- Drip protection must be placed under entire asphalt hopper, roller assemblies and spray arms that are not being used. Place a layer of geotextile filter fabric on top of 10 mil plastic sheeting. Perimeter controls must be placed along the perimeter, underneath the impermeable material, to create a berm able to contain any possible spills and/or leaks.

Installation and Implementation Requirements *(continued)*

- Ensure full inlet and scupper protection per the *Storm Water Pollution Prevention Plan (SWPPP)* during application of tack coat, seal coat, slurry seal, and fog seal.
- Do not remove inlet protection until paving and striping operations are complete.
- Clean any asphalt from inlet protection immediately following paving to allow water to drain.
- Remove saw cuts or boring slurry from site by vacuuming.
- Provide storm drain inlet protection during sawcutting to prevent slurry from entering the storm drains. *See section SC-1 Storm Drain Inlet Protection for more information.*
- Use asphalt emulsions as prime coat when possible.
- Clean asphalt-coated equipment off-site.
- Clean up asphalt millings by the end of the working day and properly dispose of or recycle, as necessary.
- *See section SM-5 Concrete Wash and Waste Management for activities involving Portland cement concrete (PCC).*
- Keep an ample supply of cleanup material in case of a spill or leak. *See section SM-10 Spill Prevention and Control for more information.*



Idle paving equipment must be stored drip protection to contain leaks and spills.

ASPHALT CONCRETE PAVING

- Properly dispose of old or spilled asphalt. Collect and remove broken asphalt. Recycle asphalt when possible.
- If waste asphalt (new) must be stored, rather than removed, it must be stored on an impervious material, covered with impervious material such as 10 mil plastic sheeting and have full perimeter control. It cannot be stored in dirt or rubble spoil piles.
- Sweep excess sand and gravel to prevent discharge into the storm drainage system or adjacent waterbodies.
- Comply with storm water permitting requirements for industrial activities if paving requires an on-site mixing plant.



Properly vacuuming saw cut and boring slurry prevents the slurry from entering storm drain systems and adjacent waterbodies.

Considerations

- Restrict paving operations during wet weather to prevent contact between storm water and paving materials.
- Limited space to stage paving equipment.

What to Inspect

- Is there drip protection under paving equipment?
- Is inlet protection installed and well-maintained?
- Is there drip protection under paving equipment not being used?
- Are asphalt millings cleaned up at the end of the work day?
- Is paving equipment properly staged within project limits?
- Is there evidence of saw cut slurry entering the storm drain?



Vacuuming without a filter creates a dust cloud of sawcutting fines.

Maintenance

- Keep an ample supply of drip pans and absorbent materials on-site.
- Regularly maintain paving equipment to minimize potential leaks or drips.



Description

Practices and procedures to reduce or prevent the discharge of pollutants from structure construction and painting activities into the storm drain system or adjacent waterbodies. Pollutants include solvents, paints, paint and varnish removers, finishing residues, spent thinners, soap cleaners, kerosene, asphalt and concrete materials, epoxy compounds, adhesive residues, and old asbestos insulation.

Applications

- Construction or maintenance activities involving painting or structure repair and construction.

Installation and Implementation Requirements

- Maintain a clean and orderly work site.
- Use recycled or less hazardous products if practical.
- Comply with local air quality and Occupational Safety and Health Administration (OSHA) regulations during painting activities.
- Properly store paints, solvents, and epoxy compounds in appropriate secondary containment and under impermeable cover.
- Properly store and dispose waste materials generated from painting and structure repair and construction activities.
- Avoid drift by enclosing or covering painting operations.

Installation and Implementation Requirements *(continued)*

- Collect residue from sand blasting or scraping operations on a drop cloth. Dispose of this residue properly.
- Use appropriate application equipment to minimize overspray.
- Minimize inadvertent disposal of residual paints and other liquids by ensuring nearby storm drains are clearly marked.
- Inspect the storm drain system in the immediate work area and remove dirt or debris upon completion of the activity.
- Clean painting equipment used with water-based paints in a sink connected to the sanitary sewer system.
- Mix paints in a covered and contained area, when possible, to minimize adverse impacts from spills.
- Immediately clean up spills.
- Testing of waste generated from painting may be required to determine if any hazardous waste are present per the contract documents. *See* section SM-6 Solid Waste Management and SM-9 Hazardous Materials and Waste Management for more information on proper disposal of solid and hazardous waste.
- Comply with applicable laws and regulations for recycling/disposal of residual paints, solvents, lumber, and other materials.
- Treat paint chips containing lead or tributyl tin as hazardous waste. *See* section SM-9 Hazardous Materials and Waste Management for more information.
- Properly dispose of material from sand blasting activities. Consider chips and dust from marine paints or paints containing lead as hazardous waste. Sweep paint chips and dust from non-hazardous dry stripping and sand blasting and dispose of as solid waste. *See* sections SM-6 Solid Waste Management and SM-9 Hazardous Waste Management for more information on proper disposal of solid and hazardous waste.



Maintaining a clean and orderly work site reduces or prevents the discharge of pollutants from structure construction and painting activities from entering the storm drainage system or adjacent waterbodies.

Considerations

- Availability of recycled or less hazardous products may be limited.
- Hazardous waste which may not be recycled or reused shall be disposed of by a licensed hazardous waste transporter.



Structure Construction and Painting

Considerations *(continued)*

- Storm water quality protection measures shall comply with OSHA and air quality regulations

What to Inspect

- Is there evidence of paint entering the storm drain system or adjacent waterbodies?
- Are paints and solvents properly stored?
- Is paint and construction repair waste disposed of properly?
- Are inlet protection devices installed at inlets in the direct vicinity of structure construction and painting?
- Are inlet protection devices properly installed and maintained?
- Are any leaks or spills evident where painting materials are being stored?

Maintenance

- Keep materials and equipment for proper housekeeping and disposal practices readily available.



Description

Practices and procedures to manage the reuse of native topsoil and other selected materials during revegetation activities. Salvaging, stockpiling, and reapplication of native topsoil is integral to successful revegetation efforts, especially for the reestablishment of native vegetation.

Applications

- Reestablishment of areas where vegetation with native plant species is desirable.
- Appropriate for sensitive habitat areas, floodplains, wetlands, and stream banks.

Installation and Implementation Requirements

- Preserve native topsoil where practicable.
- Conduct a site-specific soil survey of the area prior to soil-disturbing activities to assess the location, depth, and amount of soils suitable for salvaging.
- Salvage and stockpile all suitable topsoil and other material for future use during revegetation of the area. *See* section SM-3 Stockpile Management for more information.
- Carefully remove shrubs suitable for revegetation and store with the roots covered with mulch or loose soil.
- Apply topsoil or growth medium directly to disturbed areas and seed once construction activity is complete. Water area daily until the area is stabilized. However, avoid over-watering which can create runoff and erosion.

Installation and Implementation Requirements *(continued)*

- Restrict vehicle/equipment use in areas where vegetative stabilization will occur to avoid soil compaction.
- Soil replacement depths are determined by factors such as soil depth prior to disturbance, type of vegetation, and physical and/or chemical properties of the material to be covered. A deeper soil layer is required for soils with poor physical and chemical properties. Testing (nutrients, pH, and toxicity factors) of replacement soils and material to be covered shall be completed prior to reapplication.

TOPSOIL MANAGEMENT CONSIDERATIONS

- Quality and amount of native topsoil or growth medium.
- Area of surface disturbance to which topsoil or growth medium will be applied and the required depth of application.
- Methodology for salvaging topsoil or growth medium.
- Stockpile location, duration of storage, and required erosion control measures to protect stockpile.
- Feasibility of direct application of salvaged soils.
- Availability of other growth media to supplement topsoil reclamation.

Considerations

- Stockpiles may limit the area available for construction activity.
- Runoff from stockpiles may adversely impact water quality.
- Topsoil is contaminated prior to the start of construction activity.
- Avoid placement of topsoil prior to expected rain events.

What to Inspect

- Is topsoil effectively stockpiled?
- Are BMPs maintained to effectively prevent contact with storm water?
- Is dust originating from stockpiles?

Maintenance

- Adequately water plantings until they are established.
- Replace/repair damaged stockpile cover, as needed.
- Ensure that the plastic cover is in contact with the ground around the entire pile and properly anchored.
- Replace/repair damaged temporary perimeter sediment barrier.
- After the stockpile has been removed, revegetate the disturbed area, if applicable. Reapply temporary stabilization (i.e., hydromulch, tackifier, etc.), if needed.



Topsoil stockpiles must be fully covered with an impermeable material and protected with a temporary perimeter sediment barrier.



This page intentionally left blank.



CHAPTER 2. EROSION CONTROL

Erosion Control (EC) BMPs are devices installed on a construction site that reduce the erosion potential resulting from land-disturbing activities. EC BMPs serve as prevention measures by stabilizing soil. They are the primary measures of reducing the negative impact of construction activities by preventing storm water pollution.

In this chapter:

- General Practices
- Temporary Concentrated Flow Controls
- Soil Stabilization



Description

Temporary structures placed across a waterway to provide vehicular access while minimizing or reducing erosion and sedimentation.

Applications

- Streams or dry channels subject to frequent vehicular crossings.
- Detour roads on bridge replacement projects.

Installation and Implementation Requirements

- Design should be by a registered civil and/or structural engineer knowledgeable in stream flows, soil strength, and hydraulic and construction loading requirements.
- Provide stability in crossing and adjacent areas to withstand design flow. Choose a crossing site where erosion potential is low.
- Consider construction during dry periods to minimize disturbance and flow levels.
- Install means to trap sediment downstream of crossing.
- All materials used in construction should be clean, washed material with a cellular confinement system to prevent downstream contamination.
- Stabilize construction roadways (*See* section SC-10 Construction Roads and Parking Area Stabilization), adjacent work areas, and stream bottoms against erosion.
- Any temporary artificial obstruction within flowing water should be built with material that does not introduce sediment or silt into the watercourse.

Installation and Implementation Requirements *(continued)*

- Temporary waterbody crossing should be built to minimize scour.
- Minimize disturbance to existing vegetation and immediately restabilize the waterway once construction activity is completed.
- Equipment operations that will encroach on the waterbody within the project must be free of grease, oil, fuel, and residues.
- Construction in waterbodies may require temporary stream diversion and dewatering.
- Restrain from excavating in waterways or embedding crossings.
- Minimize or eliminate the need to cross streams by using alternative routes, as applicable.
- Vehicle and equipment maintenance, fueling, storage and cleaning should not be conducted on temporary bridges.

CULVERTS

- Applicable to perennial or intermittent streams.
- Effective in controlling erosion.

FORDS

- Applicable to arid areas during the dry season.
- Low maintenance.
- Provides minimal erosion and sediment control.

BRIDGES

- Applicable to high velocity, steep gradient conditions.
- Where temporary restrictions in the channel are not allowed.

Considerations

- Duration of construction projects shall not exceed 1 year.
- Not applicable for general traffic use.
- Additional BMPs will be necessary during installation and removal to minimize soil disturbance.



Culvert crossings must be properly sized to minimize erosion and maintain stream flow.



Temporary Stream Crossing

Considerations *(continued)*

- Subject to permit requirements of the U.S. Army Corps of Engineers (USACE) and State of Hawaii Department of Land and Natural Resources (DLNR):
 - USACE 404 Permits
 - State of Hawaii Department of Health, Clean Water Branch (CWB) 401 Certifications
 - DLNR, Commission on Water Resource Management (CWRM)
- Stream Channel Alteration Permit (Refer to Hawaii Administrative Rules (HAR) Title 13, Chapter 169-50, Protection of Instream Uses).
- Waterways will be disturbed during installation and removal.
- For construction traffic only. Not intended for public use.
- Bridges generally cost more than alternative methods, but cause the least amount of disturbance to existing conditions.

What to Inspect

- Are channels blocked from stream crossing during rain events?
- Is there debris accumulated in culverts, behind fords, or under bridges?
- Is there evidence of abutment erosion, rip-rap displacement, channel scour, piping in soil and/or structural degradation?
- What is the turbidity of water downstream?

Maintenance

- Remove silt and debris periodically.
- Replenish aggregate from culvert inlets and outlets as necessary.
- Remove temporary crossings once no longer needed.

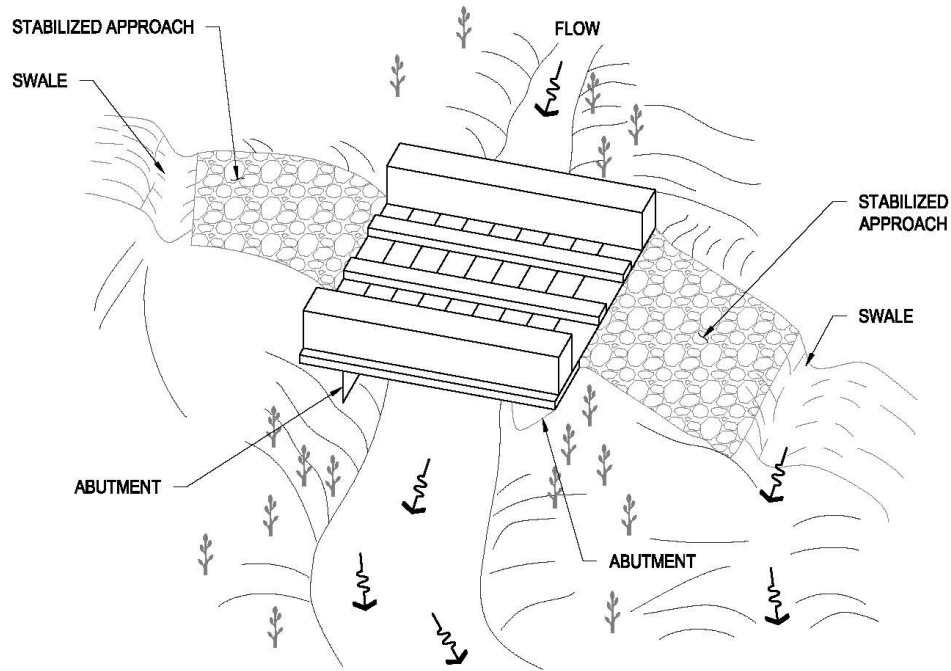

SURFACE FLOW OF ROAD DIVERTED BY SWALE AND/OR DIKE.

TYPICAL BRIDGE CROSSING
NOT TO SCALE

NOTE:

1. IF THE BRIDGE DECK CONTAINS OPENINGS, A CATCHMENT SYSTEM SHALL BE UTILIZED TO PREVENT SEDIMENT FROM FALLING TO THE SURFACE BELOW.

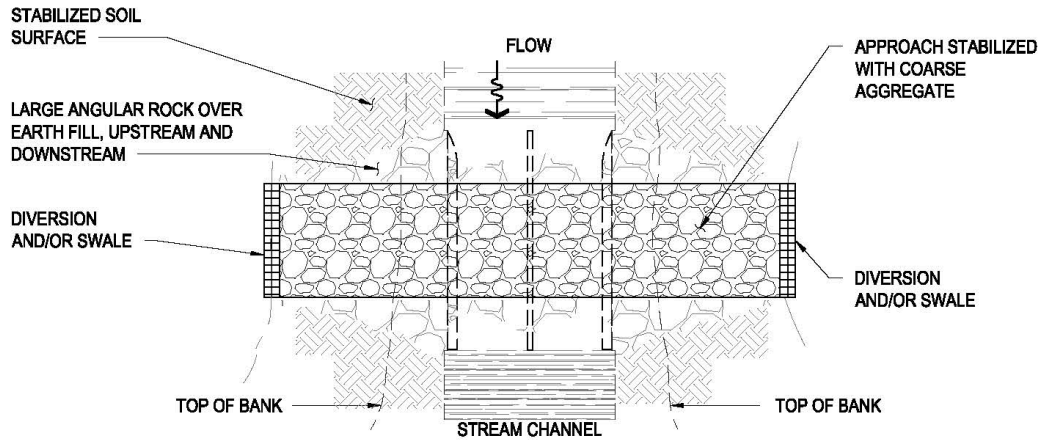

PLAN
NOT TO SCALE

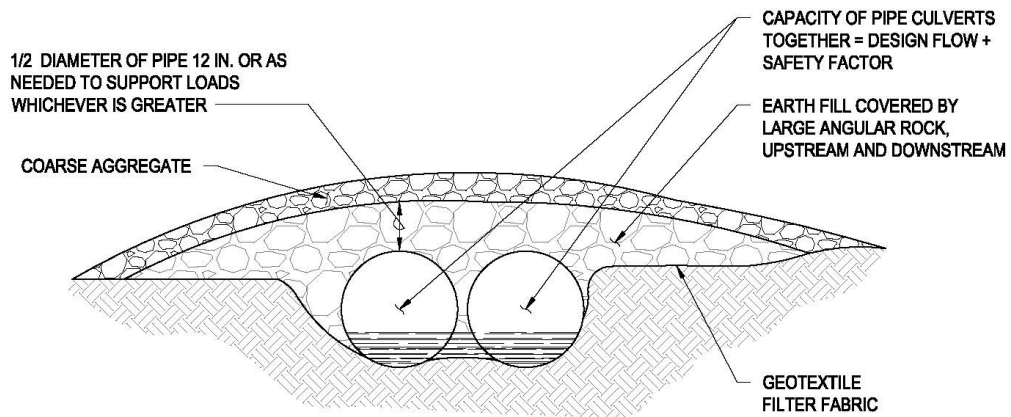

ELEVATION
NOT TO SCALE

TYPICAL CULVERT CROSSING

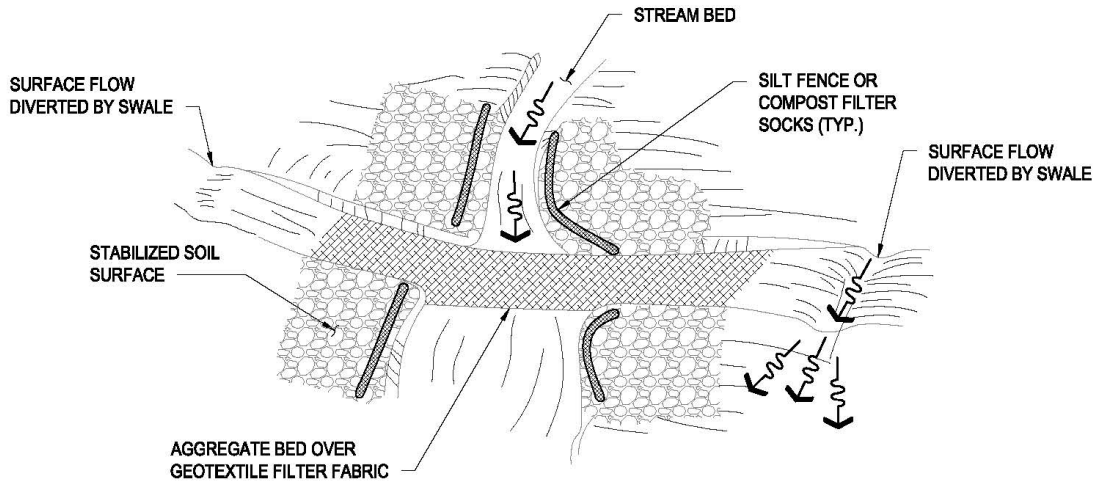

NOTE:
AGGREGATE APPROACH 5:1 (H:V) MAX. SLOPE ON ROAD

PERSPECTIVE VIEW
NOT TO SCALE

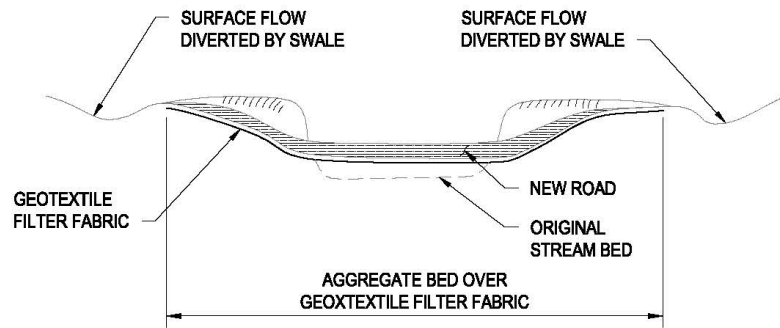

SECTION
NOT TO SCALE

TYPICAL FORD CROSSING

- NOTES:**
1. COMPOST FILTER SOCKS MAY BE INSTALLED ABOVE THE HIGH WATER MARK (UPLAND) AS LONG AS THEY ARE MAINTAINED PROPERLY AND DON'T BECOME A POLLUTANT SOURCE.



Description

Devices placed at the inlet or outlet of pipes and channels to enhance hydraulic operation while minimizing scour and erosion.

Applications

- Flared culvert end sections may be placed at inlets and outlets of slope drains and culverts.

Installation and Implementation Requirements

- Construct on level ground where possible. Flatter slopes reduce the potential of erosion and scour.
- Supplement with additional outlet protection devices.
- Protect the transition to the flared end section at inlets to prevent scouring.
- Extend additional rip-rap downstream of outlet to reach stable conditions and minimize scouring. Ensure geotextile filter fabric is installed under rip-rap.
- All disturbed areas must be immediately stabilized with native vegetation once construction is complete.



Additional rip-rap with geotextile filter fabric installed underneath can be extended downstream of outlet to reach stable conditions and minimize scouring.

Installation and Implementation Requirements *(continued)*

- Monitor accumulation of debris and sediment and remove within 60 days of notification. Immediately clean culverts located where Class AA or Class 1 waters or highway safety may be adversely affected. Refer to Hawaii Administrative Rules (HAR) Title 11, Chapter 54 for state waters classification.
- Obtain guidance from the District Maintenance Engineer or Highways Division's Hydraulic Section and refer to Highways Division's Standard Plans.

Considerations

- Limited use as an erosion control measure. Primarily used to increase hydraulic efficiency.
- Improperly designed culverts could result in erosion, scouring, or ponding.
- Pipes can clog if they are not adequately protected from litter.
- Pipe outlets may cause critical levels of erosion if devices are not installed to dissipate the velocity of storm water flow.
- Additional erosion control BMPs will need to be added to slope drains on slopes greater than 10%, due to highly erosive velocities.
- The contractor may need to temporarily remove rip-rap to repair/replace geotextile filter fabric under rip-rap.

What to Inspect

- Is flared culvert end section installed correctly, per manufacturer's specifications?
- Is there evidence of scour around and beneath flared culvert end sections?
- Is there a non-storm water discharge observed from pipes?
- Is ponding occurring in traffic lanes or private property?
- Is geotextile filter fabric installed under rip-rap?

Maintenance

- Remove accumulated sediment from inlets, outlets, and rip-rap.
- Refresh rip-rap that has been dislodged.
- Add additional BMPs if erosion and scouring are observed.
- Repair geotextile filter fabric that has rips and/or tears.
- Remove temporary BMPs when drainage area is stabilized and construction is complete.

FLARED END SECTION (SEE
HDOT STANDARD PLAN H-24)

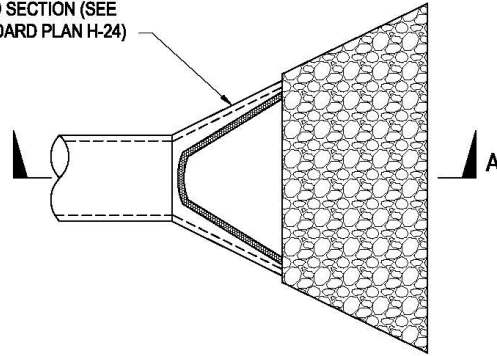

PLAN
NOT TO SCALE

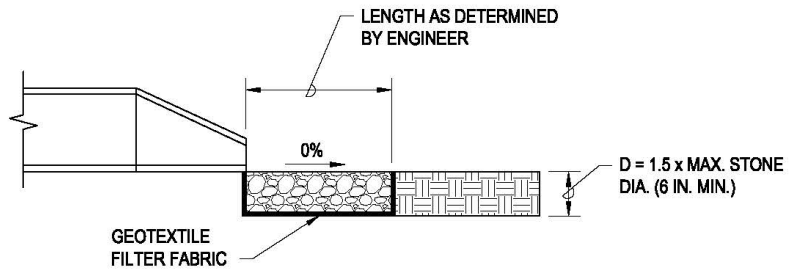

SECTION A
NOT TO SCALE

FLARED CULVERT END SECTION



Description

Devices that intercept, divert, and convey off-site surface run-on around or through the project site to prevent site erosion. Run-on (storm water entering the site) diversion devices include dikes, swales, compost filter berms, sandbags, check dams and slope drains.

Applications

- Along paved surfaces to intercept runoff.
- Upslope from project site to prevent erosion of disturbed areas located on-site.
- Downslope of project site to convey runoff to a sediment control device such as a sediment trap or sediment basin.
- Around material storage areas, maintenance and fueling areas, or areas with runoff containing contaminants or pollutants.
- Below steep grades to intercept concentrated runoff.
- Diversion devices can provide protection from storm water runoff when located around adjacent property and buildings.
- Devices can be used to divert run-on storm water through the construction site without eroding disturbed areas.



Devices can be used to divert run-on storm water through the construction site without eroding disturbed areas.

Installation and Implementation Requirements

- A designer should provide flow rate calculations to the Engineer for approval before installation to ensure the size of the diversion device is effective.
- Use a layered approach to divert storm water run-on and minimize sediment from leaving the site.
- Select flow velocity based on evaluation of potential risks due to erosion, overtopping, flow backup, washout, and drainage flow patterns of the project.
- Immediately stabilize earth dikes and swales. *See* section EC-5 Earth Dikes, Swales, and Ditches for more information.
- *See* section EC-7 Slope Drains and Subsurface Drains for more information.



A layered BMP approach can be used to divert storm water run-on and minimize sediment from leaving the site.

Considerations

- Run-on diversion devices do not remove sediment from runoff.
- If run-on cannot be diverted around the construction site it will need to be directed through the project without causing erosion.
- Ditches and swales may require check dams or lining to prevent erosion.
- All diversions shall have stabilized outlets that will convey concentrated runoff without erosion.
- Once storm water run-on enters a construction site, it becomes the contractor's responsibility to effectively manage.
- Not all devices are effective individually. A layered approach is more appropriate.

What to Inspect

- Is there evidence of sediment buildup at inlets?
- Is there erosion at channel embankments, washouts, or ditch beds?
- Is there evidence of erosion or scour at outlets and/or perimeter of site?
- Are there signs of storm water run-on entering the construction site?
- Is sediment accumulating at perimeter control devices?
- Are additional BMPs needed to prevent run-on?



Run-on Diversion

Maintenance

- Remove accumulated sediment and debris and repair damages as necessary.
- Temporary diversions shall be completely removed and area stabilized at the completion of construction.
- Repair/replace BMP devices that are not properly performing.

Slope Roughening, Terracing, and Rounding



Description

Methods of slope grading to reduce potential erosion by decreasing runoff velocities, trapping sediment, shortening slope length, and increasing infiltration into the soil.

Applications

- Areas where seeding, planting, and mulching erosion control measures may be enhanced by roughening of the soil surface. Graded areas with smooth, hard surfaces.
- Areas requiring terracing to shorten the slope length.
- Locations where vegetation is not adequate erosion protection and is affecting construction activity.

Installation and Implementation Requirements

CUT SLOPE ROUGHENING

- Cut slopes steeper than 3:1 (H:V) shall use stair-step grading or furrows.
- Use stair-step grading on soft soils that may be ripped by a bulldozer. Stair-step grading is particularly suitable for slopes consisting of soft rock with some subsoil.
- The vertical cut shall not exceed 2 feet in soft materials and 3 feet in rocky material.
- The vertical cut must be shorter than the horizontal cut. The typical stair width is 1 to 2 feet.

Slope Roughening, Terracing, and Rounding

Installation and Implementation Requirements *(continued)*

- Slope the horizontal cut towards the face of the slope, so storm water drains towards the slope and allows time for sediment to settle.
- Create ridges and depressions along the slope contours using machinery.

FILL SLOPE ROUGHENING

- Fill slopes steeper than 3:1 (H:V) shall be placed in lifts not exceeding 9 inches. Each lift shall be properly compacted.
- Slope faces shall consist of 4 to 6 inches of loose and uncompacted soil.
- Grooving or tracking shall be used to roughen slope faces as necessary.
- Apply seed, fertilizer, and mulch. Track or punch in the mulch. *See* section EC-14 Mulching and section EC-12 Seeding and Planting for additional information.
- The final slope face shall not be bladed or scraped.

CUTS, FILLS, AND GRADED AREAS

- Slopes that will be maintained by mowing shall be no steeper than 3:1 (H:V).
- Create shallow grooves by normal tilling, disking, harrowing, or use of a cultivator-seeder. Final pass of tillage shall be along the contour. Spacing between grooves shall be 10 inches or less. Groove depth shall be a minimum of 1 inch.

ROUGHENING WITH TRACKED MACHINERY

- Roughening with tracked machinery is only applicable to soils with a sandy texture. Other types of soil may be over-compacted by tracked machinery.
- Application is best for slope grades 3:1 (H:V) or flatter.
- Leave horizontal depressions in the soil by operating tracked machinery up and down the slope. During the final grading operation, do not back blade.
- Minimize the number of passes the tracked machinery makes to avoid over-compaction.
- Roughened areas shall be seeded and mulched for optimum seed germination and growth.



Machinery tracking must leave horizontal depressions on the slope soil. Horizontal depressions decrease runoff velocities, trap sediment, shorten slope length, and increase infiltration in the soil.

Slope Roughening, Terracing, and Rounding

Installation and Implementation Requirements *(continued)*

TERRACING

- Slope grades of 5:1 (H:V) shall include terraces or benches when slope heights exceed 30 feet. Steeper slope or highly erosive soil conditions may warrant terraces or benches for slope heights of 15 feet or higher.
- Runoff collected along terraces and benches shall be routed to lined diversion ditches. Install lined diversion ditches at the intersection of the terrace and slope.
- Vertical cut shall be between 1 and 2 feet. Horizontal cut must be longer than the vertical cut and slope inward towards the face of the slope. Benching width is usually made wide enough for mowing equipment.

ROUNDING

- All slopes shall be rounded with no sharp breaks in plan or profile.

Considerations

- Since terracing is permanent, design and approval shall be under the direction of a licensed, qualified engineer.
- Design of terraces shall provide adequate drainage and stabilized outlets.
- Roughening may result in increased grading costs and sloughing in soil.
- Stair-step grading are for cut slopes only and may not be applicable to sandy, steep, or shallow soils.
- During intense rainfall events, roughening may not be an effective temporary erosion control measure.
- Surface roughening must not be used to keep an area under the qualification of “actively working” to prolong the stabilization deadline.
- Slopes need to be regraded and reseeded if rills and gullies form, creating channels for runoff.
- Excessive compaction with tracking machinery can inhibit vegetation growth and cause higher runoff rates.



Terracing design and approval must be under the direction of a licensed, qualified engineer.



Slope Roughening, Terracing, and Rounding

What to Inspect

- Is there evidence of rills and gullies on seeded and planted slopes?
- Does the slope have adequate vegetation coverage?
- Are proper cuts and methods being used to reduce erosion?

Maintenance

- Regrade and reseed areas where rills or gullies have formed.
- Revegetate bare areas on slope.

Slope Roughening, Terracing, and Rounding

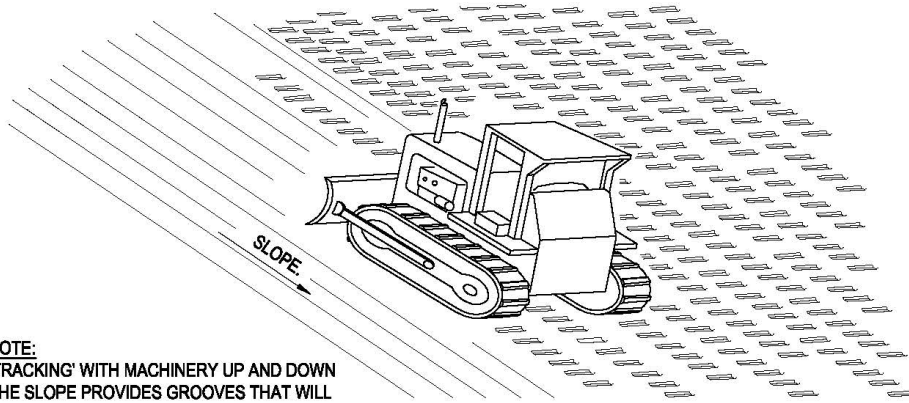

NOTE:
 'TRACKING' WITH MACHINERY UP AND DOWN THE SLOPE PROVIDES GROOVES THAT WILL CATCH SEED, FERTILIZER, RAINFALL, AND REDUCE RUNOFF.

TRACKING
 NOT TO SCALE

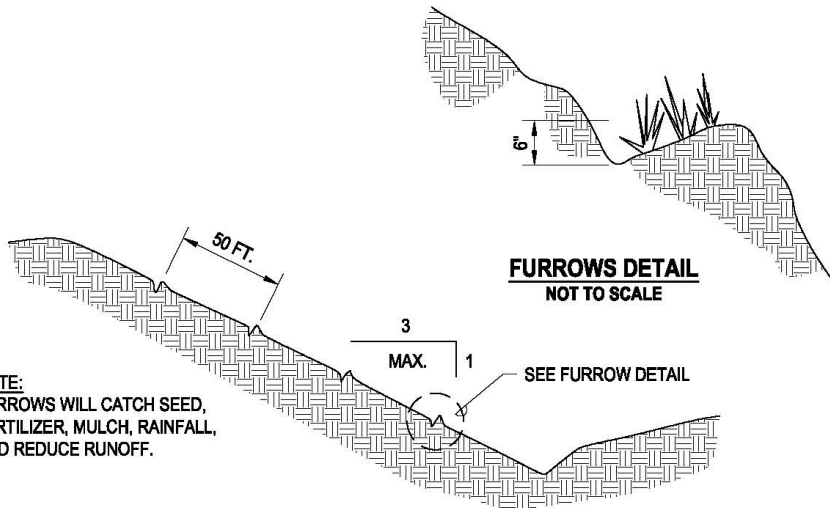

NOTE:
 FURROWS WILL CATCH SEED, FERTILIZER, MULCH, RAINFALL, AND REDUCE RUNOFF.

CONTOUR FURROWS
 NOT TO SCALE

Slope Roughening, Terracing, and Rounding

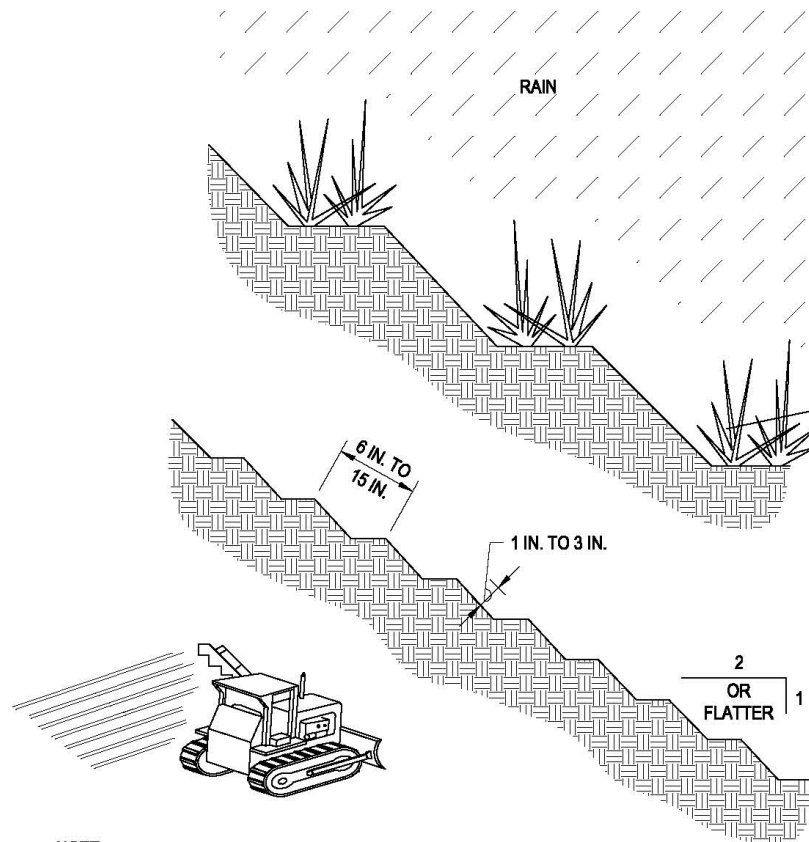

NOTE:
 GROOVE BY CUTTING SERRATIONS ALONG THE
 CONTOUR. IRREGULARITIES IN THE SOIL SURFACE
 CATCH RAINWATER, SEED, MULCH, AND FERTILIZER.

SERRATED SLOPE
 NOT TO SCALE

Slope Roughening, Terracing, and Rounding

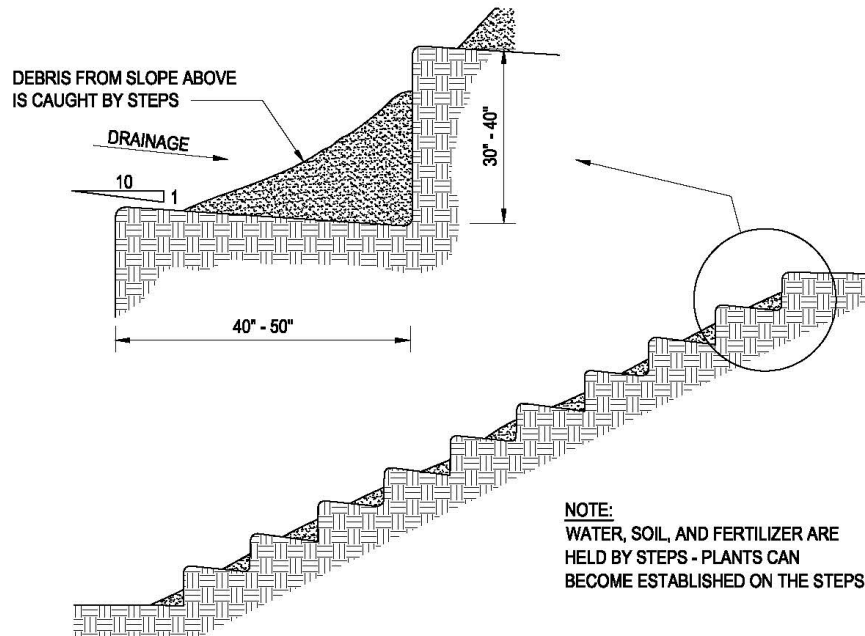

STAIR STEPPING CUT SLOPES
NOT TO SCALE



Description

Structures that prevent erosion by intercepting, diverting, and conveying surface run-on to a stabilized area or other sediment trapping device.

Applications

- Use earth dikes for drainage areas smaller than 10 acres.
- Use swales and ditches for drainage areas smaller than 5 acres.
- Direct runoff around unstable or disturbed areas to a stabilized water course, drainage pipe, or channel.
- Divert runoff to sediment basins or sediment traps.
- Along perimeter of the site or disturbed area to divert storm water run-on and runoff.
- Intercept runoff at the point of concentration.
- Supplement other sediment control measures.
- Intercept and divert runoff to prevent sheet flow over sloped surfaces.
- Convey surface runoff down sloping land.
- Provide containment for a specified and limited area including stockpiling or material storage areas within the project limits.

Installation and Implementation Requirements

EARTH DIKES

- Firmly compact to minimize erosion and prevent unequal settling.

Installation and Implementation Requirements *(continued)*

- Drain to a stabilized outlet.
- Divert sediment-laden runoff to a sediment trapping device.
- Ensure continuous, positive grade along dike to prevent ponding of runoff.
- Stabilize earth dikes with vegetation, chemicals, or other physical devices.
- Conform to predevelopment drainage patterns and capacities.
- Berm size is determined by factors including slope length and grade, soil characteristics, climate, and presence of existing vegetation.
- Obtain guidance from the District Maintenance Engineer or Highways Division's Hydraulic Section and refer to Highways Division's Standard Plans for dike design review. The review will evaluate structural stability and drainage capacity.
- Berms may be vegetated or unvegetated.
- Use velocity dissipation devices within and at the outlet of temporary drains and swales to minimize erosive flow velocities. *See* section EC-8 Outlet Protection and Velocity Dissipation Devices for more information.
- Determine design flow and safety factor by an evaluation of risks associated with overtopping, flow backups, or washout of structures.
- Evaluate potential run-on from off-site properties. Install before earth-disturbing activity on slopes.
- Determine flow velocity limit by on-site soil type and drainage flow patterns.
- Establish minimum flow velocity requiring lining (rip-rap, geotextile filter fabric, vegetation, concrete) for earthen diversion devices. Refer to Highways Division's *Statewide Uniform Design Manual for Streets and Highways* for more information.
- Incorporate an emergency overflow section or bypass area into the design for storms exceeding the design storm.



Swales and ditches can be used to intercept, divert, and convey surface run-on to a stabilized area or other sediment trapping device.

SWALES AND DITCHES

- If rip-rap is used, use 4- to 12-inch rock depending on the grade. Check with Highways Division's Hydraulics Section.
- Stabilize earth dikes, drains, and swales with vegetation, chemicals, or other physical devices.

Considerations

- Access and space can prohibit or limit the installation of a dike.
- Despite simplicity of installation, improper design can limit effectiveness.
- Use of additional sediment and erosion control devices may be required to prevent scour and erosion in recently graded dikes, swales, and ditches.
- Select size and location to prevent unintended consequences such as erosion along steep and unlined ditches and ponding within the travelway or material storage areas.
- Alteration of existing waterways and clearing of existing vegetation are subject to permit requirements of the U.S. Army Corps of Engineers (USACE) and state or local agencies.
- Unsuitable for use as a sediment trapping device.

What to Inspect

- Is there erosion along berms, channel linings, embankments, beds of ditches and downgradient?
- Is there excess sediment/debris evident in the swale?
- Is there sediment accumulation along dike?
- Is proper size rip-rap used?
- Will runoff remain within diversion channel?
- Are embankments stabilized?
- Is there evidence of potential signs of failure for dike walls, embankments, compacted fills, and earthen channel sidewalls?

Maintenance

- Restore all bare areas with the appropriate lining material.
- Remove accumulated sediment and debris once it reaches one-half the height of the dike.
- As needed, reseed/stabilize the dike as needed to maintain stability.
- Remove dikes, swales, and ditches after stabilization of the surrounding drainage area or completion of construction.
- Restore any cracks, washouts, animal habitation, exposed materials, or other signs of potential failure. Coordinate restoration with Maintenance Engineer or Material Testing and Research Section as necessary. The Hydraulic Section shall also be consulted for problems associated with structural design or runoff flow patterns.

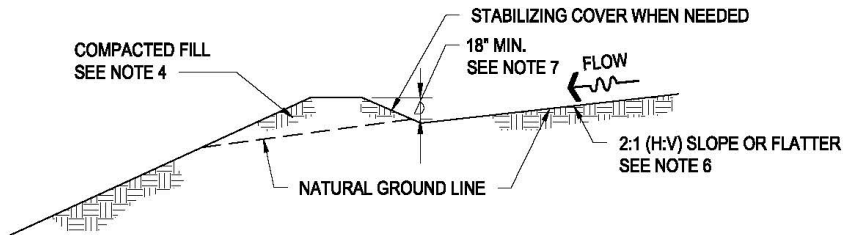

SECTION
NOT TO SCALE

NOTES:

1. ALL DIKES SHOULD BE COMPACTED BY EARTH MOVING EQUIPMENT.
2. ALL DIKES SHOULD HAVE POSITIVE DRAINAGE TO AN OUTLET.
3. ALL DIKES SHOULD HAVE 2:1 OR FLATTER SIDE SLOPES, 18 INCH MINIMUM HEIGHT, AND A MINIMUM TOP WIDTH OF 24 INCHES. WIDE TOP WIDTHS AND FLAT SLOPES ARE USUALLY NEEDED AT CROSSINGS FOR CONSTRUCTION TRAFFIC.
4. THE OUTLET FROM THE EARTH DIKE SHOULD FUNCTION WITH A MINIMUM AMOUNT OF EROSION. RUNOFF SHOULD BE CONVEYED TO A SEDIMENT TRAPPING DEVICE SUCH AS SEDIMENT TRAP OR SEDIMENT BASIN WHEN EITHER THE DIKE CHANNEL OR DRAINAGE AREA ABOVE THE DIKE ARE NOT ADEQUATELY STABILIZED.
5. TEMPORARY STABILIZATION MAY BE ACHIEVED USING SEED AND MULCHING FOR SLOPES LESS THAN 5% AND EITHER RIP-RAP OR SOD FOR SLOPES IN EXCESS OF 5%. IN EITHER CASE, STABILIZATION OF THE EARTH DIKE SHOULD BE COMPLETED IMMEDIATELY AFTER CONSTRUCTION OR PRIOR TO THE FIRST RAIN.
6. IF RIP-RAP IS USED TO STABILIZE THE CHANNEL FORMED ALONG THE TOE OF THE DIKE, THE FOLLOWING TYPICAL SPECIFICATIONS APPLY:

CHANNEL GRADE	RIP-RAP STABILIZATION
0.5-1.0%	4 IN. ROCK
1.1-2.0%	6 IN. ROCK
2.1-4.0%	8 IN. ROCK
4.1-5.0%	8 IN. - 12 IN. ROCK

EARTH DIKE

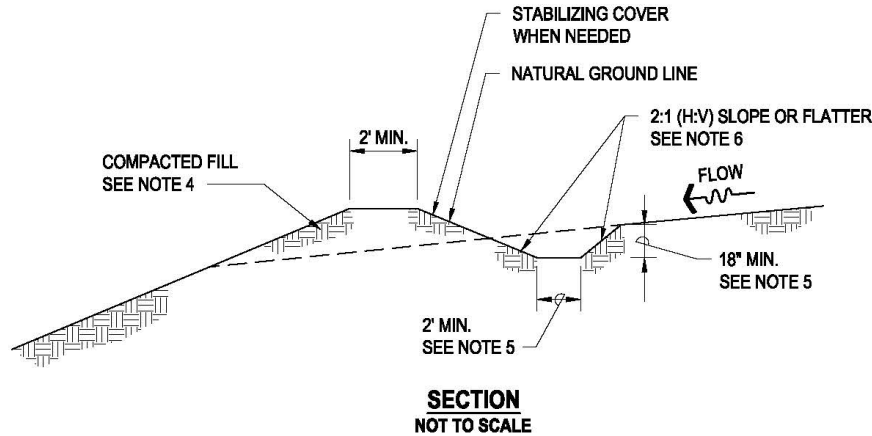

NOTES:

1. PLACE DRAINAGE SWALES ABOVE OR BELOW, NOT ON, A CUT OR FILL SLOPE.
2. DRAINAGE OR SWALES SHOULD BE LAID AT A GRADE OF AT LEAST 1 PERCENT, BUT NOT MORE THAN 15 PERCENT.
3. REMOVE ALL TREES, STUMPS, OBSTRUCTIONS, AND OTHER OBJECTIONABLE MATERIAL FROM THE SWALE.
4. FILL MATERIAL ALONG THE PATH OF THE SWALE SHOULD BE COMPACTED TO AT LEAST 90% COMPACTION.
5. SWALE TOP AND BOTTOM WIDTH SHOULD BE AT LEAST 2 FT.
6. SIDE SLOPES SHOULD BE 2:1 OR FLATTER.
7. DEPTH OF THE SWALE SHOULD BE AT LEAST 18 IN.
8. CONSTRUCT THE DRAINAGE SWALE WITH A POSITIVE GRADE TO A STABILIZED OUTLET.
9. USE A LINED DITCH FOR HIGH FLOW VELOCITIES.
10. TEMPORARY STABILIZATION MAY BE ACHIEVED USING SEED AND MULCHING FOR SLOPES LESS THAN 5% AND EITHER RIP-RAP OR SOD FOR SLOPES IN EXCESS OF 5%.
11. IF RIP-RAP IS USED TO STABILIZE THE CHANNEL FORMED ALONG THE TOE OF THE DIKE, THE FOLLOWING TYPICAL SPECIFICATIONS APPLY:

CHANNEL GRADE	RIP-RAP STABILIZATION
0.5-1.0%	4 IN. ROCK
1.1-2.0%	6 IN. ROCK
2.1-4.0%	8 IN. ROCK
4.1-5.0%	8 IN. - 12 IN. ROCK

TEMPORARY DRAINAGE SWALE



Description

Device used at outlets to convert concentrated flow to sheet flow, preventing erosion of the receiving area. Tops of channels, earthen berms, or rigid weir-like structures may function as level spreaders.

Applications

- Flat or gentle sloping areas.
- Outlets for dikes and diversions.
- Where concentrated flows are discharged.

Installation and Implementation Requirements

- Construct on undisturbed soil.
- Do not construct on fill material.
- Locate where reconcentration of water will not occur.
- A stabilized and well vegetated slope of less than 10% shall be located below the level spreader.
- Filter runoff containing high sediment loads through a sediment-trapping device prior to release to the level spreader.
- Incorporate a rigid outlet lip design for high discharge flows.
- 0% grade on the spreader lip is necessary for uniform sheet flow.
- Avoid operating vehicles and heavy equipment on the level spreader to maintain a smooth level surface for the overflow weir.



Level Spreader

Considerations

- Not applicable to sediment-laden runoff.
- The level spreader lip needs to be at a 0% grade to confirm no erosion or concentration of flows occur.
- Not recognized as a pollutant reduction BMP when by itself, but is necessary for other BMP devices to function properly. It will also remove some pollutants due to some suspended sediment that settles out.
- Storm water approaching the BMP should not be high energy.

What to Inspect

- Is there accumulated debris or sediment in the level spreader?
- Does the level spreader have a slope of 0% along the spreader lip?
- Is there evidence of erosion, channelization, or concentrated flow at the discharge area?
- Are there low spots in spreader?

Maintenance

- Keep level spreader at 0% grade.
- Remove any accumulated debris and sediment and properly dispose off-site.
- Mow grass to assure the level spreader is properly functioning.

Level Spreader

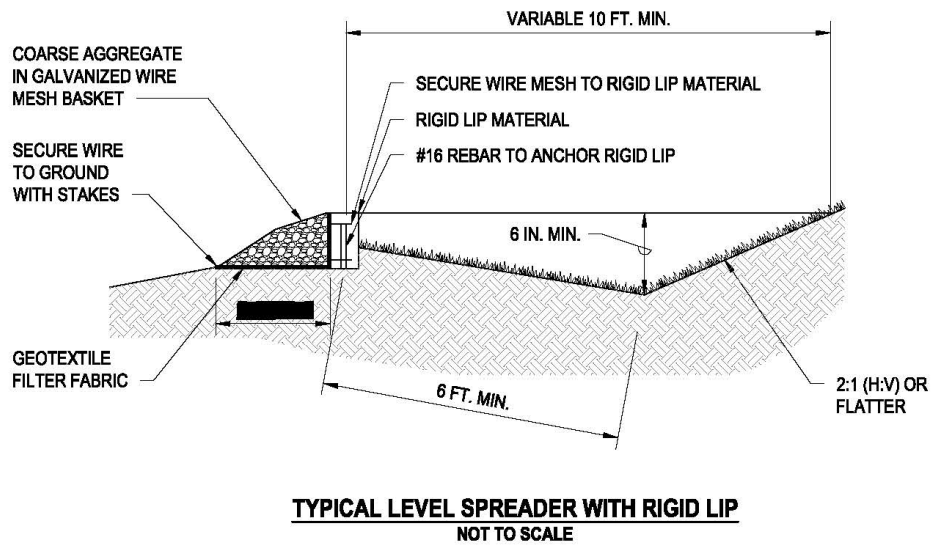
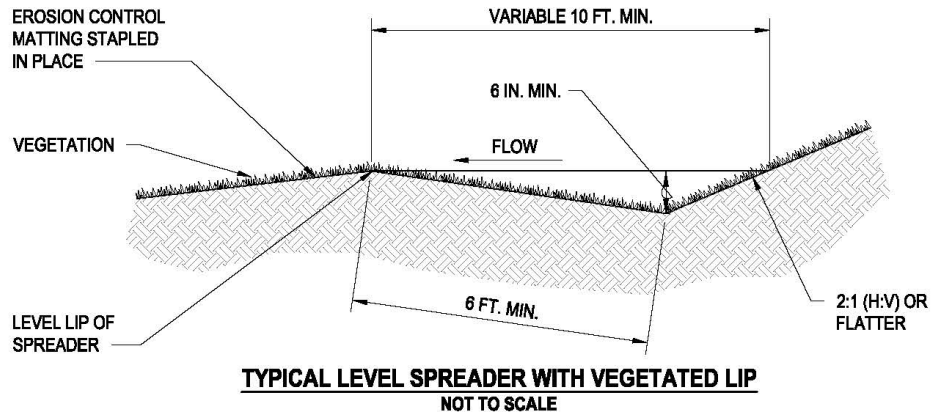



Description

Pipes to prevent erosion along slopes by intercepting and conveying runoff or groundwater from the top of the slope to a stabilized discharge point located at the bottom of the slope. Slope drains are primarily used to convey runoff down cut or fill slopes. Subsurface drains are primarily used to remove water from the soil in sloped areas.

Applications

- Use of slope drains is applicable to the following:
 - Drainage of concentrated runoff from within swales or behind dikes located at the top of slopes.
 - Drainage of surface runoff to prevent erosion along the slope.
- Emergency spillways for sediment basins.
- Use of subsurface drains is applicable to areas where water must be removed from the soil to lower the groundwater table or to prevent excessive soil saturation.

Installation and Implementation Requirements

SLOPE DRAIN DESIGN CONSIDERATIONS

- Consult with a hydrogeologist or qualified engineer regarding design flows.
- Limit drainage area discharging to slope drain to 5 acres.
- Direct surface runoff into slope drain using interceptor dikes at the top of slope. *See* section EC-5 Earth Dikes, Swales, and Ditches for more information.

Installation and Implementation Requirements *(continued)*

- Pipe slope drains exceeding 12 inches in diameter require a standard flared end section or headwall constructed at the inlet and outlet.
- Common materials used for slope drains is plastic lining, fiber matting, flexible plastic pipe, metal pipe, rigid pipe, and half round pipe.
- Install lining such as vegetation or geotextile filter fabric to protect area around inlet.
- Install rip-rap or other energy dissipation device at outlets.
- Place rip-rap so it extends to the maximum flow depth, or to a point where vegetation will be satisfactory to control erosion.
- Compact soil under and around inlet, outlet, and along the pipe.
- Slope drain must be installed on a slope gradient of 3% or greater.
- Slope drains may be installed above-ground or buried beneath the slope surface.
- Drains that are buried beneath the slope surface must have an earth dike, a minimum of 12 inches, on top of the pipe at the top of slope.
- Above-ground installation shall utilize pipe anchors to secure pipe to ground and be spaced a maximum of 10 feet apart.
- Align slope drain perpendicular to contours of slope. Generally, limit maximum slope to 2:1 (H:V). For slopes exceeding 2:1 (H:V), velocity dissipation is required at the pipe outlet.
- A half round pipe, fiber matting or plastic lining can be installed for shorter slopes that have a gradient flatter than 2:1 (H:V).
- Berms must remain relatively low and vegetated. Limit berm height to no more than 24 inches in height.
- The pipe should have a minimum diameter of 12 inches and should be equal over the entire length. Maximum pipe diameter is 24 inches due to height limitations of berms.
- Direct sediment-laden storm water to a sediment trap or sediment basin.



High flow velocities at the pipe outlet require the implementation of velocity dissipation devices to prevent downstream erosion.



Slope drains may be installed above-ground or buried beneath the slope surface.



Slope Drains and Subsurface Drains

Considerations

- Drainage area discharging to slope drains shall not exceed 5 acres. For larger areas, use multiple pipes, paved chute, or rock lined channel.
- Clogged slope drains direct runoff around pipe which may result in erosion along the slope.
- High flow velocities at the pipe outlet require implementation of velocity dissipation devices to prevent downstream erosion. *See* section EC-8 Outlet Protection and Velocity Dissipation Devices for more information.
- High flows may wash away velocity dissipation devices at the outlet, which leaves the area susceptible to erosion.
- Severe flooding and erosion may result from failure of slope drains and storm water overtopping the berm.

What to Inspect

- Are slope drains accumulating debris and sediment?
- Is there evidence of scour or erosion at the outlet?
- Is the pipe damaged or leaking?
- Are the pipe connections watertight?
- Is the pipe anchored to the slope?
- Is ponding occurring in active traffic lanes or material storage areas?

Maintenance

- Repair damage caused by erosion and scour, and install energy dissipation devices as necessary.
- Remove sediment and debris from entrances, outlet, and within drains to maintain flows.
- Repair/replace pipe if it is leaking or damaged.

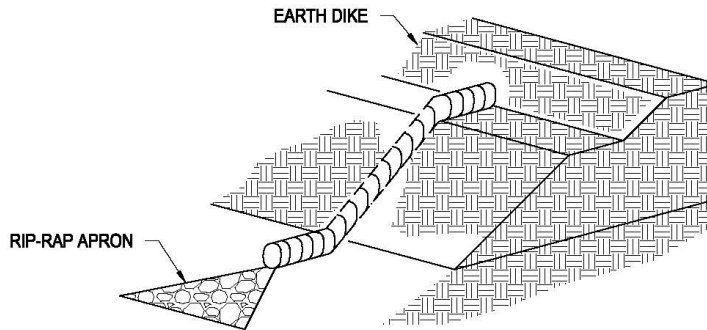

PERSPECTIVE
NOT TO SCALE

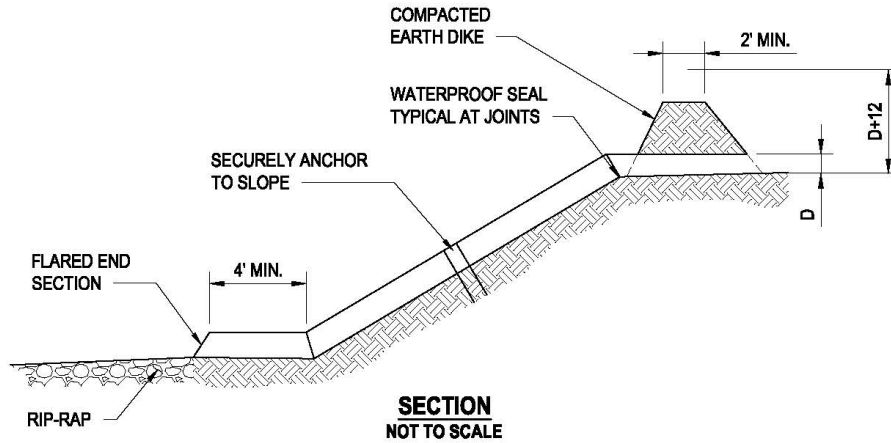

SECTION
NOT TO SCALE

NOTES:

1. INSTALL SLOPE DRAINS PERPENDICULAR TO SLOPE CONTOURS.
2. SLOPE DRAINS CAN BE PLACED ON OR BURIED UNDERNEATH THE SLOPE SURFACE.
3. COMPACT SOIL AROUND AND UNDER ENTRANCE, OUTLET, AND ALONG LENGTH OF PIPE.
4. SECURELY ANCHOR AND STABILIZE PIPE AND APPURTENANCES INTO SOIL.
5. CHECK TO ENSURE THAT PIPE CONNECTIONS ARE WATERTIGHT.
6. PROTECT AREA AROUND INLET WITH FILTER CLOTH.
7. TOP OF INTERCEPTOR DIKES SHOULD BE LIMITED TO 12" HIGHER THAN THE TOP OF THE SLOPE DRAIN.
8. MAXIMUM SLOPE IS GENERALLY LIMITED TO 2:1 (H:V).
9. DIRECT SURFACE RUNOFF TO SLOPE DRAINS WITH INTERCEPTOR DIKES.
10. PROTECT OUTLET OF SLOPE DRAINS USING FLARED END SECTION WHEN OUTLET DISCHARGES TO A FLEXIBLE ENERGY DISSIPATION DEVICE. THE FLARED SECTION SHOULD SLOPE TOWARDS THE PIPE INLET.

PIPE SLOPE DRAIN (RIGID)

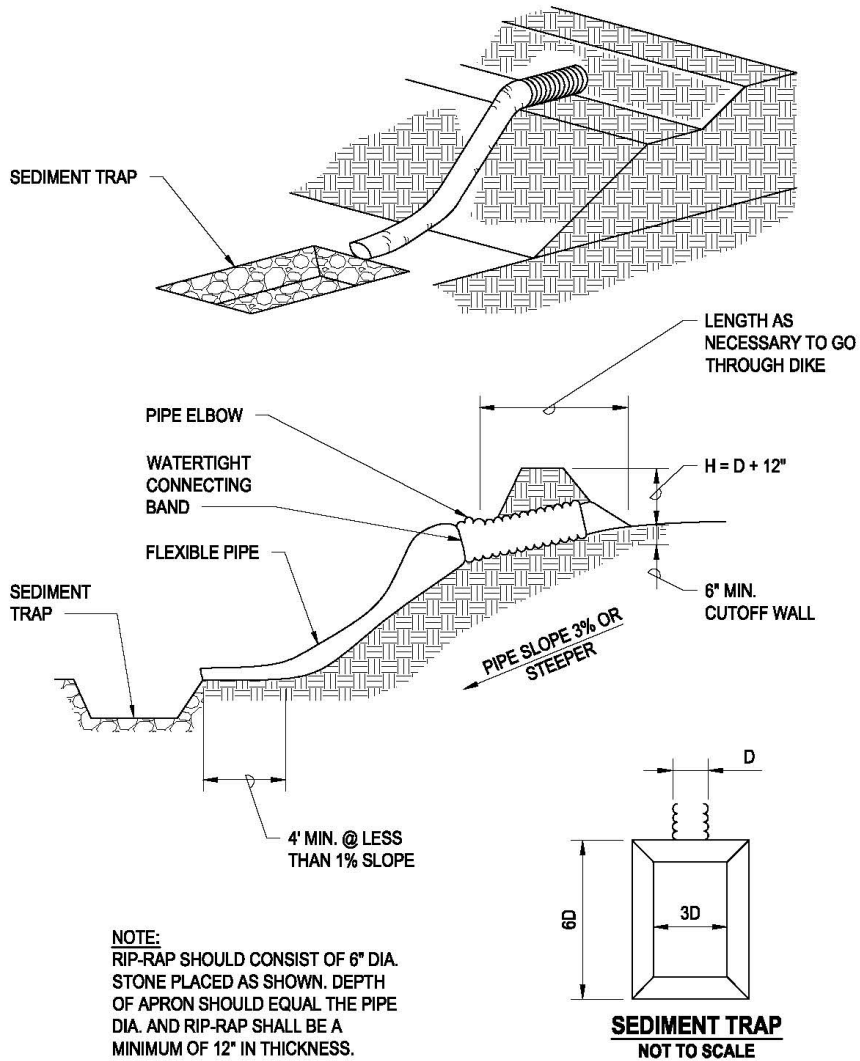

PIPE SLOPE DRAIN (FLEXIBLE)
NOT TO SCALE

Outlet Protection and Velocity Dissipation Devices



Description

Devices placed at outlets of pipes and channels to prevent or minimize scouring and erosion by reducing the velocity of storm water flow.

Applications

- Outlets with continuous flows.
- Outlets located at the bottom of slopes.
- Outlets subject to short, intense flows.
- Discharge points from lined conveyances to unlined conveyances.
- Inflow protection.
- Outlet protection that diverts runoff to a natural or manmade drainage element.
- In-stream/channel designed to prevent banks from erosion.

Installation and Implementation Requirements

- Apron length shall be determined by outlet flow rate and tailwater level.
- Align apron with direction of flow and avoid curves in apron. If a curve is necessary, place it in the upper section of the apron.
- Protect the underlying geotextile filter fabric with a 4-inch minimum rock blanket if the rip-rap is 12 inches or larger.
- Increase rock size to counteract high flow velocities.

Outlet Protection and Velocity Dissipation Devices

Installation and Implementation Requirements *(continued)*

- Place geotextile filter fabric between aggregate and the underlying soil to prevent soil movement.
- Outlets on slopes steeper than 10% must have additional protection.
- Place and extend rip-rap downstream until stable conditions are met.

Considerations

- Potential for stones to wash away during high velocity flows.
- Break up of grouted rip-rap can result from hydrostatic pressure caused by water accumulation.
- It is difficult to repair underlying geotextile filter fabric without removing rip-rap.
- Larger stones are prone to damaging the geotextile filter fabric during installation when installing with a machine and may require installing by hand.

What to Inspect

- Is there scour evident beneath the rip-rap and around the outlet?
- Is accumulated sediment wedged in-between rip-rap?
- Can illicit discharge be found in the outlet?
- Is the proper size rock being used?
- Is there damage to underlying geotextile filter fabric?

Maintenance

- Immediately repair damaged slopes or underlying geotextile filter fabric with priorities based on highway safety and protection of Class AA and Class 1 waters, followed by erosion potential and possible damage to downslope areas.
- Replace displaced rip-rap.
- Remove accumulated sediment in aggregate.



Remove accumulated sediment and replace displaced rip-rap as necessary to ensure effectiveness of BMP.

Outlet Protection and Velocity Dissipation Devices

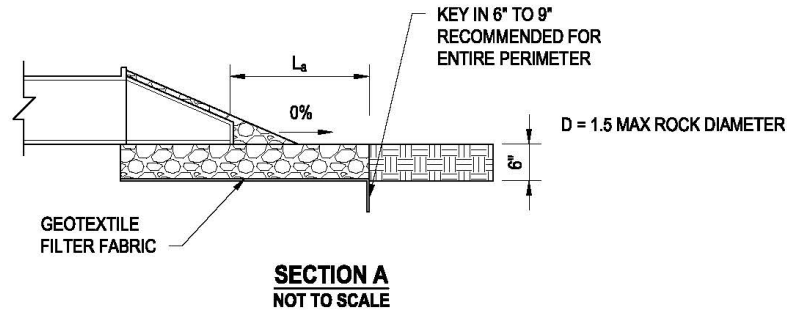
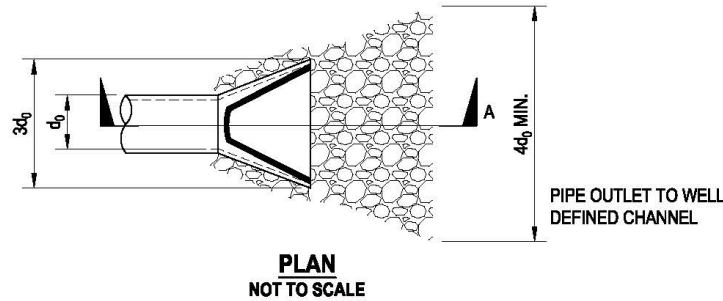

NOTES:

1. THE APRON LENGTH AND ROCK SIZE GRADATION ARE DETERMINED USING THE TABLE.
2. INSTALL RIP-RAP, GROUDED RIP-RAP, OR CONCRETE APRON AT SELECTED OUTLET. RIP-RAP APRONS ARE BEST SUITED FOR TEMPORARY USE DURING CONSTRUCTION. GROUDED OR WIRED TIED ROCK RIP-RAP CAN MINIMIZE MAINTENANCE REQUIREMENTS.
3. CAREFULLY PLACE RIP-RAP TO AVOID DAMAGING THE FILTER FABRIC.
 - a. STONE 4 IN. TO 6 IN. MAY BE CAREFULLY DUMPED ONTO FILTER FABRIC FROM A HEIGHT NOT TO EXCEED 12 IN.
 - b. STONE 8 IN. TO 12 IN. SHOULD BE HAND PLACED ONTO FILTER FABRIC, OR THE FILTER FABRIC MAY BE COVERED WITH 4 IN. OF GRAVEL AND THE 8 IN. TO 12 IN. ROCK MAY BE DUMPED FROM A HEIGHT NOT TO EXCEED 16 IN.
 - c. STONE GREATER THAN 12 IN. SHOULD ONLY BE DUMPED ONTO FILTER FABRIC PROTECTED WITH A LAYER OF GRAVEL WITH A THICKNESS EQUAL TO ONE HALF THE D50 ROCK SIZE, AND THE DUMP HEIGHT LIMITED TO TWICE THE DEPTH OF THE GRAVEL PROTECTION LAYER THICKNESS.
4. OUTLETS ON SLOPES STEEPER THAN 10 PERCENT SHOULD HAVE ADDITIONAL PROTECTION.

PIPE DIAMETER, (inches)	DISCHARGE (ft ³ /s)	APRON LENGTH, L _a (ft)	RIP-RAP D50 DIAMETER, MIN (inches)
12	5	10	4
	10	13	6
18	10	10	6
	20	16	8
	30	23	12
24	40	26	16
	30	16	8
	40	26	8
	50	26	12
	60	30	

FOR LARGER OR HIGHER FLOWS CONSULT A LICENSED CIVIL ENGINEER.
SOURCE: USDA-SCS

PIPE OUTLET CONDITIONS

Slope Interceptor or Diversion Ditches/Berms



Description

Methods to minimize sheet flow over slopes and reduce erosion by intercepting and conveying runoff to sediment removing structures or a protected drainage system.

Applications

- Protecting slopes from sheet flow runoff.
- Areas which must be protected from runoff flowing down slopes.
- Installed horizontally across disturbed slopes to reduce runoff velocity.
- Slopes where runoff must be intercepted at bottom of slope.
- Terraced areas on large/long slopes.
- Remove runoff to treatment area.
- A built-in ditch/swale at the base or top of the disturbed slope to divert storm water to an area where erosion control is prevalent.

Installation and Implementation Requirements

- Design flows and safety factors shall be determined by an evaluation of risks associated with erosion and overtopping, flow backups, or structure washouts. Consult with the District Maintenance Engineer or Highways Division's Hydraulic Section to determine these values.
- Ditches with high flow velocities shall be lined or stabilized. Consider use of rock check dams to slow flow.

Slope Interceptor or Diversion Ditches/Berms

Installation and Implementation Requirements *(continued)*

- Direct flows at top of slopes to slope drains or a sediment trap. *See* sections EC-7 Slope Drains and Subsurface Drains and SC-4 Sediment Trap for more information.
- A BMP device (dike, berm, compost filter sock) should be installed at the top of disturbed slopes until the slope is revegetated or temporary erosion control is installed on the face of the slope.
- Protect outlets from erosion.
- Place slope interceptors as follows:
 - Slope inclination of 4:1 (H:V) or flatter: Fiber rolls should be placed at a maximum interval of 20 feet.
 - Slope inclination between 4:1 and 2:1 (H:V): Fiber rolls should be placed at a maximum interval of 15 feet.
 - Slope inclination 2:1 (H:V) or greater: Fiber rolls should be placed at a maximum interval of 10 feet; a closer spacing is more effective.
- Stakes should be installed to secure compost filter berms. Drive stakes at least 12 inches into the ground. *See* section SC-6 Compost Filter Berm/Sock for more information.



Compost filter berms must be staked into the slope to secure them into the ground.

Considerations

- Additional sediment trapping BMP devices may be necessary for sediment-laden runoff.
- Slope interceptors on steeper slopes will need to be spaced closer due to faster flows.
- Slopes made up of a higher percentage of clay will increase the velocity of sheet flow.



Avoid using silt fences on slopes. However, if silt fence is placed on a slope, the fence post may need additional embedment.

Slope Interceptor or Diversion Ditches/Berms

What to Inspect

- Are washouts evident in ditches or berms?
- Are structures accumulating sediment and/or debris?
- Is there evidence of rill or gully erosion?
- Is sediment discharging into outlets?
- Are berms correctly trenched and staked?
- Are berms properly spaced on slope?
- Is a BMP device installed at the top of the disturbed slope?
- Are additional BMPs required to prevent erosion and undermining?



Compost filter berms that do not maintain direct contact with soil allows erosion and undermining to occur.

Maintenance

- Repair or replace rip-rap as needed.
- Repair damaged lining as needed.
- Use soil stabilizers.
- Compact fill berms and revegetate.
- Compact and revegetate ditches as needed.
- Remove accumulated sediment when it reaches one-half the height of the berm.
- Repair/replace compost filter berms that have rips and tears.



Description

Devices to protect soil surfaces from erosion by stabilizing slopes, and slowing the velocity of concentrated runoff.

Rip-rap is large, irregular shaped rocks that fit into place to provide erosion control and slow the velocity of concentrated runoff.

Gabions are wire baskets filled with rock, concrete, or other materials that lines drainageways to stabilize the flow channel along steep slopes, shorelines, and stream banks against erosion.

Applications

RIP-RAP

- Use of rip-rap inflow protection applies to slopes between 10:1 and 4:1 (H:V)
- Erosion-resistant ground cover
- Pipe outlet protection
- Channel lining
- Stabilized slopes
- Shoreline stabilization
- Dissipates high velocities or concentrations of storm water

Applications *(continued)*

GABIONS

- Use of gabion inflow protection applies to slopes exceeding 4:1 (H:V)
- Retaining structures
- Foundation construction e.g., dams
- Aesthetic purposes
- Rip-rap and gabions are relatively maintenance free and long lasting
- These devices can be used as a temporary or permanent BMP
- Temporary flood walls
- Shoreline stabilization
- Change direction of source water
- Energy dissipation device in channels

Installation and Implementation Requirements

RIP-RAP

- A licensed civil Engineer must provide a design and calculations for HDOT's approval prior to installation.
- 2:1 (H:V) side slopes, 3-foot minimum bottom width, and 1-foot minimum depth.
- Line channel with 4- to 12-inch rip-rap at a depth of 18 inches. The larger stones must be predominant, while the smaller stones fill the voids.
- Install geotextile filter fabric under all rip-rap to separate rocks with underlying soil. Prior to placing geotextile filter fabric, provide a 3-day notice to the Engineer for inspection of foundation.
- Blend rip-rap into existing ground at uniform thickness so the stream width is not radically narrowed.
- Stones shall be clean, sound, durable, and angular in shape, resistant to weathering and water action, and free from organic material. Stones shall be shaped so that neither their breadth nor thickness are less than one-third their length, not rounded, and have minimum unit weight of 155 pounds per cubic foot. Refer to *2005 Hawaii Standard Specifications for Road and Bridge Construction*, Standard Specifications & Special Provisions Section 655.



Rip-rap can help prevent or minimize erosion when used to stabilize shorelines.

Installation and Implementation Requirements *(continued)*

GABIONS

- A licensed Civil Engineer must provide a design and calculations for HDOT's approval prior to installation.
- Gabion inflow may be used in lieu of rip-rap inflow protection.
- Gabions are prefabricated wire baskets filled with a well-graded mixture of aggregate. The larger stone must be predominant, while the smaller stones fill the voids.
- Baskets must be made of hexagonal triple twist mesh with heavily galvanized steel wire.
- Construct 2:1 (H:V) side slopes, 3-foot bottom width, and 1-foot deep from 9-foot × 3-foot × 1-foot gabion baskets. Install geotextile filter fabric under all gabion baskets.
- A bedding layer of aggregate can be placed before the gabion baskets are installed to level the surface and maximize stability.
- Fill gabion baskets with 4- to 7-inch clean (no fines) stone.
- Hand place rocks in gabion baskets to minimize voids and/or bulges. Rock edges must not poke through the gabion basket. Install gabions in accordance with manufacturer's recommendations.
- The wire mesh of the gabion basket will eventually fail due to corrosion. The designer must consider this and plan for overall stability when the basket fails.



Gabions must be filled with a well graded mixture of aggregate, with larger stones being predominant and smaller stones to fill the voids.

Considerations

- Gabion installation is labor intensive (hand installation).
- Costly compared to vegetative devices.
- Not always aesthetically pleasing.
- Scour tends to occur at toe and end of rip-rap.
- If gabions or rip-rap is used within a U.S. Army Corps of Engineers (USACE) jurisdictional waterbody that coordination with the USACE is required.

What to Inspect

- Is there evidence of scour around rip-rap or gabions?
- Has debris and/or sediment accumulated around or in rip-rap?

What to Inspect *(continued)*

- Has an underlying filter fabric/geotextile been installed?
- Has the BMP device been installed correctly?
- Are rocks displaced?
- Does the gabion structure show signs of bulging or gaps?
- Is there damage to the gabion basket?
- Is there evidence of rock failure?
- Does the BMP need to be cleaned out or replaced?

Maintenance

- Remove accumulated sediment lodged between rip-rap that is affecting filtration purposes.
- Replace/refresh rocks that have been displaced.
- Repair damage to filter fabric/geotextile under rip-rap.
- Any evident damage or abnormalities to the gabion must be repaired.



If rip-rap is displaced by storm water during a large rain event, refresh the channel with 4- to 12-inch rip-rap.

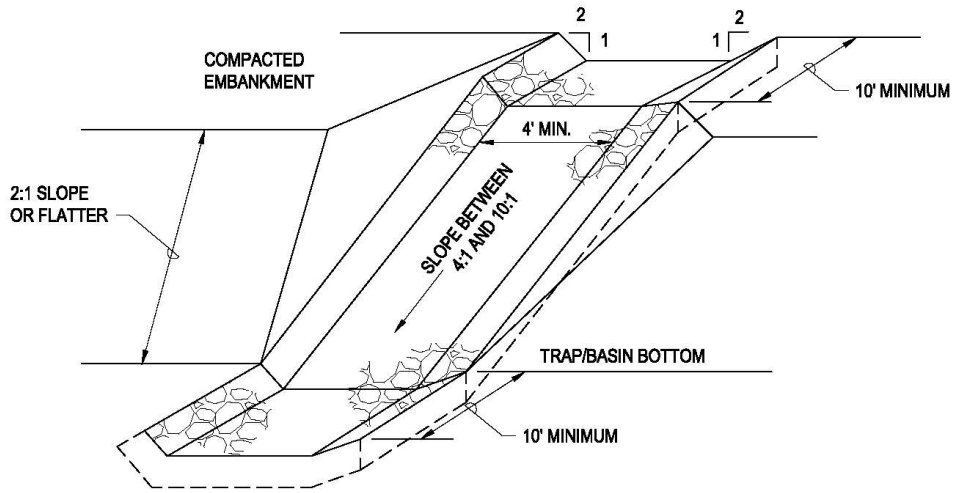

PERSPECTIVE
NOT TO SCALE

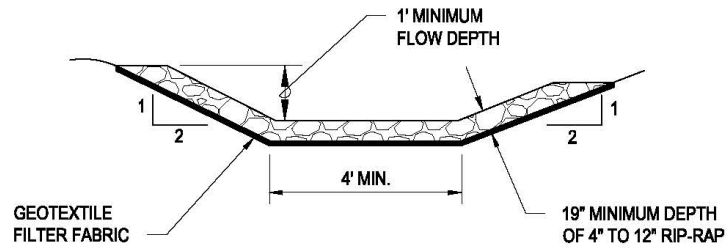

CROSS SECTION
NOT TO SCALE

RIP-RAP INFLOW PROTECTION

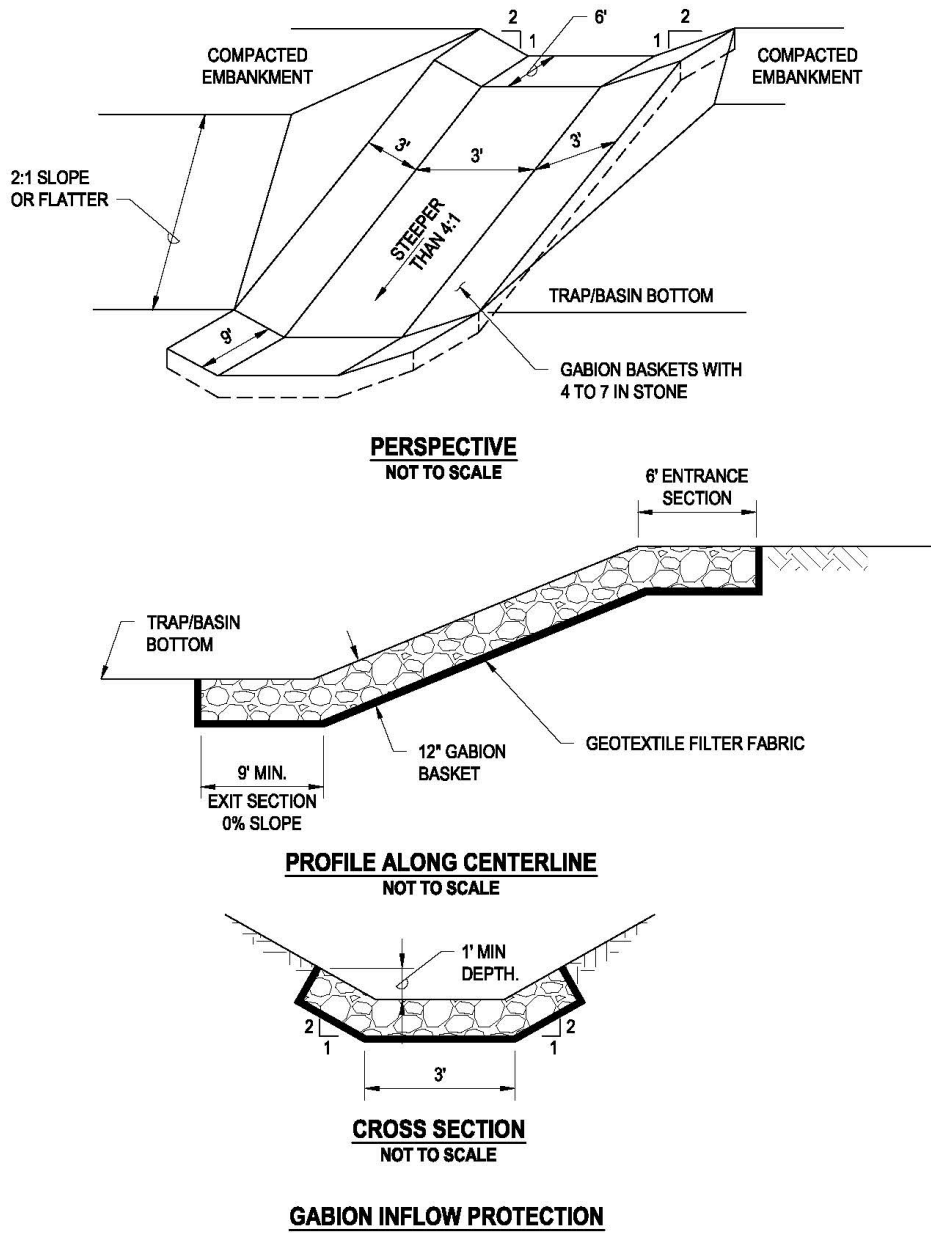



Description

Natural or synthetic mats are roll-type materials used for temporary or permanent soil stabilization and protection from rain/wind erosion.

Applications

- Stabilize drainage ditches, channels, and stream banks.
- Stabilize steep slopes with high potential for erosion.
- Stabilize slope until vegetation is established.
- Hold water near surface to assist in vegetation growth.
- Protect stockpiles from wind erosion.
- Suppress weed growth.
- Provide temporary cover for bare areas that are idle.

Installation and Implementation Requirements

- Apply matting to disturbed soils and areas where vegetation has been removed.
- Install matting immediately after the area is seeded and fertilized.
- Minimize disturbance of slopes greater than 15% in grade.
- Phase disturbances and use stabilization techniques designed for steep grades if disturbance of steep slopes is unavoidable.

Installation and Implementation Requirements *(continued)*

- Grade and shape disturbed slopes prior to installing geotextiles and/or erosion control matting.
- Prepare area by removing rocks, vegetation and other obstructions that will inhibit direct contact with soil.
- Entrench or anchor material at the top and bottom of the slope in a 6-inch × 6-inch trench or per manufacturer’s specifications, whichever is more stringent. The trench should be placed a minimum of 12 inches from the top of the slope.
- Intermittent check slots can also be installed for large or long lengths of matted areas to increase stability of the area.
- Do not stretch matting. Maximize mat contact with soil by loosely laying blankets and securing to slope with stakes.
- Ensure matting maintains direct contact with soil to prevent rills, gullies, and undermining.
- Follow manufacturer’s specifications on overlapping and stake spacing requirements. Steep slopes may require additional staking requirements.
- If geotextile matting is to be installed on steep slopes greater than 15%, space stakes every 2 feet.
- Organic matting provides temporary protection until permanent vegetation has been established or construction activities recommence. Organic matting materials include the following:
 - Jute matting
 - Straw matting
- Synthetic matting provides temporary or post-construction soil stabilization in both vegetated and non-vegetated areas. Synthetic matting materials include the following:
 - Excelsior™ matting
 - Glass fiber matting
 - Stakes
 - Mulch netting
 - Plastic sheeting/covering



Check with manufacturer’s specifications for erosion control matting anchorage requirements.

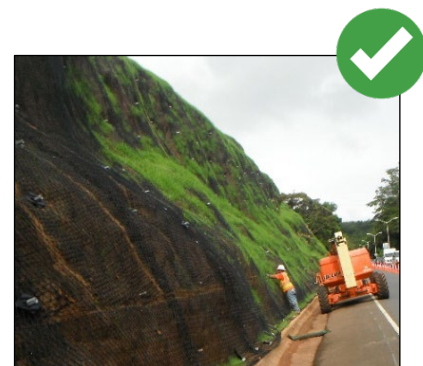

Phase disturbances and use stabilization techniques designed for steep grades if disturbance of steep slopes is unavoidable.

Installation and Implementation Requirements *(continued)*

- Key in temporary plastic sheeting at top of slope and weigh down by gravel bags no more than 6 feet apart.
- Install erosion control measures or devices at the top and toe of the slope to filter sediment-laden runoff and decrease storm water velocity.
- Other proprietary devices may be used and shall be installed per manufacturer's recommendations.
- The contractor shall immediately initiate soil stabilization measures when earth-disturbing construction activities on exposed areas have been completed or will be temporarily inactive for 14 or more calendar days.

Considerations

- Minimize use of matting to areas where other erosion control measures are not applicable such as channels or steep slopes since matting is costly compared to other erosion control measures.
- Seed germination may be delayed due to decreased soil temperature.
- Extensive soil preparation is needed before installation for adequate contact with slope.
- Mats made of natural material have a limited life and low shear strength.
- High material cost and extensive manpower needed.
- Generally, the slope needs to be smooth and free of large rocks.
- Plastic sheeting results in 100% runoff and is easily torn/damaged.

What to Inspect

- Is there evidence of undercutting at the top of slope?
- Is the slope eroding beneath the blanket?
- Are blankets firmly anchored and trenched in at top and bottom of slope?
- Are blanket segments properly overlapped?
- Are stakes properly spaced and driven into the soil to prevent the blanket from lifting away from soil?
- Is matting free from any defects or tears?
- Are there areas not adequately growing vegetation?



Matting must maintain direct contact with soil to prevent rills, gullies, and undermining.



Geotextiles and Mats

Maintenance

- Repair undermining or erosion.
- Repair/replace damaged blankets.
- Replace stakes and sandbags as needed.
- Reseed and fertilize areas not adequately growing vegetation.

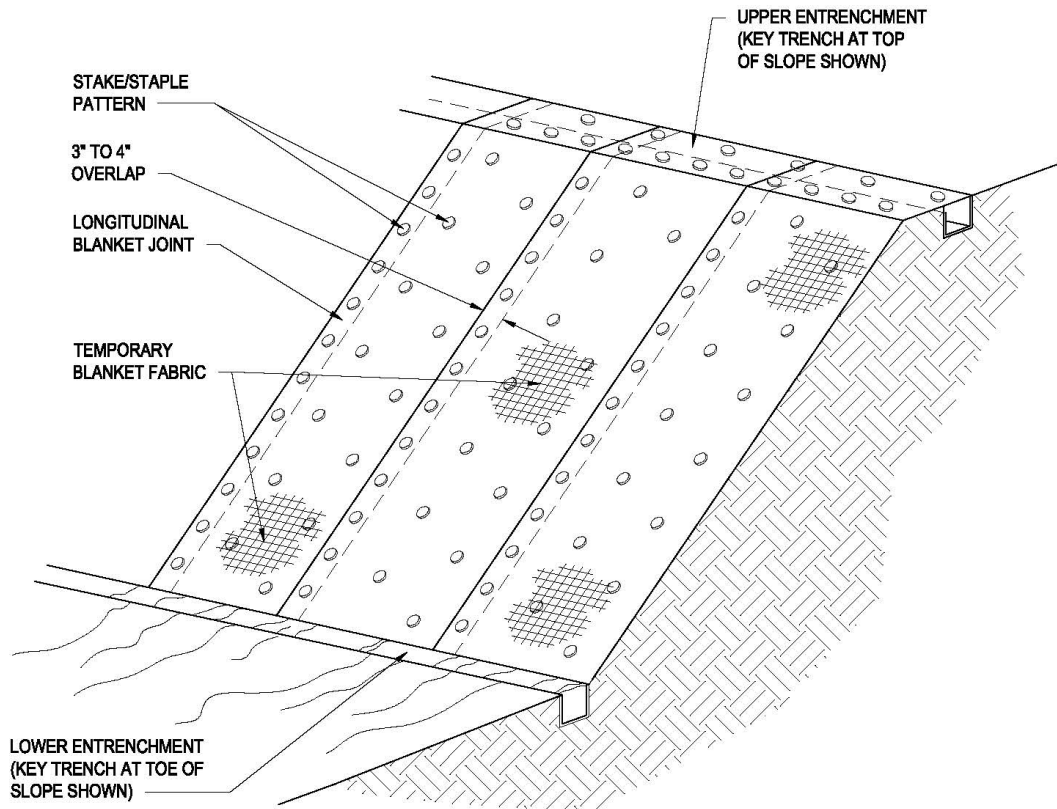

TEMPORARY EROSION CONTROL BLANKET ON SLOPE
NOT TO SCALE

NOTES:

1. SLOPE SURFACE SHALL BE FREE OF ROCKS, CLODS, STICKS, AND GRASS. SOIL CONTACT SHALL BE MAXIMIZED.
2. LAY BLANKETS LOOSELY AND STAKE TO MAINTAIN DIRECT CONTACT WITH THE SOIL. DO NOT STRETCH.
3. INSTALLATION MAY VARY ACCORDING TO MANUFACTURER'S RECOMMENDATIONS. APPLY THE MORE STRINGENT REQUIREMENT.

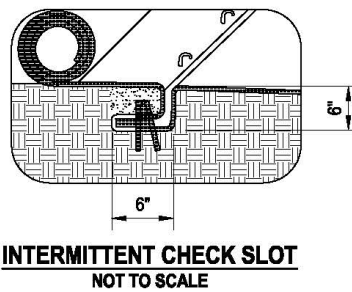
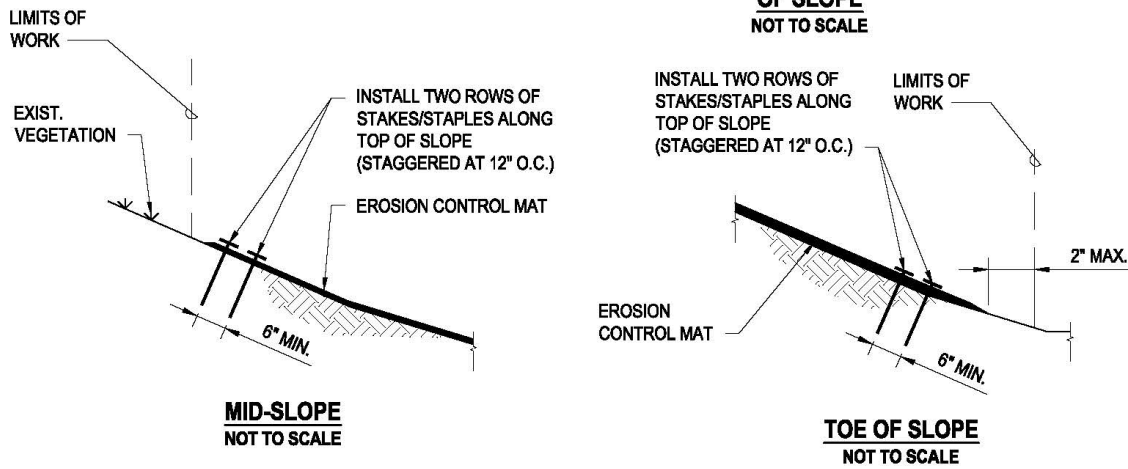
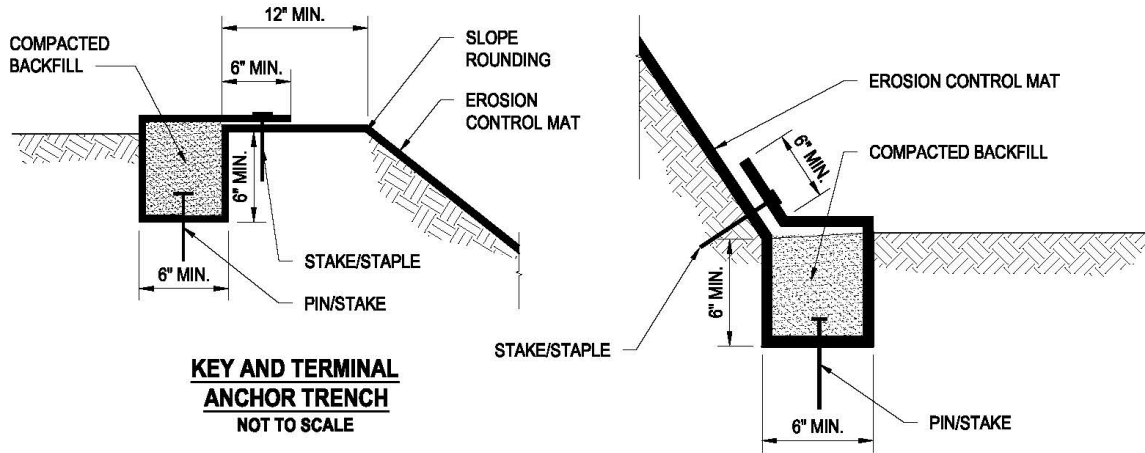

**GEOTEXTILES AND MATS INSTALLATION
DETAIL FOR SLOPES**

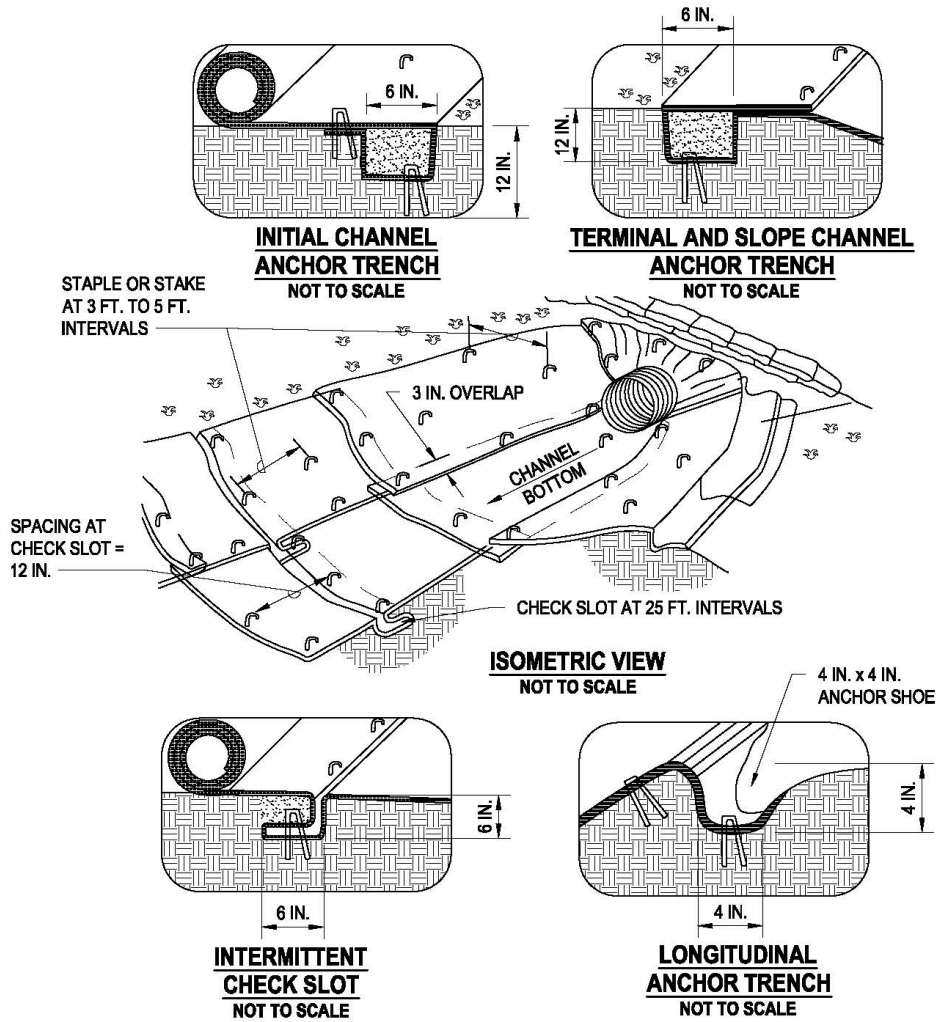

GEOTEXTILES AND MATS DETAIL FOR CHANNELS

NOTES:

1. CHECK SLOTS TO BE CONSTRUCTED PER MANUFACTURER'S SPECIFICATIONS.
2. STAKING OR STAPLING LAYOUT PER MANUFACTURER'S SPECIFICATIONS.



Description

Practices and procedures to provide ground cover for temporary or permanent stabilization of soil.

Applications

Soil stabilization during or after the construction phase applies to the following site conditions:

- Graded/cleared areas upon temporary or permanent cessation of earth-disturbing activities
- Open space and fill areas
- Steep slopes
- Spoil piles or temporary stockpile of fill material
- Vegetated swales
- Landscape corridors
- Stream banks

Installation and Implementation Requirements

- Coordinate temporary vegetative stabilization with permanent vegetative stabilization.
- Restrict vehicle/equipment use in areas where vegetative stabilization will be used to avoid soil compaction.

Installation and Implementation Requirements *(continued)*

- A licensed landscape architect should review the proposed vegetation to be used for the project.
- Condition the soil to promote vegetative growth prior to planting in areas where vehicle/equipment use cannot be avoided.
- Contractor shall keep records of application dates, type(s), amount of fertilizer used, and the areas covered.
- Plant vegetation immediately after Engineer approval.
- Minimize the amount of exposed soil during construction activity by phasing disturbances.
- Preserve native topsoil and vegetation where practicable.
- Use of invasive species is prohibited.

SEEDING AND PLANTING APPLICATION CONSIDERATIONS

- Type of vegetation
- Site and seedbed preparation
- Seasonal planting times
- Fertilizers
- Water

GRASSES

- Ground preparation requires fertilization, scarification, and mechanical stabilization of the soil.
- Can tolerate short-term temperature extremes and waterlogged soil conditions.
- Appropriate soil conditions include a shallow soil base, good drainage, and 2:1 (H:V) or flatter slope.
- Quickly develops from seeds.
- Vigorous grass growth depended on mowing, irrigating, and fertilizing.
- Immediately after seeding or planting the area to be vegetatively stabilized, to the extent necessary to prevent erosion on the seeded or planted area, install non-vegetative erosion controls that provide cover (e.g., mulch, rolled erosion control products) to the area while vegetation is becoming established.

TREES AND SHRUBS

- Selection dependent on vigor, species, size, shape, and potential wildlife food source.
- Consider wind/exposure and irrigation requirements.
- Plant indigenous species where possible.

Installation and Implementation Requirements *(continued)*

VINES AND GROUND COVER

- Lime and fertilizer required for ground preparation.
- Use appropriate seeding rates.
- Consider requirements for drainage, acidity, and ground slope.
- Plant indigenous species where possible.
- Avoid species that require irrigation.

FERTILIZER USE

- Do not apply fertilizers or pesticides during or just before a rain event.
- Do not apply to storm water conveyance channels with flowing water.
- Comply with fertilizer and pesticide manufacturer's recommended usage and disposal instructions. Do not over apply.
- Apply fertilizers at the appropriate time of year for the location, and preferably as closely as possible to the period of maximum vegetation uptake and growth.
- Where possible, till fertilizer into soil rather than surface spreading or spraying on steep slopes.
- Minimize discharges of fertilizers containing nitrogen or phosphorus.
- Store fertilizer in original container with proper labeling, sealed, and under cover or covered with secondary containment.
- Follow federal, state, and local laws regarding fertilizer application.

WATERING

- Quantity and frequency of watering may vary depending on type of vegetation, type of soil, location, frequency of rainfall, and slope.
- Regulate quantity of water to prevent erosion and formation of gullies.
- Temporary irrigation may be required for initial establishment of vegetation and sustained growth.
- Permanent water supply source may be required for certain types of vegetation.



Temporary irrigation may be required for initial establishment of vegetation and sustained growth.

STABILIZATION

- Initiate soil stabilization measures immediately whenever earth-disturbing activities have permanently or will/has temporarily ceased for 14 or more calendar days on any portion of the site to prevent erosion.

Installation and Implementation Requirements *(continued)*

- Types of activities that constitute initiation of stabilization include the following:
 - Prepping the soil for vegetative or non-vegetative stabilization.
 - Applying mulch or other non-vegetative product to the exposed area.
 - Seeding or planting the exposed area.
 - Starting any activities listed above on a portion of the area to be stabilized, but not on the entire area.
 - Finalizing arrangements to have stabilization product fully installed in compliance with the deadline for completing initial stabilization activities.
- Stabilization activities must be completed as soon as practicable, but no later than 14 days after the initiation of soil stabilization measures. If area drains to impaired waters, stabilization activities must be completed as soon as practicable, but no later than 7 days after the initiation of soil stabilization measures. Refer to the Hawaii Administrative Rules (HAR) Title 11, Chapter 55, Appendix C for more information.
- Types of activities that constitute completion of initial stabilization activities include the following:
 - For vegetative stabilization, all activities necessary to initially seed or plant the area to be stabilized.
 - For non-vegetative stabilization, the installation or application of all such non-vegetative measures.
- Vegetative coverage must be perennial.
- Establish uniform vegetation, which provides 70% of coverage that was provided by vegetation prior to commencing earth-disturbing activities.
- The contractor should take pictures of the area being used prior to installing BMPs. This will provide evidence of the amount of vegetation in the area prior to commencing earth-disturbing activities.
- Immediately after seeding the area the contractor shall install non-vegetative erosion controls, to the extent necessary, to provide cover to the area while vegetation is becoming established.
- Install perimeter controls around exposed areas where vegetation is becoming established to prevent sediment-laden runoff from entering storm drain systems and open waterbodies.
- Remove non-vegetative erosion controls once the area is deemed stabilized by the Engineer.



Install non-vegetative erosion controls, to the extent necessary, to provide cover to areas where vegetation is becoming established.

Considerations

- During dry periods without irrigation, permanent and temporary vegetation may not grow.
- Improper application of fertilizer may contribute to storm water pollution.
- Vegetative coverage must be perennial for final stabilization.
- Lack of dedicated water supply may require a temporary water source.
- Rainwater can wash away seeds and fertilizer from areas being restabilized.
- It is common for topsoil to be lost from grading, which causes the soil to lack nutrients for seeds to germinate.
- Disturbed areas may be difficult to stabilize if soil has been compacted.

What to Inspect

- Is vegetation growing?
- Is there evidence of erosion?
- Are fertilizers being properly stored and handled?
- Are fertilizers being over applied or applied in an improper area?
- Is there at least 70% vegetative coverage?
- Are temporary non-vegetative stabilization devices installed?
- Has soil been conditioned?
- Are native plants being used?
- Has the contractor initiated vegetative stabilization within the required timeframe?

Maintenance

- Water, fertilize, mow, weed, and/or prune the grasses/plants as needed.
- Repair broken or leaking water lines, sprinklers, or valves used for irrigation.
- Mow temporary plantings as needed to prevent signage/site obstructions, fire hazards, or nuisances to the public.
- Replace plants that fail to develop healthy growth, become injured, or die.
- Remove invasive species.
- Reseed areas where the grass did not grow and/or any areas affected by erosion.



Description

Application of a mixture of wood fiber, seed, fertilizer, and stabilizing emulsion with hydromulch equipment to temporarily protect exposed soils from wind and water erosion.

Applications

- Temporary ground cover until permanent vegetation has been established.
- Suitable for disturbed areas that will be redisturbed following an extended period of inactivity.

Installation and Implementation Requirements

- Seed type must be carefully selected based upon anticipated soil type and future irrigation. All seeds must be in conformance with the State of Hawaii Department of Agriculture (HDOA). For information on appropriate seed mixes, visit the Hawaii office of the United States Department of Agriculture, Natural Resources Conservation Service (NRCS) website.
- Avoid use of hydroseeding in areas where future earthwork activities will commence.



Apply hydroseed to moderate soil moisture and temperature until seeds germinate and grow.

Installation and Implementation Requirements *(continued)*

- Roughen the slope, fill area, or area to be seeded with the furrow trending along the contours prior to application of hydroseed. Rolling with a crimping or punching type roller or track walking is required on all slopes prior to hydroseeding. *See* EC-4 Slope Roughening, Terracing, and Rounding for more information.
- Apply mulch to keep seeds in place and to moderate soil moisture and temperature until the seeds germinate and grow.
- Avoid spraying hydroseed onto sidewalks, lined drainage channels, roads, and existing vegetation.

EVALUATION OF SITE CONDITIONS CONSIDERATIONS TO SELECT APPROPRIATE HYDROSEEDING MIXTURES

- Soil conditions
- Site topography
- Season and climate
- Vegetation types
- Maintenance requirements
- Sensitive adjacent areas
- Water availability
- Plans for permanent vegetation

Considerations

- Steep slopes are difficult to protect with temporary seeding.
- Hydroseeding shall only be used when there is sufficient time to ensure adequate vegetation establishment and provide adequate erosion control.
- Temporary seeding may not be appropriate without supplemental irrigation.
- Temporary vegetation may have to be removed before permanent vegetation is applied.
- Hydroseeding shall not be used in areas subject to heavy traffic.
- To ensure complete coverage over roughen terrain, hydroseeding may have to be applied from multiple angles and sides.

What to Inspect

- Is there evidence of erosion?
- Are there bare areas that need to be reseeded?
- Is an irrigation system installed?
- Does the irrigation system apply complete coverage to the desired areas?
- Is the irrigation system working?
- Are there any areas of exposed soil showing?

Maintenance

- Mulches applied to seeded areas may be disturbed due to wind or runoff. Recover exposed areas until permanent vegetation has been established.
- Replace ornamental and landscape mulches of bark or wood chips if soil is visible in more than 75% of the designated area.
- Follow-up applications must be made as needed to cover weak spots and to maintain adequate soil protection.
- If erosion has occurred, additional mulch may be required. Eroded areas need to be repaired prior to additional mulch being added.



Additional mulch may be needed if erosion of hydroseeded area has occurred.



Description

Application of loose bulk material to stabilize disturbed soil by protecting bare soil, increasing infiltration, and reducing runoff. Materials suitable for mulching include green material, vegetable fibers (hay or straw), and wood/bark chips.

Applications

- Temporary ground cover until permanent vegetation has been established.
- Method may be used in combination with temporary or permanent seeding to enhance plant growth.
- Areas requiring soil moisture retention to prevent cracking of the soil.
- Ground cover for exposed soil between trees or shrubs.
- Mulch should be used in conjunction with other BMPs for optimal erosion control, especially on slopes.

Installation and Implementation Requirements

VEGETABLE FIBERS (HAY OR STRAW)

- Loose hay or straw which may be used in combination with seeding. Mulching usually follows seeding and the process is described in the following:
 - Apply seed and fertilizer to bare soil.
 - Apply loose hay or straw over top of seed and fertilizer prior to seed germination. Apply at a rate of 2,000 pounds per acre by machine or hand distribution.
 - Evenly distribute mulch on the soil surface to cover 80% to 90% of the ground.

Installation and Implementation Requirements *(continued)*

- Maintain maximum fiber length. Average fiber length shall be greater than 6 inches.
- Use a tackifier, netting, or mechanical “punching” method to anchor mulch. “Punching” refers to the act of crimping or compressing to anchor to the ground. Methods depends on slope steepness, accessibility, soil conditions, and longevity.
- Punching straw or hay to anchor the mulch to the ground is the preferred method of anchoring mulch for the following conditions:
 - Use a spade or shovel on small areas.
 - Use a knife-blade roller or straight bladed coulter (“crimper”) on slopes with soil, which can support construction equipment without undesirable compaction or instability.
 - Use plastic netting or jute on small areas and/or steep slopes. Geotextile pins, wooden stakes, or 11-gauge wire staples shall secure netting in place. This condition warrants consideration of the use of matting rather than mulch.
 - Use tackifiers on steep slopes unable to support construction equipment or large application areas where use of nettings, straw, or hay is not cost-effective. Tackifiers glue vegetable fibers together and to the soil surface until the establishment of permanent vegetation.



Use a tackifier, netting, or mechanical “punching” method to anchor mulch. Method depends on slope steepness, accessibility, soil conditions, and longevity.

GREEN MATERIAL

- Consists of recycled vegetation trimming such as grass and shredded shrubs and trees.
- Generally applied manually.
- Temporary ground cover with or without seedings.
- Evenly distribute green material on soil surface. Depth shall not exceed 4 inches.
- Anchor with a tackifier or netting on steep slopes or for areas with anticipated overland sheet flow. The condition warrants consideration of the use of matting rather than mulch.



Evenly distribute wood/bark chips on soil surface and maintain a 2-inch mulch depth to tree basins and a 4-inch mulch depth to shrub beds.

WOOD/BARK CHIPS

- Suitable for areas which will not be mowed such as around trees, shrubs, and landscape plantings.

Installation and Implementation Requirements *(continued)*

- Test soils prior to application. Add a minimum of 12 pounds of nitrogen per ton of mulch to counteract the effect of decomposing wood-based materials, which extract nitrogen from soil. Use a balanced, slow-release fertilizer or an organic source such as compost.
- Apply mulch manually.
- Evenly distribute wood/bark chips on soil surface and maintain a 2-inch mulch depth to tree basins and a 4-inch mulch depth to shrub beds.

Considerations

VEGETABLE FIBERS (HAY OR STRAW)

- Requires 3-step machinery.
- Labor intensive installation.
- For applications using straw blowers, the applicable area must be located within 150 feet of a road or surface capable of supporting loads from large vehicles. Use of straw is preferred, in lieu of hay, if available.
- Avoid applying fibers prior to an anticipated rain event.

GREEN MATERIAL

- Limited commercial availability.
- Variable quality.
- Application primarily uses manual labor.
- Unpredictable effectiveness as an erosion control measure. Requires overspray with a tackifying agent to increase effectiveness.
- Application of fertilizer may be required.
- Limit use to non-critical steep slopes and areas where alternative erosion control measures may be readily applied. A critical slope surface exists when a combination of soil and slope factors create a high potential for slope face failure and subsequent erosion, such as a slope greater than 2:1 (H:V) on freshly graded or disturbed slopes. Refer to *Slope Face Stabilization for Critical Slope Surfaces* at website – www.ccriindia.org/pdf/Object335PDFEnglish.pdf for more information on critical slopes.

WOOD/BARK CHIPS

- Poor erosion control effectiveness.

Considerations *(continued)*

- Anchoring of chips onto steep slopes is difficult due to potential movement from high winds.
- Subject to displacement from concentrated flows.
- Use of fertilizer with a high nitrogen content is required. This is to prevent nutrient deficiency in plants due to the decomposing wood-based materials, which extract nitrogen from soil. Improper fertilizer use may contribute to water quality pollution.
- Limit use to non-critical steep slopes and areas where alternative erosion control measures may be readily applied.

What to Inspect

- Is mulch applied to areas which will be regraded and/or revegetated?
- Is there uniform coverage of mulch?
- Was the application rate sufficient for the area?
- Is there evidence of rills or gullies?

Maintenance

- Mulches applied to seeded areas may be disturbed due to wind or runoff. Recover exposed areas until permanent vegetation has been established.
- Replace ornamental and landscape mulches of bark or wood chips if soil is visible in more than 75% of the designated area.
- If erosion has occurred, additional mulch may be required.



Description

Application of loose bulk material to stabilize disturbed soil by protecting bare soil, increasing infiltration, and reducing runoff. Materials used for mulching include hydraulic matrices, hydraulic mulches of recycled paper or wood fiber.

Applications

- Temporary ground cover until permanent vegetation has been established.
- Method used in combination with temporary or permanent seeding to enhance plant growth.
- Areas requiring soil moisture retention to prevent cracking of the soil.
- Ground cover for exposed soil between trees or shrubs.
- Mulch should be used in conjunction with other BMPs for optimal erosion control, especially on slopes.

Installation and Implementation Requirements

HYDRAULIC MULCHES OF RECYCLED PAPER

- Consists of recycled newsprint, magazines, and other wastepaper sources.
- May be applied with or without tackifiers.
- Hydraulic mulch materials shall conform to *2005 Hawaii Standard Specifications for Road and Bridge Construction*, Standard Specifications & Special Provisions Sections 209, 619 & 641, as in effect.

Installation and Implementation Requirements *(continued)*

- Mix mulch in a hydraulic application machine (hydroseeder) and apply as a liquid slurry.
- May be sprayed from a cannon up to 200 feet or from a hose up to 1,500 feet away from the application area.
- Mix mulch with seed and fertilizer as specified by the manufacturer. Apply mulch at the manufacturer's recommended rate to ensure uniform and effective coverage.
- Mulch used as temporary ground cover shall be reapplied to bare areas until permanent vegetation has been established.
 - Avoid spraying mulch onto sidewalks, lined drainage channels (i.e., concrete swales and concrete culverts), travelway areas, and existing vegetation.



Mulches must be applied at the manufacturer's recommended rate to ensure uniform and effective coverage.

HYDRAULIC MULCHES OF WOOD FIBER:

- Consists of wood waste from lumber mills or urban sources.
- May be manufactured with or without a tackifier.
- Hydraulic mulch shall conform to *2005 Hawaii Standard Specifications for Road and Bridge Construction*, Standard Specifications & Special Provisions Sections 209, 619, & 641, as in effect. Mix mulch in a hydraulic application machine (hydroseeder) and apply as a liquid slurry.
- Mix mulch with seed and fertilizer as specified by the manufacturer.
- Apply mulch at the manufacturer's recommended rate to ensure uniform and complete coverage.

HYDRAULIC MATRICES

- Hydraulic slurries consisting of wood fiber, paper fiber, or a combination of wood and paper fiber mixed with a binder system.
- Exceeds erosion control performance of blankets due to close contact with soil.
- Apply as an aqueous slurry (with seed) using standard hydroseeding equipment.
- Applications rates vary for different combinations of conditions and products.



Properly applied hydraulic mulches stabilize disturbed soil by protecting bare soil, increasing infiltration, and decreasing runoff.

Installation and Implementation Requirements *(continued)*

BONDED FIBER MATRIX (BFM) CONSISTING OF PREMIXED FIBER AND BINDERS

- After application and upon drying, BFM shall adhere to soil and form a 100% cover. The cover shall be biodegradable, promote vegetation, and prevent soil erosion.
- Are composed of long strand, thermally produced wood fibers (>88% of total volume by weight), held together by organic tackifiers (10%) and mineral bonding agents (<2%), which become insoluble and non-dispersible upon drying. Composition of BFM varies based on supplier.
- Perform a free liquid quality control test on the liquid slurry.
- Binder shall not dissolve or disperse upon watering.
- Upon applications to the soil, holes in the matrix shall not exceed 0.04 inches in size.
- There shall not be any gaps between the matrix and the soil.
- Minimum water holding capacity of the matrix shall be 1.2 gallons per pound matrix.
- The matrix shall be free of germination of growth inhibiting factors and shall not form a water-resistant crust.
- Materials used for the matrix shall be 100% biodegradable and 100% beneficial to plant growth.
- Testing and evaluation of the matrix by an independent research laboratory shall have been conducted to verify reported erosion control performance.
- A trained and manufacturer certified applicator with knowledge of proper mixing and product application shall install the BFM.

- Typical BFM application rates range from 3,000 to 8,000 pounds per acre per recommendations from various manufacturers.
- BFM shall not be applied 24 hours before an anticipated rain event, during a rainfall event, or immediately after a rainfall event to ensure a drying time of 24 hours after installation.

Considerations

HYDRAULIC MULCHES OF RECYCLED PAPER

- Limited erosion control effectiveness due to short fiber length and absence of a tackifier.
- Limited moisture and soil temperature moderation.
- Residual inks within mulches may be undesirable in environmentally sensitive areas.
- Significant decrease in longevity compared with wood fiber mulch.
- Difficulty budgeting for this product due to volatile prices for recycled paper products.

Considerations *(continued)*

HYDRAULIC MULCHES OF WOOD FIBER

- Limited erosion control effectiveness.
- Short-term use of 1 growing season.

HYDRAULIC MATRICES

- Avoid applying mulch 24 hours before an anticipated rainfall event, during a rainfall event, or immediately after a rainfall event.
- Hydromulch requires a drying time of 24 hours.
- To ensure complete coverage over roughen terrain, hydromulch may have to be applied from multiple angles and sides.

What to Inspect

- Is mulch applied to areas which will be regraded and/or revegetated?
- Is there uniform and complete coverage?
- Was the application rate sufficient for the disturbed area?
- Is there evidence of rill or gullies?

Maintenance

- Mulches applied to seeded areas may be disturbed due to wind or runoff. Recover exposed areas until permanent vegetation has been established.
- Replace ornamental and landscape mulches of bark or wood chips if soil is visible in more than 75% of the designated area.
- If erosion has occurred, additional mulch may be required.



Description

Application of soil binders to exposed soil to temporarily prevent water- and wind-induced erosion.

Applications

- Disturbed areas requiring short-term temporary protection.
- Good alternative to mulches in areas where grading activities will soon resume.
- Suitable for use on stockpiles.
- Applied in conjunction with mulching or seeding applications.

Installation and Implementation Requirements

- Soil types will dictate appropriate soil binders to be used.
- A soil binder must be environmentally benign (non-toxic to plant and animal life), easy to apply, easy to maintain, economical, and must not stain paved or painted surfaces. Soil binders must not pollute storm water. Prior to application, submit the manufacturer's material product data sheets to the Engineer for review and approval.
- Performance of soil binders depends on temperature, humidity, and traffic across treated areas.
- Avoid overspray onto roads, sidewalks, lined drainage channels (i.e., concrete swales and concrete culverts), existing vegetation, etc.

Installation and Implementation Requirements *(continued)*

SELECTING A SOIL BINDER

- Properties of common soil binders used for erosion control are provided in Table EC-16.3. Use the Table to select an appropriate soil binder.
- Consult with the Engineer if soil binders are an appropriate option for temporary stabilization.
- Factors to consider when selecting a soil binder include the following:
 - Suitability to situation
 - Consider where the soil binder will be applied, if it needs a high resistance to leaching or abrasion, and whether it needs to be compatible with any existing vegetation. Determine the length of time soil stabilization will be needed, and if the soil binder will be placed in an area where it will degrade rapidly. In general, slope steepness is not a discriminating factor for the listed soil binders.
 - Soil types and surface materials
 - Fines and moisture content are key properties of surface materials. Consider a soil binder's ability to penetrate, likelihood of leaching, and ability to form a surface crust on the surface materials.
 - Frequency of application
 - The frequency of application can be affected by subgrade conditions, surface type, climate, and maintenance schedule. Frequent applications could lead to high costs. Application frequency may be minimized if the soil binder has good penetration, low evaporation, and good longevity. Consider also that frequent application will require frequent equipment cleanup.

PLANT-MATERIAL BASED (SHORT-LIVED) BINDERS

- Guar: Guar is a non-toxic, biodegradable, natural galactomannan (or plant carbohydrates/sugars) based hydrocolloid treated with dispersant agents for easy field mixing. It must be mixed with water at the rate of 11 to 15 pounds per 1,000 gallons. Recommended minimum application rates are as provided in table EC-16.1.
- Psyllium: Psyllium is composed of the finely ground mucilloid coating of seeds (from Plantago plant) that is applied as a dry powder or in a wet slurry to the surface of the soil. It dries to form a firm but rewettable membrane that binds soil particles together but permits germination and growth of seed. Psyllium requires 12- to 18-hours drying time. Application rates must be 80 to 200 pounds/acre, with enough water in solution to allow for a uniform slurry flow.
- Starch: Starch is non-ionic, cold water soluble (pre-gelatinized) granular cornstarch. The material is mixed with water and applied at the rate of 150 pounds/acre. Approximate drying time is 9 to 12 hours.

Table EC-16.1 Application rates for Guar soil stabilization.

Slope Gradient (H:V)	Pounds/Acre
• Flat	• 40
• 4:1	• 45
• 3:1	• 50
• 2:1	• 60
• 1:1	• 70

Installation and Implementation Requirements *(continued)*

PLANT-MATERIAL BASED (LONG-LIVED) BINDERS

- Pitch and Rosin Emulsion: Generally, a non-ionic pitch and rosin emulsion has a minimum solids content of 48%. The rosin must be a minimum of 26% of the total solids content. The soil stabilizer must be non-corrosive, water dilutable emulsion that upon application cures to a water insoluble binding and cementing agent. For soil erosion control applications, the emulsion is diluted and must be applied as follows:
 - For clayey soil: 5-parts water to 1-part emulsion.
 - For sandy soil: 1-part water to 1-part emulsion.
- Application can be by water truck or hydraulic seeder with the emulsion and product mixture applied at the rate specified by the manufacturer.

POLYMERIC EMULSION BLEND BINDERS

- Acrylic Copolymers and Polymers: Polymeric soil stabilizers must consist of a liquid or solid polymer or copolymer with an acrylic base that contains a minimum of 55% solids. The polymeric compound must be handled and mixed in a manner that will not cause foaming or must contain an anti-foaming agent. The polymeric emulsion must not exceed its shelf life or expiration date; manufacturers should provide the expiration date. Polymeric soil stabilizer must be readily miscible in water, non-injurious to seed or animal life, non-flammable, must provide surface soil stabilization for various soil types without totally inhibiting water infiltration, and must not reemulsify when cured. The applied compound should air cure within a maximum of 36 to 48 hours. Liquid copolymer must be diluted at a rate of 10-parts water to 1-part polymer and the mixture applied to soil at a rate of 1,175 gallons/acre.

Installation and Implementation Requirements *(continued)*

- **Liquid Polymers of Methacrylates and Acrylates:** This material consists of a tackifier/sealer that is a liquid polymer of methacrylates and acrylates. It is an aqueous 100% acrylic emulsion blend of 40% solids by volume that is free from styrene, acetate, vinyl, ethoxylated surfactants, or silicates. For soil stabilization applications, it is diluted with water in accordance with manufacturer's recommendations and applied with a hydraulic seeder at the rate of 20 gallons/acre. Drying time is 12 to 18 hours after applications.
- **Copolymers of Sodium Acrylates and Acrylamides:** These materials are non-toxic, dry powders that are copolymers of sodium acrylate and acrylamide. They are mixed with water and applied to the soil surface for erosion control at rates that are determined by slope gradient, as described in Table EC-16.2.
- **Polyacrylamide and Copolymer of Acrylamide:** Linear copolymer polyacrylamide is packaged as a dry flowable solid. When used as a standalone stabilizer, it is diluted at a rate of 11 pounds/1,000 gallons of water and applied at the rate of 5 pounds/acre.
- **Hydro-Colloid Polymers:** Hydro-Colloid Polymers are various combinations of dry flowable polyacrylamides, copolymers and hydro-colloid polymers that are mixed with water and applied to the soil surface at rates of 55 to 60 pounds/acre. Drying time is 0 to 4 hours.

Table EC-16.2 Application rates for copolymers of sodium acrylates and acrylamides.

Slope Gradient (H:V)	Pounds/Acre
• Flat to 5:1	• 3 – 5
• 5:1 to 3:1	• 5 – 10
• 2:1 to 1:1	• 10 – 20

CEMENTITIOUS-BASED BINDERS

- **Gypsum:** This is a formulated gypsum-based product that readily mixes with water and mulch to form a thin protective crust on the soil surface. It is composed of high purity gypsum that is ground, calcined and processed into calcium sulfate hemihydrate with a minimum purity of 86%. It is mixed in a hydraulic seeder and applied at rates of 4,000 to 12,000 pounds/acre. Drying time is 4 to 8 hours.

Installation and Implementation Requirements *(continued)*

APPLYING SOIL BINDERS

- After selecting an appropriate soil binder, the untreated soil surface must be prepared before applying the soil binder. The untreated soil surface must contain sufficient moisture to assist the agent in achieving uniform distribution. The following steps shall be followed:
 - Follow manufacturer’s specifications for application rates, pre-wetting of application area, and cleaning of equipment after use.
 - Prior to application, roughen embankment and fill areas.
 - Consider the drying time for the selected soil binder and apply with sufficient time before anticipated rainfall. Soil binders shall not be applied during or immediately before rainfall.
 - Avoid overspray onto roads, sidewalks, drainage channels (i.e., concrete swales and concrete culverts), sound walls, existing vegetation, etc. Soil binders shall not be applied to areas with standing water, under rainy conditions, or when the temperature is below 40° Fahrenheit during the curing period.
 - More than 1 treatment is often necessary, although the second treatment may be diluted or have a lower application rate.
 - Generally, soil binders require a minimum curing time of 24 hours before they are fully effective. Refer to manufacturer’s instructions for specific cure time.
 - For liquid agents:
 - Crown or slope ground to avoid ponding.
 - Uniformly pre-wet ground at 0.03 to 0.3 gallons/yard² or according to manufacturer’s recommendations.
 - Apply solution under pressure. Overlap solution 6 to 12 inches.
 - All treated area to cure for the time recommended by the manufacturer; typically, at least 24 hours.
 - Apply second treatment before first treatment becomes ineffective, using 50% application rate.
 - In low humidity, reactivate chemicals by rewetting with water at 0.1 to 0.2 gallons/yard².



Soil binders can be used on large stockpiles to prevent erosion from wind and rain.

Considerations

- Soil binders are temporary in nature and may need reapplication.
- Some soil binders may not be compatible with existing vegetation.
- Soil binders require a minimum curing time until fully effective, as prescribed by the manufacturer.
- Soil binders may need reapplication after a rain event.
- Soil binders will generally experience spot failures during heavy rainfall events. If runoff penetrates the soil at the top of a slope treated with a soil binder, it is likely that the runoff will undercut the stabilized soil layer and discharge at a point further down slope.
- Soil binders do not hold up to pedestrian or vehicular traffic across treated areas.
- Soil binders may not penetrate soil surfaces made up primarily of silt and clay, particularly when compacted.
- Some soil binders may not perform well with low relative humidity. Under rainy conditions, some agents may become slippery or leach out of the soil.
- Soil binders may not cure if low temperatures occur within 24 hours of application.
- A sampling and analysis plan should be incorporated into the *Storm Water Pollution Prevention Plan (SWPPP)*, as soil binders could be a source of non-visible pollutants.

What to Inspect

- Has soil binder broken down due to natural elements?
- Is there evidence of erosion?
- Does the soil binder need to be reapplied?
- Are the soil binders an effective BMP for the area?

Maintenance

- Repair areas where erosion is evident and reapply BMPs as soon as possible. Care must be exercised to minimize the damage to protected areas while making repairs, as any area damaged will require reapplication of BMPs.
- Reapply the selected soil binder as needed to maintain effectiveness.

Soil Binders

Table EC-16.3 Properties of soil binders used for erosion control.

Evaluation Criteria	Binder Type			
	Plant Material Based (Short-lived)	Plant Material Based (Long-lived)	Polymeric Emulsion Blends	Cementitious-Based Binders
Relative Cost	Low	Low	Low	Low
Resistance to Leaching	High	High	Low to Moderate	Moderate
Resistance to Abrasion	Moderate	Low	Moderate to High	Moderate to High
Longevity	Short to Medium	Medium	Medium to Long	Medium
Minimum Curing Time Before Rain	9 to 18 hours	19 to 24 hours	0 to 24 hours	4 to 8 hours
Compatibility with Existing Vegetation	Good	Poor	Poor	Poor
Mode of Degradation	Biodegradable	Biodegradable	Photodegradable/ Chemically Degradable	Photodegradable/ Chemically Degradable
Labor Intensive	No	No	No	No
Specialized Application Equipment	Water Truck or Hydraulic Mulcher	Water Truck or Hydraulic Mulcher	Water Truck or Hydraulic Mulcher	Water Truck or Hydraulic Mulcher
Liquid/Powder	Powder	Liquid	Liquid/powder	Powder
Surface Crusting	Yes, but dissolves on rewetting	Yes	Yes, but dissolves on rewetting	Yes
Clean Up	Water	Water	Water	Water
Erosion Control Application Rate	Varies	Varies	Varies	4,000 to 12,000 pounds/acre



This page intentionally left blank.



CHAPTER 3. SEDIMENT CONTROL

Sediment Control (SC) BMPs are controls implemented on a construction site that limit the amount of sediment transported and deposited off-site. SC BMPs serve as treatment measures by providing a second line of defense. SC BMPs are used to detain sediment-laden storm water runoff and promote infiltration and/or sedimentation.

In this chapter:

- General Practices
- Sediment Containment Systems
- Sheet Flow BMPs
- Tracking BMPs



Description

Devices installed at storm drain inlets that detain large objects and sediment-laden runoff prior to entering the storm drain system. These devices are often the last treatment measure, so a layered BMP approach is crucial to mitigating sediment-laden runoff from entering the State of Hawaii Department of Transportation (HDOT) Highways MS4 or storm drainage system, including surface waters.

Applications

- All storm drain inlets, both within the project limits and beyond the project limits, that may intercept sediment-laden runoff from the construction site shall be protected prior to commencing land-disturbing activity.
- Where disturbed areas have not been stabilized.

Installation and Implementation Requirements

- Install inlet protection devices prior to upgradient land-disturbing activity.
- Inlet protection causes ponding, which is necessary to allow the sediment to settle. The storm drain inlet must not be completely blocked when public safety is of concern.
- The contractor shall monitor the weather for rainfall events and coordinate with the Engineer to adjust inlet protection to prevent hazardous conditions and flooding.
- For maximum effectiveness, minimize the demand on inlet protection devices by installing and maintaining erosion and sediment control devices upslope of the inlet.

Installation and Implementation Requirements *(continued)*

- Immediately stabilize slopes and disturbed areas that are no longer active to reduce potential runoff. Inlet protection shall only be removed once disturbed areas upgradient of the catch basin has been stabilized.
- Grated drop inlets and curb inlets/catch basins are the 2 types of inlets most present on construction sites. There are various types of BMP devices that are applicable in protecting these inlets from accepting sediment-laden runoff.



Properly installed geotextile filter fabric is placed underneath the grate and extends 6 inches past the grate on all sides.

GRATED DROP INLET (GDI)

- Installing a geotextile filter fabric under the grate to cover the insert is a common inexpensive practice to prevent sediment from entering the GDI. The fabric should be placed fully under the grate to completely shield the inlet. Allow 6 inches, minimum, of excess fabric to extend past the grate on all sides. The fabric is easily clogged by sediment. Other methods are preferred such as a witch's hat, which will facilitate drainage while filtering sediment.
- Compost filter socks or sand bags can be placed around the perimeter of the GDI, to divert and/or detain storm water before it enters the inlet. *See* section SC-6 Compost Filter Berm/Sock and section SC-8 Sandbag Barrier for more information.
- The following list below are applicable devices for GDI's:
 - Geotextile filter fabric fence.
 - Geotextile filter fabric under grate.
 - Witch's hat
 - Inbox protection.
 - Fiber roll with additional in box protection.
 - Sand bag, rock bag, or snake bag.

CURB INLET/CATCH BASIN

- Devices installed at curb inlets are in place to prevent sediment-laden runoff from entering the storm drain. An ample amount of space must be provided to allow water to pond around the inlet. This allows the sediment to settle, as the storm water slowly enters the MS4.



Properly installed curb inlet guards are placed tight to the drain opening and anchored per manufacturer's specifications.

Installation and Implementation Requirements *(continued)*

- Devices must extend at least 1 foot past the inlet insert on both sides, unless manufacturer's specifications differ.
- Non-destructive supporting brackets may be used to prevent inlet protection devices from falling into the curb inlet/catch basin.
- Ensure flooding of nearby properties or impeding traffic is avoided.
- Use check dams to reduce the demand of sediment-laden runoff flowing towards a curb inlet. *See* section SC-3 Check Dams for more information.
- In addition to the methods of inlet protection described above, there are other effective methods and proprietary devices, which may also be used. These are limited to drainage areas that are less than 1 acre, unless a sediment trap intercepts the runoff prior to reaching the inlet protection device.
- Other proprietary devices may be used and shall be installed per manufacturer's recommendations.

Considerations

- Short-term flooding at a protected inlet will occur but must not become a traffic or pedestrian hazard.
- Drainage area is limited to 1 acre or less.
- Straw bales shall not be used for inlet protection.
- Runoff on slopes may bypass protected inlets.
- In the event of a severe storm event where flooding conditions will likely be an issue; the contractor may be directed by the Engineer to remove inlet protection. The inlet protection must be reinstalled immediately following the event.
- Geotextile filter fabric used to protect GDI inserts must be cleaned or replaced often due to the limited capacity of sediment the device can hold.
- Inlet protection devices can be tedious to maintain and become ineffective when sediment accumulates. Regular maintenance is required.
- Inlet protection is the last line of defense, which requires proper erosion and sediment controls in place upgradient.
- Inlet protection BMPs that completely block the insert will cause ponding that could create a traffic and pedestrian hazard or cause damage to nearby properties.
- Some GDI grates require heavy machinery to remove the grate to install geotextile filter fabric.

What to Inspect

- Is proper contact made against curb and gutter to prevent water from undercutting or bypassing inlet protection?
- Can sediment enter catch basin from the top or backside of the structure?
- Is sediment accumulated in front or inside of the inlet protection?
- Is the catch basin insert installed properly and being maintained per manufacturers guidelines?
- Is BMP falling into the inlet?
- Does sediment need to be removed?
- Are there rips/tears in BMP that will allow sediment to bypass it?
- Are compost filter socks damaged with rips/tears that expose the compost media?
- Is there evidence of sediment settling in front of the storm drain following a rain event?

Maintenance

- Routine maintenance should be initiated the same day the deficiency is identified and completed by the end of the same business day.
- Installation of a new erosion or sediment control device or a significant repair to a device shall be completed within 7 calendar days.
- Immediately replace clogged geotextile filter fabric or stone filters.
- Devices must be inspected, and all accumulated sediment removed before and after each rainfall event.
- During prolonged rainfall events, remove accumulated sediment when depth reaches one-half of the filter height or one-half of the sediment trap depth.
- Remove inlet protection only after stabilization of upstream soils and sweeping of streets is completed. Properly dispose of trapped sediment.
- Clean, remove, or replace protection measures as sediment accumulates, filter becomes clogged, and/or performance is compromised.
- When there is evidence of sediment accumulation adjacent to the inlet protection measures, remove deposited sediment by the end of the same day in which it is found or by the end of the following work day if removal by the same day is not possible.



If inlet protection BMPs are falling into the inlet, they must be pulled out and repositioned, per manufacturer's specifications.



Storm Drain Inlet Protection

Maintenance *(continued)*

- Devices that fall into inlets must be pulled out and repositioned. Devices must be installed per the manufacturer's specifications and procedures for proper effectiveness.
- Address devices experiencing flow bypasses over, underneath, or around the sides of the BMP.
- Regularly maintain inlet protection devices to abide by manufacturer's specifications.

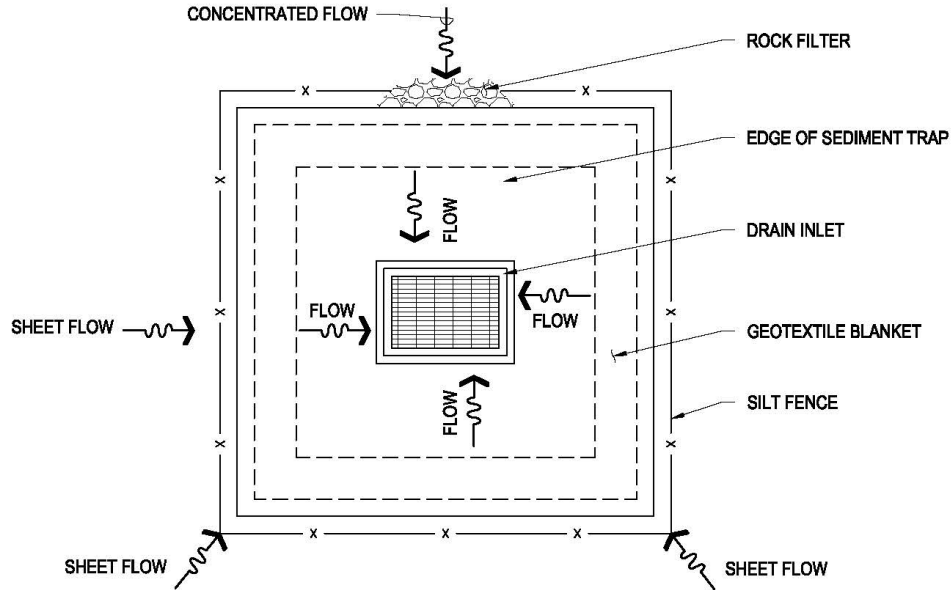

PLAN
NOT TO SCALE

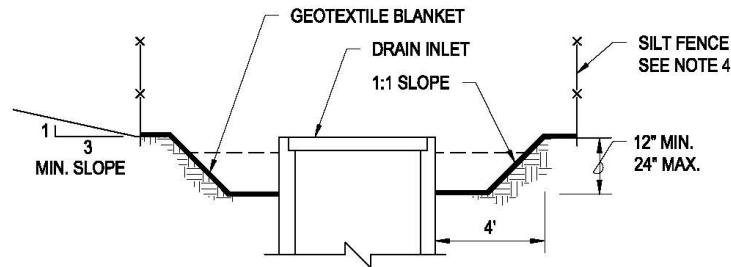

SECTION
NOT TO SCALE

NOTE:

1. FOR USE IN CLEARED AND GRUBBED AND IN GRADED AREAS.
2. FOR CONCENTRATED FLOWS, SHAPE BASIN IN 2:1 (L:W) RATIO WITH LENGTH ORIENTED TOWARDS DIRECTION OF FLOW.
3. SIZE EXCAVATED TRAP TO PROVIDE A MINIMUM STORAGE CAPACITY CALCULATED AT THE RATE 67 YD³/ACRE OF DRAINAGE AREA.
4. REFER TO BMP SC-7, SILT FENCE OR FILTER FABRIC FENCE.

EXCAVATED DROP INLET SEDIMENT TRAP

Storm Drain Inlet Protection

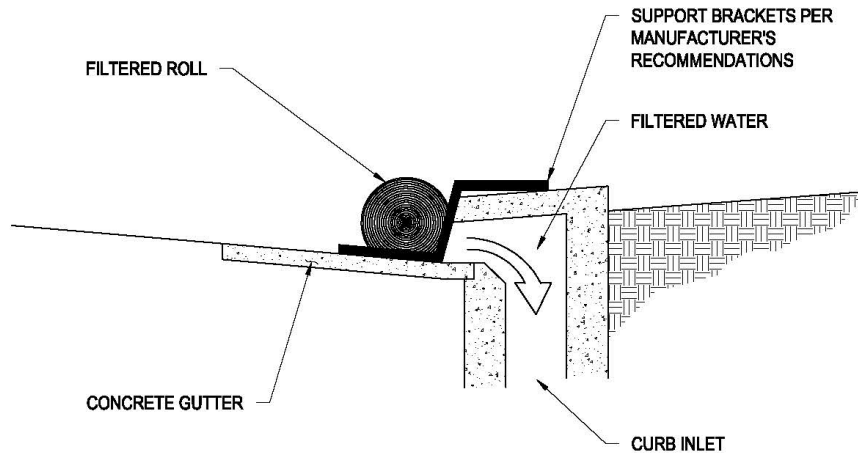

FILTER ROLL WITH SUPPORTS FOR CURB INLET
NOT TO SCALE

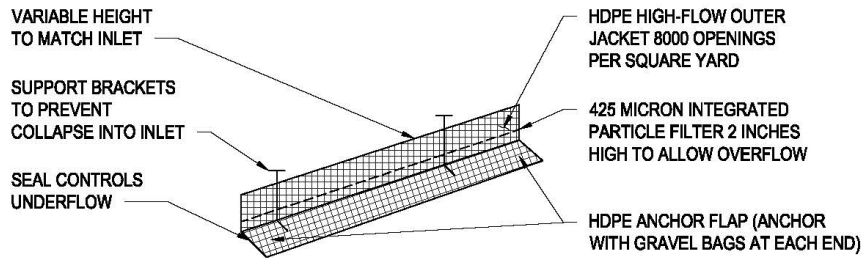

NOTES:

1. ADD GRAVEL BAGS AT ENDS AND EACH OVERLAP.

GEOTEXTILE INSERT WITH SUPPORTS FOR CURB INLET
NOT TO SCALE



Description

Vegetative buffer strips and channels help to protect ditches and banks from erosion, increase infiltration, and remove pollutants from surface runoff providing protection to downstream receiving inlets and waterbodies.

Applications

- Any site suitable for establishment of vegetation.
- Vegetated buffer strips are appropriate for uncurbed, paved areas; steep slopes; potentially unstable slopes; and areas adjacent to sensitive waterbodies and state waters.
- Vegetated channels are appropriate for surface runoff conveyed by channels to downstream inlets or receiving waters.

Installation and Implementation Requirements

- Minimize the disturbance to existing vegetation at the site when installing a filter strip. Proper care of existing vegetation before and after construction is required. *See* section SM-17 Preservation of Existing Vegetation for more information.
- If a boundary of the disturbed area is within 50 feet of state waters, comply with 1 of the following:
 - Provide and maintain a 50-foot undisturbed natural buffer and sediment control .

Installation and Implementation Requirements *(continued)*

- Provide and maintain an undisturbed natural buffer that is less than 50 feet and double sediment control (e.g., double perimeter control) spaced a minimum of 5 feet apart.
- If it is infeasible to provide and maintain an undisturbed natural buffer of any size, provide and maintain double sediment control (e.g., perimeter control) spaced a minimum of 5 feet apart and complete stabilization within 7 calendar days of the temporary or permanent cessation of earth-disturbing activities.
- Hawaii Revised Statutes Title 13. Planning and Economic Development 205A. Coastal Zone Management defines "shoreline" as "the upper reaches of the wash of the waves at high tide during the season of the year in which the highest wash of the waves occurs, excluding storm surge or seismic action". The shoreline is considered the starting point for any buffer/filter strips employed during construction. Perimeter control BMPs must be placed according to where the shoreline has been defined.
- Vegetation must be fully established before storm water flows through the buffer. Vegetation used should be competitive with common weed species in area.
- Installation of a buffer strip with new vegetation shall comply with the following:
 - Prior to cultivation of the designated buffer strip area, remove and dispose of all weeds and debris in accordance with the following:
 - During construction, strip and stockpile good topsoil for surface preparation purposes prior to planting activities.
 - Plant the area upon completion of grading in the area.
 - Do not remove trees to create an area for vegetated filter strips.
 - Vegetated filter strips shall be sloped 5% or less. This allows the storm water to be pulled down the slope by gravity, while moving slow enough to allow sediment and pollution removal.
 - Fine grade and roll areas to be planted after cultivating soil and, if applicable, installing the irrigation system.
 - Provide additional watering or irrigation of vegetation to supplement rainfall until vegetation has been established.
 - Fertilize vegetation in accordance with manufacturer's instructions and grass/soil requirements determined by testing of the soil.



If state waters are located within 50 feet of disturbed area and an undisturbed natural buffer less than 50 feet is used, install double sediment control spaced a minimum of 5 feet apart.

Installation and Implementation Requirements *(continued)*

- Soil should not be compacted. Loosen soil and add top soil as needed before seeding.
 - Vehicular traffic passing through vegetated buffer strips or channels shall be avoided to protect vegetation from damage and maximize its effectiveness.
 - Comply with applicable regulations and manufacturer’s instructions when applying fertilizers, pesticides, soil amendments, or chemicals.
 - Wider filter strips will be more effective and remove finer sediments.
 - Vegetated filter strips should be a minimum width of 5 feet.
 - Buffer strip edges should have dense growth to breakup concentrated flow.
- Seeding activities shall comply with the following:
- Add soil amendments such as fertilizer when preparing seedbed. Apply mulch after seeding to protect vegetation during establishment. Select an appropriate seed mixture based on site conditions.
 - Seed mixture should receive HDOT approval in writing prior to installation.
 - Native plants are required, but non-native plants can be used if accepted by the Engineer.
 - Dense grasses are more effective in reducing flow velocities and removing sediment. Thick root structures are necessary for erosion control.
 - Use proper equipment and methods to ensure uniform distribution and appropriate seed placement.
 - Overseed, repair bare spots, and apply additional mulch as necessary.
- Sodding activities shall comply with the following:
- Protect sod with tarps or other types of protective covering during delivery and do not allow sod to dry between harvesting and placement.
 - Restore any irregular or uneven areas observed prior to or during the plant establishment period to a smooth and even appearance.
 - Ensure ground surface is smooth and uniform prior to placing sod.
 - Areas which will be planted with sod and are adjacent to paved surfaces such as sidewalks and concrete headers, shall be 1.5 ± 0.25 inches below the top grade of the paved surface after fine grading, rolling, and settlement of the soil.
 - Stagger the ends of adjacent strips of sod a minimum of 24 inches apart.
 - Place edges and ends of sod firmly against paved borders.



Additional watering or irrigation to supplement rainfall may be needed until vegetation has been established.

Installation and Implementation Requirements *(continued)*

- Lightly roll sodded area to eliminate air pockets and ensure close contact with the soil after placement of the sod.
- Water the sodded area to moisten the soil to a depth of 4 inches after rolling.
- Do not allow sod to dry.
- Avoid planting sod during extremely hot or wet weather.
- Sod shall not be placed on slopes steeper than 3:1 (H:V) if the area will be mowed.

Considerations

- Site conditions such as availability of land.
- Flow depth and vegetative condition determine BMP effectiveness.
- May require irrigation to maintain vegetation.
- High maintenance requirements may exist depending on the design condition of the vegetation.
- Unless existing vegetation is used as a buffer strip, an area will need to be provided specifically for a buffer strip and vegetation will need to be established.
- Maintaining sheet flow in buffer strips may be difficult.
- Vegetated channels require a larger area than lined channels.
- Vegetated channels require gradual slopes since runoff with high flow velocity may flow over grass rather than through it. Buffer zones do not replace the requirement for site sediment control.
- BMP performance depends on topography and climate conditions for the specific site.

What to Inspect

- Is there an excess amount of sediment buildup in buffer strips?
- Are buffer strips wide enough to be effective?
- Are rills and gullies formed from runoff?
- Is unwanted vegetation growth observed?
- Are vegetated filter strips fully established prior to receiving flow?
- Have native grasses/plants been planted?

Maintenance

- Maintenance activities include mowing, weeding, and verification of properly operating irrigation system, if applicable.
- Properly remove and dispose of clippings from mowing and trimming.
- When installed correctly, filter strips require minimal maintenance.
- Unwanted growth should be removed without disrupting existing vegetation.
- Maintain vegetated filter strips so it remains dense and healthy.
- If check dams are installed, repair/replace as necessary.



If check dams are installed in a vegetated buffer strip, they must be repaired/replaced as necessary.

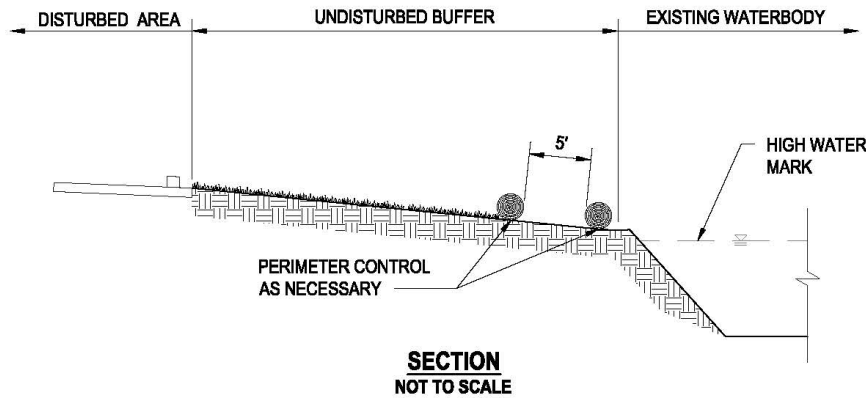
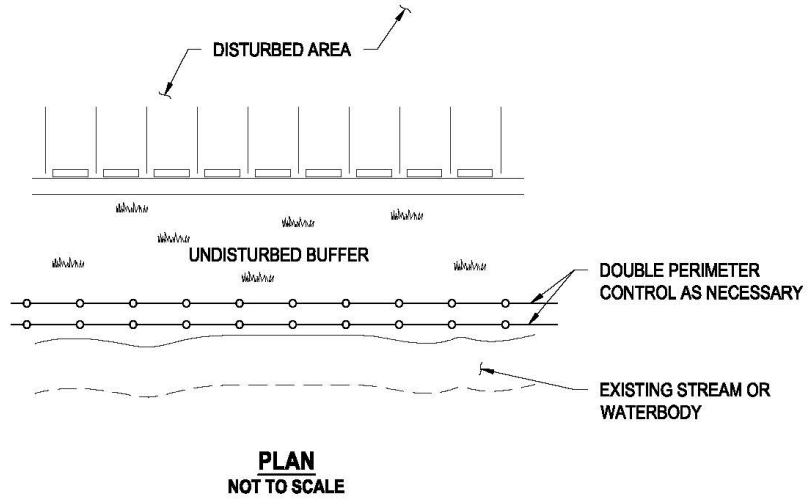

TYPICAL VEGETATED BUFFER STRIP

NOTES:

1. PROVIDE AND MAINTAIN A 50-FOOT UNDISTURBED BUFFER AND SEDIMENT CONTROL FROM STATE WATERS.
2. IF THE EARTH DISTURBANCES ARE LOCATED LESS THAN 50 FEET FROM STATE WATERS, MAINTAIN AN UNDISTURBED NATURAL BUFFER AND INSTALL DOUBLE SEDIMENT CONTROL (E.G. DOUBLE PERIMETER CONTROL) SPACED A MINIMUM OF 5 FEET APART.
3. THE DEPARTMENT DOES NOT CONSIDER ALL STORM WATER CONTROL FEATURES (E.G. STORM WATER CONVEYANCE CHANNELS, STORM DRAIN INLETS, SEDIMENT BASINS) TO BE STATE WATERS.



Description

Temporary devices placed across channels, ditches or swales to reduce scour and erosion by reducing flow velocity and promoting sedimentation.

Applications

- Appropriate for small open channels conveying runoff from 10 acres or less.
- Steep channels with runoff velocities exceeding 2 feet/second.
- Temporary ditches which do not require installation of erosion-resistant linings due to expected short-term use.
- May be used in a curb and gutter scenario.

APPLICABLE CHECK DAM DEVICES

- Rocks
- Sandbags/gravel bags wrapped in geotextile
- Logs
- Snake bags
- Compost filter berms/socks

Installation and Implementation Requirements

- Distance between check dams and height of each device shall promote the formation of small pools between adjacent devices.
- Backwater from the downstream check dam shall reach the toe of the upstream check dam.
- Major flows shall flow over the check dam without increasing upstream flooding or damaging the check dam.
- Remove check dams and accumulated sediment upon establishment of vegetative lining.
- Stone check dams shall consist of stones ranging from approximately 8 to 12 inches in size.
 - Stones shall be placed by hand or by other mechanical means, not dumped.
 - Stone material shall completely span the channel or ditch to prevent washout of the check dam.
 - Geotextile should be installed under stone check dams. Check dams should be 6 inches lower in the center than at the ends to allow flow over the center.
- Log check dams shall consist of logs ranging from 4 to 6 inches in diameter. Logs shall be embedded a minimum of 18 inches into the soil.
- Remove check dams upon establishment of grass used for stabilization of the ditch or channel, unless the slope of the swale exceeds 4%.



The bottom of the upstream check dam should be at the same elevation as the top of the downstream check dam to promote the formation of small pools between check dams.

Considerations

- Drainage area discharging to open channels shall not exceed 10 acres.
- Not applicable to live streams and rivers.
- Not applicable to channels with established grass linings unless erosion is expected since check dam installation may damage existing vegetation.
- High velocity flows may require extensive maintenance.
- Subsequent storms or removal of the check dam may resuspend trapped sediment.

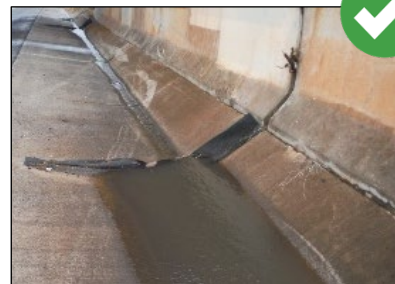

The center of the check dam must be lower than the ends to prevent water from running around the ends and causing additional erosion.

What to Inspect

- Is height of check dam effective?
- Is there evidence of sediment bypassing the check dam?
- Does the rock check dam have dislodged stones?
- Are check dams adequately spaced to slow the velocity of flow?
- Is there traces of undercutting?
- Has accumulated sediment reached one-half the height of the check dam?
- Are check dams the required diameter?
- Are check dams properly oriented?

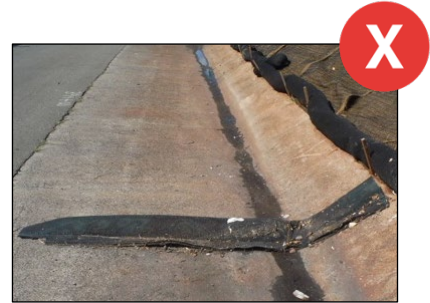

Check dams that get flattened must be repaired/replaced.

Maintenance

- Remove accumulated sediment when depth reaches one-half the sump depth.
- Replace/repair damaged gravel bags or sandbags.
- Replace dislodged stones from rock check dams to sustain initial design.
- Reposition and clean compost filter sock check dams that get pushed out of position by a heavy flow.

Check Dams

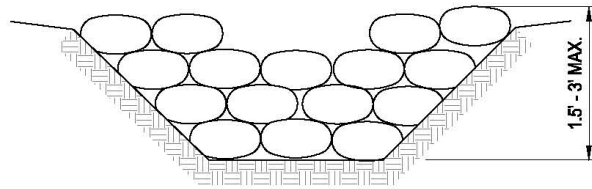

GRAVEL BAG CHECK DAM ELEVATION
NOT TO SCALE

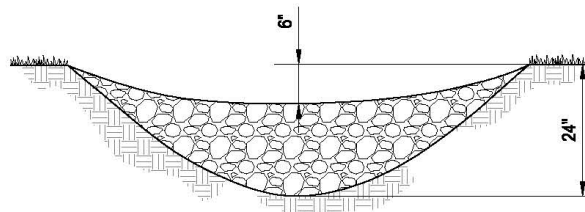

STONE CHECK DAM ELEVATION
NOT TO SCALE

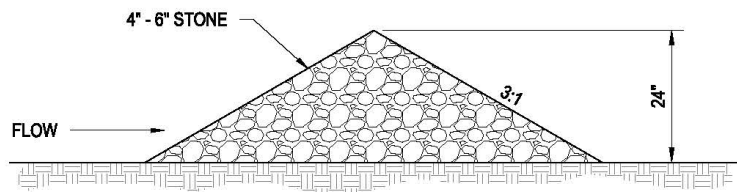

STONE CHECK DAM SECTION
NOT TO SCALE

Check Dams

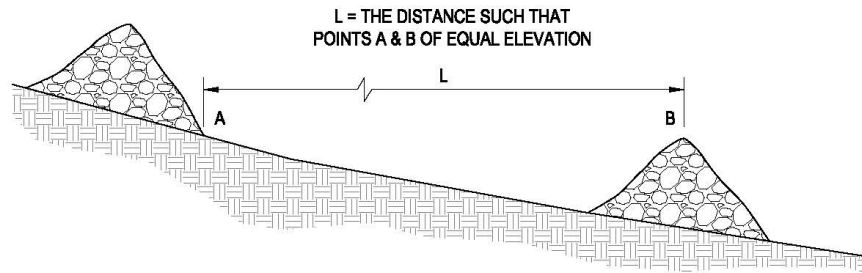

SPACING BETWEEN CHECK DAMS
NOT TO SCALE



Description

A temporary runoff containment area to promote sedimentation prior to discharge of the runoff through a stabilized spillway.

Applications

- Drainage areas less than 5 acres.
- Areas along the perimeter of the site where sediment-laden runoff is discharged off-site.
- Areas requiring additional sediment containment measures such as bodies of water or discharge points to a drainage system.
- On-site discharge points to a stabilized or natural area or waterway.

Installation and Implementation Requirements

- Construct sediment trap prior to engaging in clearing, grubbing, or grading activities.
- Location shall be based on the following:
 - Area where a low embankment may be constructed across a swale.
 - Area where failure of sediment trap will not cause property damage or loss of life.
 - Area where maintenance crew may easily access sediment trap.

Installation and Implementation Requirements *(continued)*

- Sediment trap size shall be based on the following:
 - Minimum trap settling volume of 133 cubic yards per acre.
 - Minimum trap sediment storage volume of 33 cubic yards per acre.
 - Trap width shall be less than one-half of the trap length.
 - Flood volume.
 - Construct sediment trap by excavating ground or constructing an earthen embankment to create a containment area.
- Area under embankment shall be cleared, grubbed, and stripped of vegetation and root mat.
- Fill material for embankment shall be free of roots, woody vegetation, oversized stones, rocks, organic material, or other objectionable material. Compact embankment by traversing with construction equipment.
- Stabilize trap outlet with stone or vegetation.
- Install fencing to prevent unauthorized entry and for safety purposes.
- All pipe joints shall be watertight when a riser is used.
- The top two-thirds of the riser shall be perforated with holes 1 to 4 inches in diameter. The holes shall be vertically spaced at 8-inch intervals and horizontally spaced at 10- to 12-inch intervals.
- Outlet crest elevation of an earth or stone outlet shall be a minimum of 1 foot below the top of the embankment.
- If the sediment trap is to remain in place for 14 calendar days or more, the embankments, berms, and other areas of exposed soil must be temporarily stabilized.



Construct sediment trap prior to engaging in clearing, grubbing, or grading activities.

Considerations

- Applies to maximum drainage area of 5 acres. Drainage areas exceeding 5 acres shall implement Sediment Basins. *See* section SC-5 Sediment Basin for more information.
- Only removes large and medium size particles.
- Requires protective fencing.
- Do not install in live streams.
- Availability of right-of-way may limit size of sediment trap.



Sediment Trap

What to Inspect

- Are spillways or outlets obstructed or damaged?
- Is there evidence of erosion at the outlets?
- Are the areas stabilized around outlets?
- Is fencing damaged?

Maintenance

- Remove obstruction and repair damage as necessary.
- Remove sediment which has accumulated to within 1 foot of the maximum storage elevation.
- Properly dispose of sediment and debris removed from sediment trap.

Sediment Trap

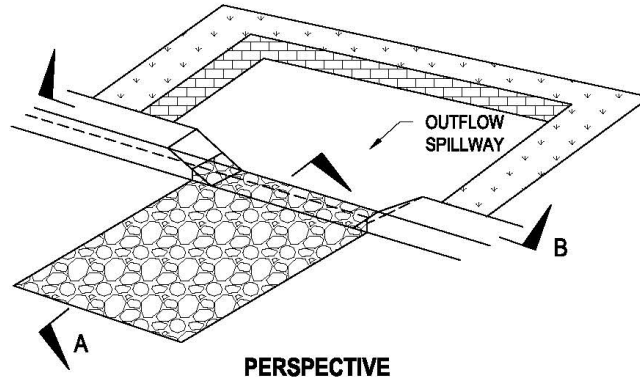

PERSPECTIVE
NOT TO SCALE

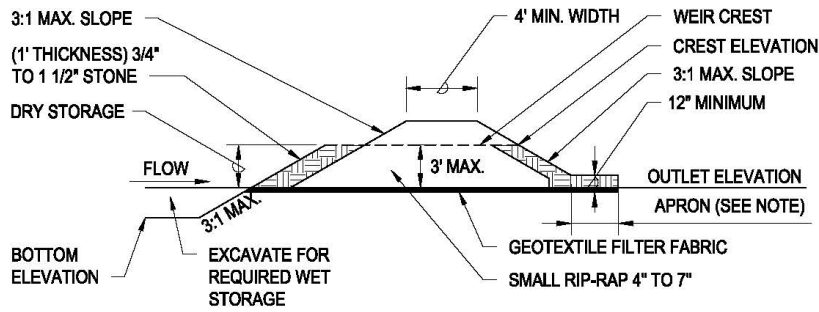

NOTE:

MAXIMUM DRAINAGE AREA = 5 ACRES

SECTION A
NOT TO SCALE

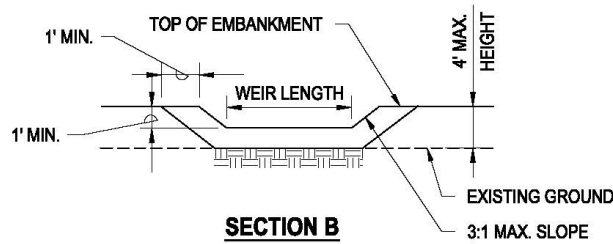

SECTION B
NOT TO SCALE

STONE OUTLET SEDIMENT TRAP

Sediment Trap

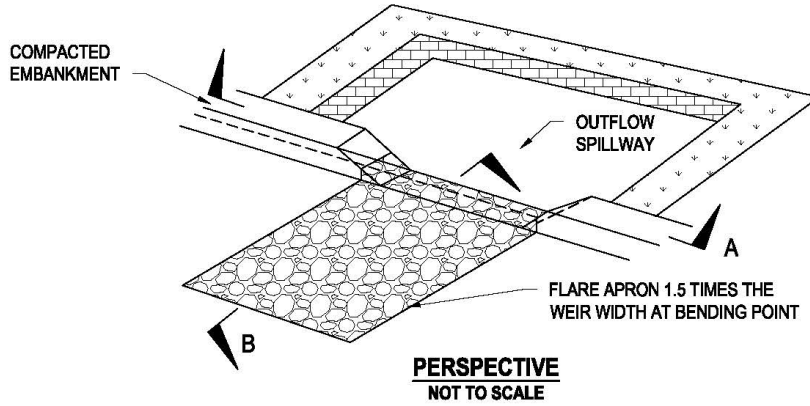

LEGEND:

a = MINIMUM DEPTH OF CHANNEL
b = BOTTOM WIDTH OF WEIR

TOP OF COMPACTED EMBANKMENT MINIMUM 1' ABOVE TOP OF STONE LINING. MAXIMUM 4' ABOVE EXISTING GROUND

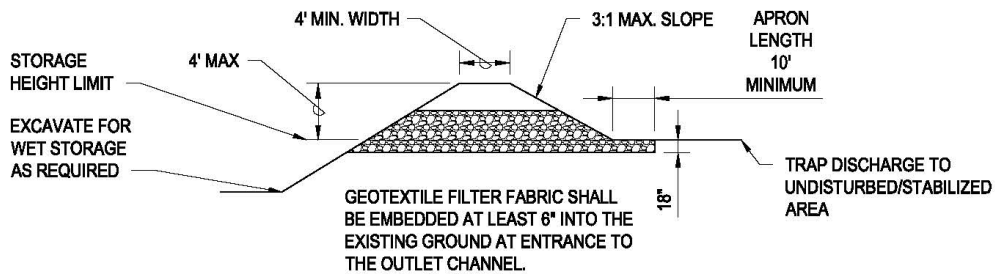
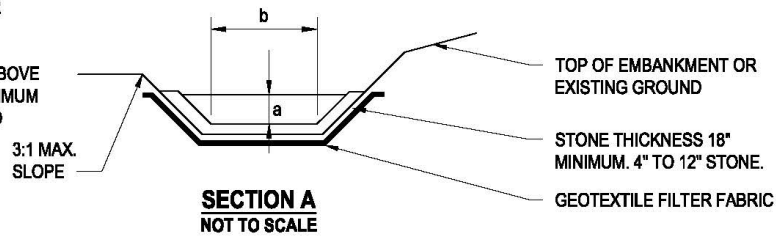

RIP-RAP SEDIMENT TRAP



Description

Temporary basin that intercepts sediment-laden runoff and allows sediment to settle prior to discharge of runoff from the site.

Applications

- Drainage areas larger than 5 acres.
- Areas where sediment-laden runoff is discharged to the drainage system or watercourses.

Installation and Implementation Requirements

- Construct sediment basins prior to clearing, grubbing, or grading activities.
- Location shall be based on the following:
 - Area where terrain forms a natural basin.
 - Area which minimizes construction interference.
 - Area where maximum benefit may be achieved from the existing terrain to minimize excavation or construction effort to install sediment basin.
 - Area where failure of sediment basin will not cause property damage or loss of life.



Sediment basins must be located in an area where failure of sediment basin will not cause property damage or loss of life.

Installation and Implementation Requirements *(continued)*

- Area where maintenance crew may easily access sediment basin.
- Area where permanent detention basin will be constructed.
- Sediment basin shall be designed to allow 70% to 80% of the sediment to settle during a 24- to 40-hour detention time.
- The sediment basin is divided into 2 zones:
 - Sediment storage zone with a minimum of 1 foot in depth.
 - Settling zone with a minimum of 2 feet in depth.
- Sediment basin design shall be based on the following requirements:
 - Settling zone volume shall be determined by the following equation:

$$V = 1.2(SD)Q/V_{SED}$$
 Where:
 V = Settling zone volume.
 SD = Settling depth, which shall be a minimum of 2 feet and greater than the average distance from inlet to outlet of the basin divided by 200.
 V_{SED} = Settling velocity of the design soil particle (medium silt). The settling velocity of a medium silt soil particle is 0.00096 feet per second.
 $Q = CIA$
 Where:
 Q = Discharge rate measured in cubic feet per second.
 C = Runoff coefficient.
 I = Precipitation intensity for the 10-year, 1-hour rain event.
 A = Area draining into the sediment basin in acres.
 - Basin geometry for the sediment storage zone shall be determined by a minimum depth of 1 foot and 3:1 (H:V) or flatter side slopes extending from the bottom of the basin. Basin bottom shall be level.
 - Provide an emergency spillway with the top of the riser pipe 1 foot below the crest elevation.
 - Sediment basin length to settling depth ratio (L/SD) shall not exceed 200.
 - Sediment basin length to width ratio shall not be less than 6:1 or baffles shall be installed.
- Install and securely anchor anti-seep collar on the outlet pipe/riser.



Inlets, outlets, and slopes of sediment basins must be stabilized with rock or vegetation to minimize erosion.

Installation and Implementation Requirements *(continued)*

- Construct sediment basin by excavating ground or constructing an embankment of compacted soil. Embankments should be stabilized.
- Sediment basin may have more than 1 inflow point.
- Stabilize inlet, outlet, and slopes of basin with rock or vegetation.
- Install fencing to prevent unauthorized entry and for safety purposes.
- Refer to the *Storm Water Permanent Best Management Practices Manual* for more information.

Considerations

- Limited design life of 12 to 18 months.
- Sediment basin removes medium size particles.
- Additional BMPs such as seeding, mulching, and diversion dikes may be used to reduce the amount of sediment intercepted by the basin.
- Requires protective fencing.
- Inappropriate for installation in live streams.
- Availability of right-of-way may limit size of sediment basin.
- Large basins may be subject to state and local requirements for dam safety.

What to Inspect

- Is there evidence of obstructions or damage to inlets and outlets?
- Is there erosion around outlets?
- Is fencing damaged?

Maintenance

- Remove obstructions from inlets and outlets and repair damage as necessary.
- Stabilize outlets and repair fencing as necessary.
- Remove sediment when the sediment storage volume is one-half full.
- Properly dispose of sediment and debris removed from sediment basin.

Sediment Basin

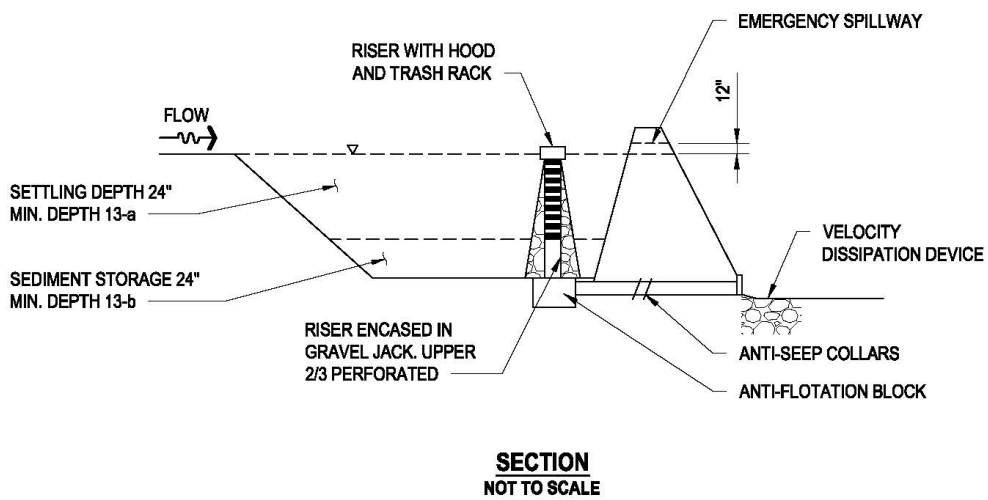
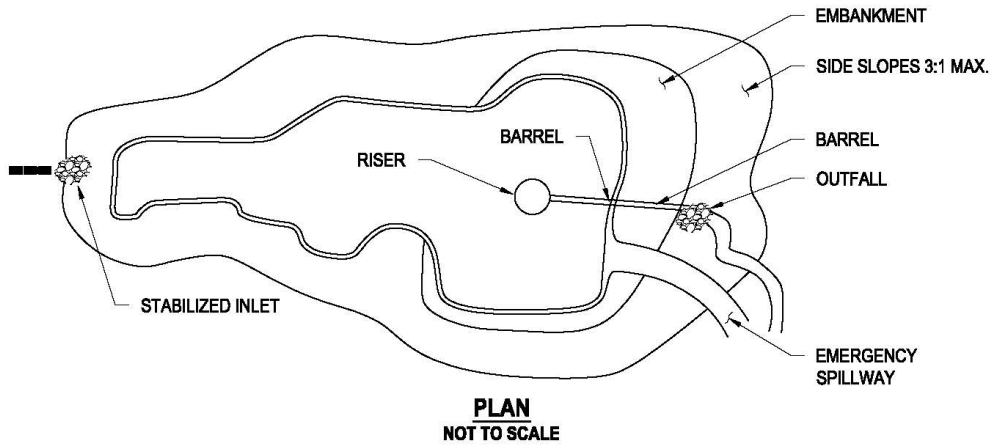

SEDIMENT BASIN



Description

Berms consisting of compost material placed perpendicular to runoff to reduce flow velocity and retain sediment and other pollutants. A fiber roll may consist of straw, flax, mulch, or other similar materials bound into a tight tubular roll.

Applications

- Along the site perimeter.
- Along the slope face and toe of slope (*See* section EC-5 Earth Dikes, Swales, and Ditches).
- Check dam in small drainage ditches (*See* section SC-3 Check Dams).
- Inlet protection for storm drains (*See* section SC-1 Storm Drain Inlet Protection).
- Surrounding base of temporary stockpiles (*See* section SM-3 Stockpile Management).
- Appropriate for small drainage areas and low surface velocity flows (less than 1 cubic feet per second (cfs)).
- Vegetative filtering system.
- Applied as a comprehensive system to storm water management.
- Used as perimeter control for disturbed/bare areas.

Installation and Implementation Requirements

- Usually located at the base of slopes, however, additional berms may be used for velocity dissipation devices mid-slope to increase erosion protection. *See* section EC-9 Slope Interceptor or Diversion Ditches/Berms for more information.
- Compost quality shall comply with all local, state, and federal requirements. Installation of a compost filter sock, which consists of a mesh tube filled with composted material, as a type of compost filter berm shall comply with the following:
 - Assemble by tying a knot at the end of the mesh sock, filling the sock with compost, and knotting the other end of the sock. A pneumatic blower may be used to fill the sock with compost.
 - Socks shall be 8 inches in diameter, minimum.
 - If more than 1 compost filter sock is placed in a row, the compost filter socks must be overlapped, not abutted. The overlap shall be 6 inches, minimum (or in accordance with the manufacturer’s recommendations), and shall be horizontal, side-by-side. The overlap shall not be vertical, top-to-bottom.
 - Compost filter socks used on concrete or other hard surfaces that make staking non-applicable should be weighed down so it does not become displaced during heavy rain/runoff.
 - Turn ends of filter sock up slope, a minimum of 3 feet, to prevent flow around ends.
 - Compost filter socks must be in continuous contact with the ground. There should be no gaps between the sock and the ground beneath it.
- Compost filter socks may also be used for areas of concentrated flow such as near, but not at or in, streams or shorelines. Compost filter socks cannot be used in-water and must be installed above the high water mark for streams/shorelines.
- Material and equipment must not be stored on top of the compost filter socks while in place. The compost filter sock must always be accessible for inspection and maintenance.



Compost filter socks must be overlapped 6 inches minimum (or in accordance with the manufacturer’s recommendations), not abutted, when more than 1 compost filter sock is placed in a row.



Follow manufacturer’s specifications on proper use for fiber rolls used as velocity dissipation devices on steep slopes.

Installation and Implementation Requirements *(continued)*

- When used as velocity dissipation devices on steep slopes, stake compost filter socks into a 2- to 4-inch-deep trench with a width equal to the diameter of the compost filter sock. Stakes must be driven at least 12 inches into the ground, while leaving a minimum stake height of 2 inches above the compost filter sock. Drive stakes through the center at the end of each compost filter sock and space apart 4 feet maximum on center.
- Follow manufacturer's specifications on proper use.
- At the completion of project, filter sock material, including the compost, shall be removed from the site and disposed of/reused properly. Fill and compact trenches once compost filter socks are removed.
- Material for compost berm/filter sock may be left at the site and used as a soil amendment, if approved by the Engineer. Material should be spread, not left in a clump or pile. The geotextile netting must be disposed of properly.

Considerations

- Do not install below the high water mark of streams/shorelines or in-water.
- Unsuitable for areas with concentrated runoff unless a low flow rate and small drainage area warrants use of a filter berm/sock. Compost filter socks should be installed per manufacturer's recommendations.
- Heavy vegetation must be removed to ensure close contact of compost with the ground surface.
- Difficult to move once saturated.
- Uneven terrain may restrict use of BMP.
- Heavy construction equipment and/or vehicles that run over compost filter socks can easily damage or impair the performance of the device.
- Soil may harden on the geotextile filter fabric, which will inhibit infiltration and proper effectiveness.
- Efficiency quickly decreases as sediment accumulates. Frequent maintenance is needed.
- Berms/socks cannot be staked or trenched when used on concrete and rocky surfaces.

What to Inspect

- Does the filter sock have rips or tears exposing the filter media?

What to Inspect *(continued)*

- Does the filter sock need to be trenched and staked?
- Has sediment accumulated to one-half the height of the berm? Are compost filter socks positioned in the correct orientation to effectively manage storm water? Is there evidence of rills or gullies forming under the compost berm?
- Is there vehicles or equipment stored on top of the berm?
- Are compost filter socks properly installed according to manufacturer’s specifications?

Maintenance

- Remove sediment which has accumulated to within one-half of the berm height.
- Replace disturbed or damaged areas of the berm.
- Repair/replace split, torn or slumping compost filter socks.
- Repairs to damaged compost filter socks must preserve filtration capabilities. Do not use duct tape, glue, or any material that will diminish the effectiveness of the compost filter sock.
- Maintain BMP until the disturbed area above the device is permanently stabilized.
- Reorient compost filter socks that have been disturbed.
- Clean hardened soil on geotextile filter fabric to ensure proper filtration can occur.
- Fix berms/socks that have been driven over and flattened.



Repair/replace split, torn, or slumping compost filter socks to preserve filtration capabilities.

Compost Filter Berm/Sock

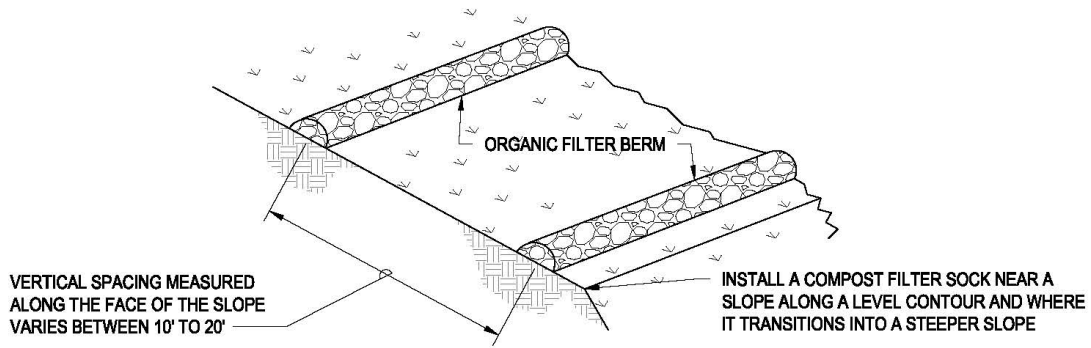

PERSPECTIVE
NOT TO SCALE

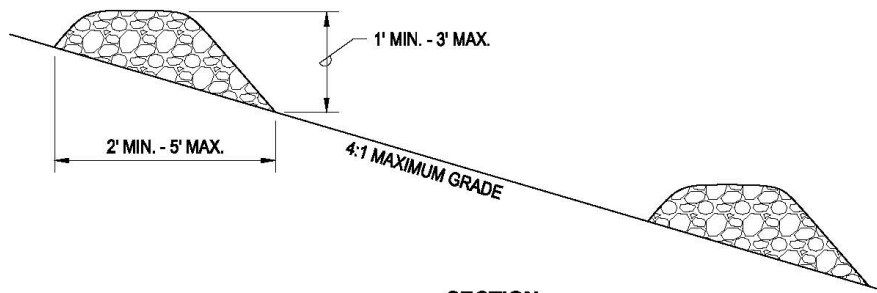

SECTION
NOT TO SCALE

COMPOST FILTER BERM

Compost Filter Berm/Sock

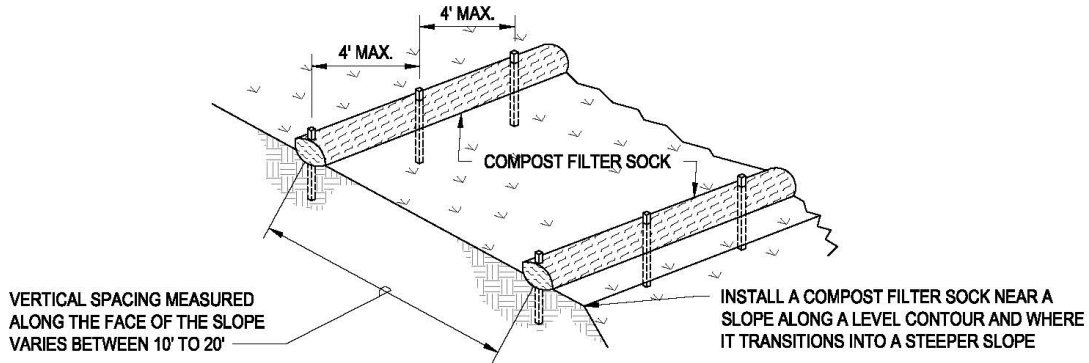

PERSPECTIVE
NOT TO SCALE

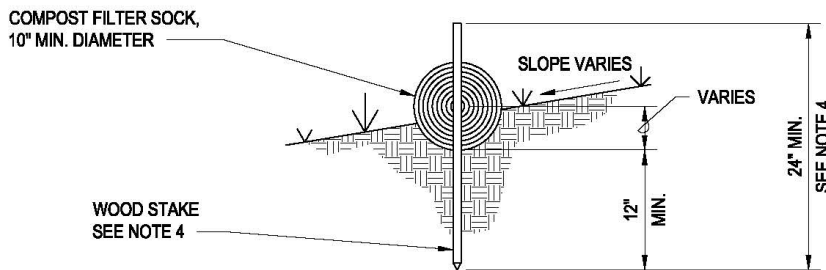

SECTION
NOT TO SCALE

NOTES:

1. COMPOST FILTER SOCKS SHOULD BE EITHER PREFABRICATED OR ASSEMBLED AT SITE.
2. LOCATE COMPOST FILTER SOCKS ON LEVEL CONTOURS SPACED AS FOLLOWS:
 - a. SLOPE INCLINATION OF 4:1 (H:V) OR FLATTER: COMPOST FILTER SOCKS AND/OR BERMS SHOULD BE PLACED AT A MAXIMUM INTERVAL OF 20 FT.
 - b. SLOPE INCLINATION BETWEEN 4:1 AND 2:1 (H:V): COMPOST FILTER SOCKS (USE OF BERMS NOT RECOMMENDED) SHOULD BE PLACED AT A MAXIMUM INTERVAL OF 15 FT. (A CLOSER SPACING IS MORE EFFECTIVE).
 - c. SLOPE INCLINATION OF 2:1 (H:V) OR GREATER: COMPOST FILTER SOCKS SHOULD BE PLACED AT MAXIMUM INTERVAL OF 10 FT.
3. TURN THE ENDS OF THE COMPOST FILTER SOCKS UP SLOPE TO PREVENT RUNOFF FROM GOING AROUND THE ROLL.
4. STAKE COMPOST FILTER SOCKS WITH STAKES WITH A MINIMUM LENGTH OF 14 IN. AND SPACED 4 FT. ON CENTER, OR AS RECOMMENDED BY THE MANUFACTURER, WHICHEVER IS GREATER.
5. IF MORE THAN ONE COMPOST FILTER SOCKS IS PLACED IN A ROW, THE ROLLS SHOULD BE OVERLAPPED, NOT ABUTTED.

COMPOST FILTER BERM (FILTER SOCK)

Compost Filter Berm/Sock

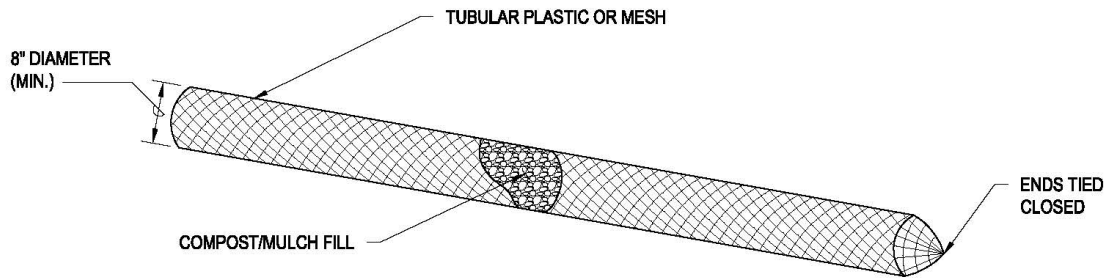

COMPOST FILTER BERM (FILTER SOCK)
NOT TO SCALE

Silt Fence or Filter Fabric Fence



Description

Temporary linear sediment barrier composed of permeable fabric designed to intercept and slow sediment-laden storm water.

Applications

- Install along the site perimeter.
- Install around temporary spoil or stockpiles.
- Install along streams and channels.
- Position below the toe of cleared or erodible slopes.
- Protect downslope of exposed soil areas.
- Place along the top of slope or other areas to reduce effects of sheet flow.

Installation and Implementation Requirements

- Install silt fence along or parallel to contours.
- Excavate a trench 6 inches wide and 6 inches deep along the line of the silt fence (soil slicing may be considered).
- Place the bottom of the silt fence in the trench.
- Backfill the trench and compact the soil by hand or mechanically.
- Silt fence posts shall be wooden, 1.25-inch × 1.25-inch × 48-inch, and be driven a minimum of 14 inches into the trench (*see* silt fence detail). Posts shall be installed on the down slope side of the silt fence. Silt fence posts may be attached to the fabric on-site or silt fence with pre-attached posts may also be used.

Installation and Implementation Requirements *(continued)*

- Silt fence products using steel rebars in lieu of wood posts must use #4 or larger rebar and must include a safety cap on all exposed edges.
- Silt fence must be overlapped 6 inches between adjoining segments or may be overlapped, wrapped, and rolled.
- Ends of silt fence shall be turned uphill.
- Primarily used where sheet flow occurs.
- When using 2 rows of silt fence, install far enough apart to prevent the collapse of 1 fence from impacting the other.
- Install silt fence according to the specifications listed above or per manufacturer's specifications, whichever is more stringent.



Properly installed silt fences are overlapped between adjoining segments or are overlapped, wrapped, and rolled.

Considerations

- Avoid installing silt fence on slope. However, if silt fence is placed on a slope, fence posts may need additional embedment.
- Do not install in streams, channels, or areas of concentrated flow.
- Do not use to divert flow.

What to Inspect

- Is there sediment accumulating behind the silt fence?
- Is the silt fence properly installed?
- Is there evidence of undermining or undercutting?
- Are adjoining segments seamless?
- Does silt fence have rips, tears, or degradation of fabric?
- Are stakes on downgradient side?
- Is the fabric securely attached to the stakes?



Silt fences must be trenched in a trench 6 inches wide and 6 inches deep, backfilled, and compacted.

Maintenance

- Repair or replace damaged fence or posts.
- Repair or replace split, torn, slumping, or weathered silt fence.
- Repair or reinstall silt fence where undercutting has occurred.
- Remove accumulated sediment when depth reaches one-third the barrier height.
- Maintain vegetative ground cover upstream of the silt fence. Bare soil upstream of the silt fence can increase frequency and possibility of silt fence failure.



Repair or reinstall silt fence where undercutting has occurred.

Silt Fence or Filter Fabric Fence

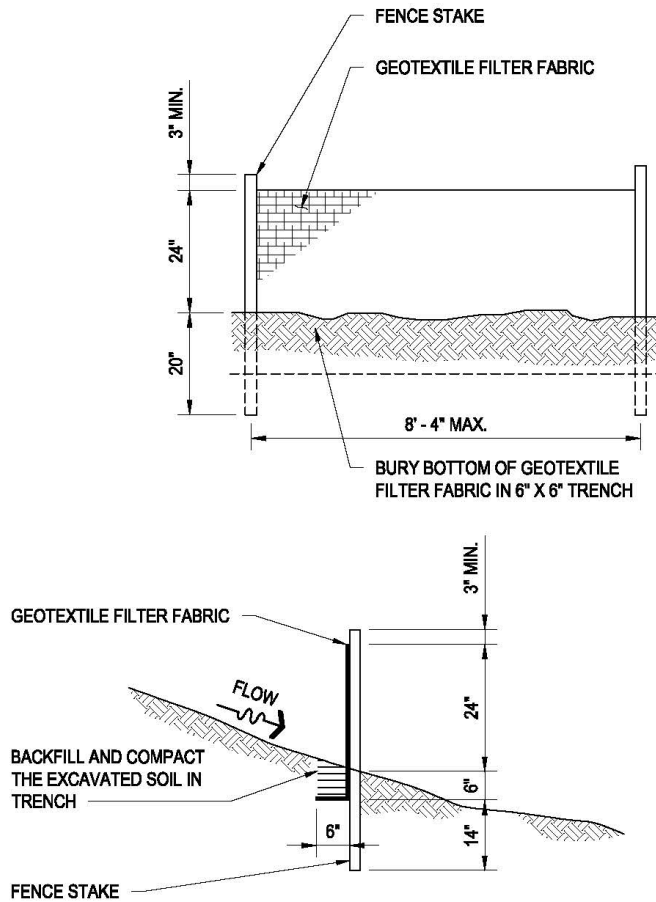

NOTES:

1. THE FILTER FABRIC SHALL BE A MINIMUM OF 36 INCHES WIDE.
2. IF SILT FENCE IS OBTAINED FROM MANUFACTURER AS A PACKAGE (I.E. FABRIC ATTACHED TO POST) THE MANUFACTURER'S INSTALLATION INSTRUCTION SHALL BE ADHERED TO.
3. FENCE STAKE MAY BE WOOD OR METAL, MUST BE CAPABLE OF SUPPORTING ANTICIPATED LOADS.
4. SILT FENCE MUST BE OVERLAPPED 6" BETWEEN ADJOINING SEGMENTS OR MAY BE OVERLAPPED, WRAPPED, AND ROLLED.

SILT FENCE
NOT TO SCALE

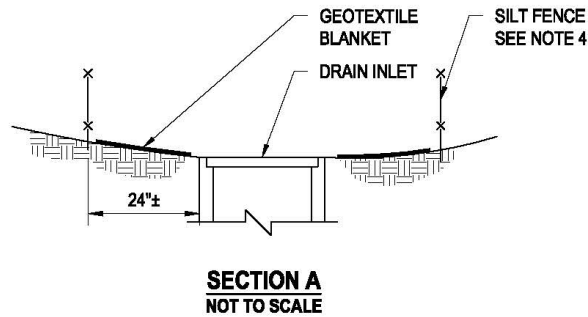
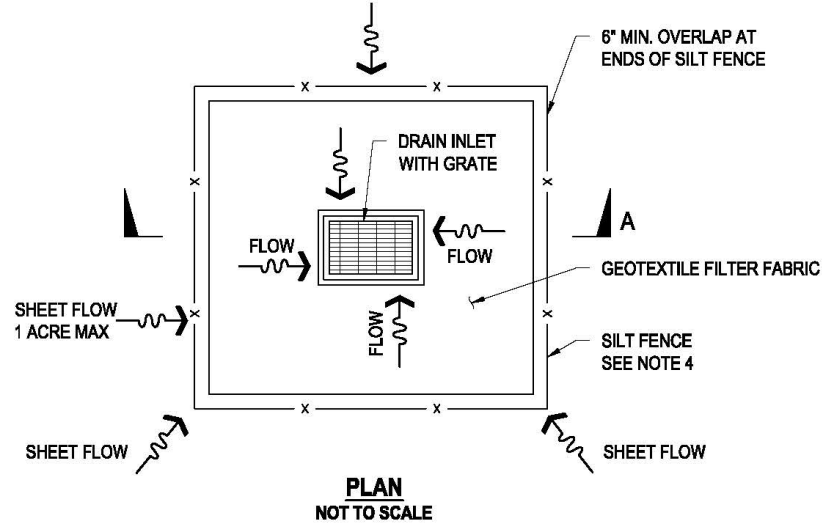

NOTE:

1. FOR USE IN AREAS WHERE GRADING HAS BEEN COMPLETED AND FINAL SOIL STABILIZATION AND SEEDING ARE PENDING.
2. NOT APPLICABLE IN PAVED AREAS.
3. NOT APPLICABLE IN CONCENTRATED FLOWS.
4. REFER TO BMP SC-7, SILT FENCE OR FILTER FABRIC FENCE.

GEOTEXTILE FILTER FABRIC FENCE FOR DROP INLET FILTER



Description

Device used to intercept sediment-laden sheet flow, and allow sediment to settle prior to discharging off-site.

Applications

- Along the site perimeter.
- Along streams and channels.
- Utility trench barriers in channels.
- Across swales and small catchments.
- Diversion dike or berm.
- Below toe of exposed slopes.
- Temporary sediment trap.
- Around stockpiles.
- Weigh down inlet protection devices.



Sandbag barriers intercept sediment-laden sheet flow and allow sediment to settle prior to discharging off-site.

Installation and Implementation Requirements

- Install bags end-to-end along a level contour.
- Turn ends of sandbag barrier up slope to prevent flow around ends.
- May be used in combination with soil stabilization controls up slope.

Installation and Implementation Requirements *(continued)*

- Stack sandbags cross-sectionally in a pyramid formation if bags are to be stacked higher than 2 bags. If additional reinforcement is used, then stack sandbags in a brick wall formation.
- Materials for sandbag barrier shall comply with the following:
 - Sandbag shall be woven polypropylene or polyamide fabric with ultraviolet protection to avoid rapid deterioration of fabric.
 - Bag dimensions can vary but must be able to withstand anticipated flows.
 - Fill material shall consist of non-cohesive, permeable material free of fines from clay and deleterious material.
- Sandbag barriers are allowed to be used in-stream provided that they will not become flood hazards, sandbag contents do not leak into the stream bottom, and they are removed once the project is completed.



Sandbags may be stacked in a brick wall-like formation if additional reinforcement is used.

Considerations

- Drainage area shall not exceed 5 acres.
- Avoid installing at locations which may compromise traffic safety.
- Burlap material shall not be used for sandbags.
- Does not filter sediment.
- Bags degrade when exposed to sunlight.
- Not adequate for long-term projects.
- Depending on application, installation may require an adequate amount of manpower.
- Not ideal for concentrated flows.

What to Inspect

- Has sediment accumulated?
- Does the sandbag have tears or rips?
- Are sandbags evenly spaced to weigh down inlet protection?
- Does the sandbag need to be replaced or reoriented?

What to Inspect *(continued)*

- Is there evidence of erosion undermining the sandbag barrier?
- Is water bypassing the sandbag barrier?

Maintenance

- Reshape or replace sandbags as necessary.
- Remove and properly dispose of sediment, which has accumulated to a depth of 6 inches.
- Remove sandbags if they are no longer in use. If the area needs to be stabilized, do so immediately after removal.



Ensure that disturbed sandbags are reshaped or replaced as necessary.

Sandbag Barrier

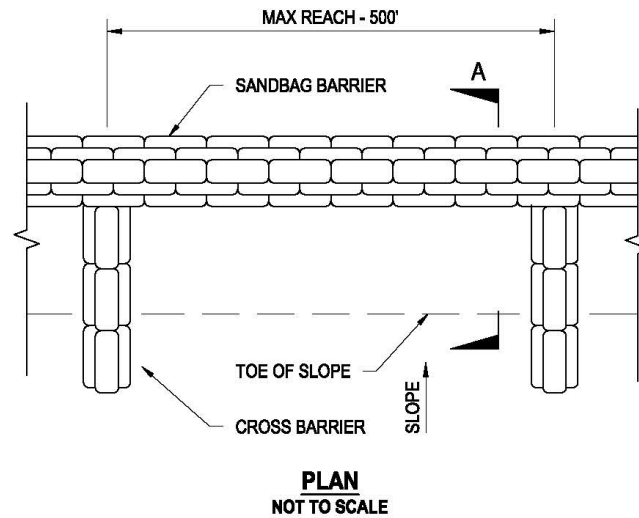

NOTES:

1. CONSTRUCT THE LENGTH OF EACH REACH SO THAT THE CHANGE IN BASE ELEVATION ALONG THE REACH DOES NOT EXCEED 1/2 THE HEIGHT OF THE LINEAR BARRIER.
2. IN NO CASE SHALL THE REACH LENGTH EXCEED 500 FEET.
3. PLACE SANDBAGS TIGHTLY.
4. DIMENSIONS MAY VARY TO FIT FIELD CONDITIONS.
5. SANDBAG BARRIER SHALL BE A MINIMUM OF 3 BAGS HIGH.
6. THE END OF THE BARRIER SHALL BE TURNED UP SLOPE.
7. CROSS BARRIERS SHALL BE A MIN OF 1/2 AND A MAX OF 2/3 OF THE HEIGHT OF THE LINEAR BARRIER.
8. SANDBAG MATERIAL MUST CONFORM TO ASTM D3786 AND ASTM D4355.
9. SANDBAG BARRIERS ARE ALLOWED IN -STREAM PROVIDED THAT THEY WILL NOT BECOME FLOOD HAZARDS, SANDBAG CONTENTS DO NOT LEAK, AND THEY ARE REMOVED ONCE THE PROJECT IS COMPLETED.

SANDBAG BARRIER

Sandbag Barrier

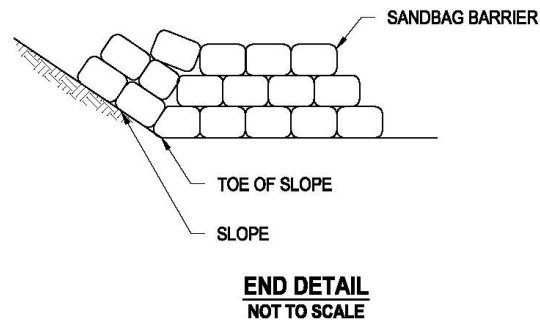
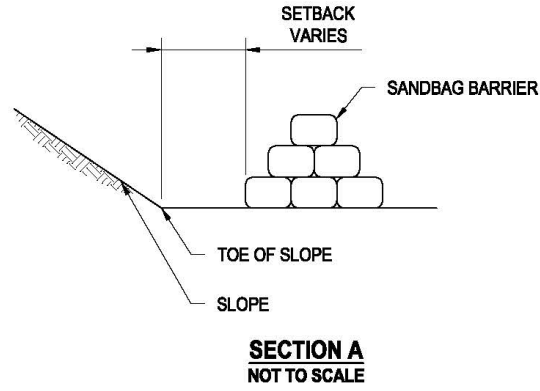

SANDBAG BARRIER

Brush or Rock Filter



Description

Filter berms constructed of brush or rock placed across a level contour area where sheet flow may occur to trap sediment and reduce flow velocity.

Applications

- Check dams across construction roads with mild slopes.
- Below the toe of slopes.
- Along the site perimeter, streams, or channels.
- Around temporary spoil areas.
- Downstream of small cleared areas.
- Sediment traps at culvert or pipe outlets.

Installation and Implementation Requirements

- Use stones between 0.75 to 3 inches in diameter or brush wrapped in geotextile filter fabric. Brush from site clearing may be used. Place across areas of sheet flow.
- Installation of rock filter berms with geotextile filter fabric should be used when possible.
- A brush filter berm can be made of brush, small tree limbs, grass, leaves or other waste material from clearing and grubbing.
- Brush filter berms must be 2 to 5 feet in height to detain storm water. The base width of the berm must be 5 to 10 feet with a shape that is either a triangle or slightly rounded.

Installation and Implementation Requirements *(continued)*

- Install filter 5 to 7 feet from toe of slope to allow ponding.
- Larger rocks must be placed as the base of the berm. Smaller rocks must be placed on the uphill side to form a natural filter.
- Place larger rocks without fines in a gabion to stabilize areas of concentrated flow.
- Use larger stones placed in staked and woven wire sheathing if stones are used across an area of concentrated flow.
- Construct along a level contour.
- Provide an area behind berm for detention and sedimentation.
- Geotextile filter fabric, rope, or wire mesh screen can be used to keep the shape of the berm intact.
- Install the geotextile filter fabric into a 6-inch-deep trench uphill from berm.
- Secure filter fabric with staples, stakes, or rope to protect the brush from being displaced from wind or a storm.

Considerations

- Adequate detention area behind berm is necessary to prevent flooding upstream.
- Drainage area shall not exceed 5 acres.
- Removal of stone berms may be difficult, resulting in limited usefulness in landscaped areas.
- Must not be used in continuously flowing streams.
- Ponding may occur if not sized properly.

What to Inspect

- Has rock or brush been displaced?
- Is ponding occurring in undesired areas?
- Is there evidence of erosion or sheet flow?
- Is the height and width of the device appropriate for the flow?

Maintenance

- Reshape berm and replace any missing or dislodged stone or brush.
- Remove and dispose of sediment on upstream site of filter upon reaching a depth of 6 inches.
- Replace geotextile filter fabric when tears and rips limit effectiveness.

Brush or Rock Filter

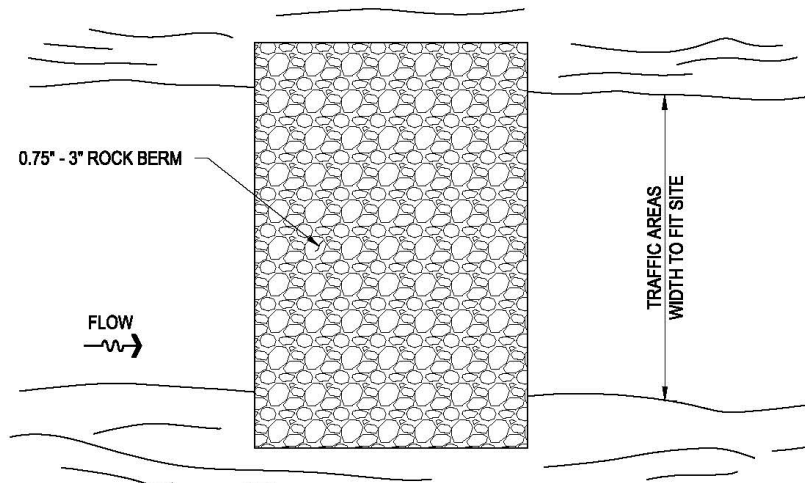

PLAN
NOT TO SCALE

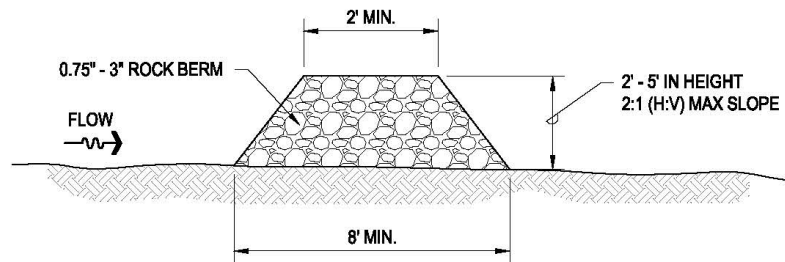

SECTION
NOT TO SCALE

BRUSH OR ROCK FILTER

Construction Road and Parking Lot Stabilization



Description

Stabilization and maintenance of temporary construction roads and parking areas after grading to minimize erosion and dust from vehicular traffic.

Applications

- Temporary construction roads.
- Parking areas for construction equipment and vehicles.
- On-site vehicular routes.
- Areas where sediment tracking may be a problem during wet weather.
- Areas where dust may be a problem during dry weather.
- Areas adjacent to bodies of water.
- Along steep grades or areas where additional traction is necessary.

Installation and Implementation Requirements

- Grade roadway to follow topographic contours to reduce erosion and divert surface water off the roadway.
- Roadway grade shall not exceed 15%.
- Properly grade roadway to prevent runoff from leaving site.
- Stabilize the temporary construction roads and parking areas with aggregate, asphalt cement, or concrete.

Construction Road and Parking Lot Stabilization

Installation and Implementation Requirements *(continued)*

- The aggregate layer shall be a minimum of 4 inches deep. The base shall consist of HDOT approved 2- to 3-inch coarse aggregate and shall be applied immediately after grading.
- Place geotextile filter fabric beneath the aggregate.
- Consider existing storm water flows when designing construction roads or parking areas. Remove or convert to permanent roadway upon completion of construction.
- Does not replace requirements for a construction entrance/exit.



Aggregate used to stabilize temporary construction roads and parking areas must be 2 to 3 inches in size.

Table SC-10.1 Allowable and not allowable materials used for temporary construction roads and parking areas.

Allowable Materials	Not Allowable Materials
<ul style="list-style-type: none"> • Aggregate • Concrete • Asphalt cement • Compacted base course 	<ul style="list-style-type: none"> • Cold mix asphalt • Uncompacted and compacted asphalt cement grindings • Crushed concrete • Concrete-treated Base

Considerations

- Although allowed under certain circumstances by the *2005 Hawaii Standard Specifications for Road and Bridge Construction*, whenever possible, avoid chemicals stabilization methods, which may contribute to soil pollution and increase runoff.
- Construction traffic management may be subject to air quality control measures. Contact the local air quality management agency for more information.
- Roadway grade and site conditions.

What to Inspect

- Is there sediment buildup within aggregate?
- Is there dust generated from vehicles traveling on construction roads?



Construction Road and Parking Lot Stabilization

What to Inspect *(continued)*

- Is the proper aggregate type and size being used?
- Is there geotextile under the coarse aggregate?
- Is there evidence of tracking on public roads?

Maintenance

- Periodically apply additional aggregate to refresh void spots on construction roads and parking areas.
- Remove sediment on the aggregate periodically to minimize polluted runoff.
- Temporary construction roads may require frequent dust control.
- Reshape roadway as needed for drainage and runoff control.



Description

Designated areas for entry and/or exit from a construction site to reduce the amount of sediment tracked off-site by construction vehicles.

Applications

- Stabilized construction entrances/exits shall be used at all points where access to a construction site from paved roads is required.

Installation and Implementation Requirements

- Restrict vehicle use to properly designated entrance/exit points.
- Grade the stabilized entrance/exit to prevent runoff from discharging off-site. Construct stabilized entrance/exit on level ground where possible.
- Provide ample turning radii, when applicable.
- Coarse aggregate, that are free of fine material, shall be 3 to 6 inches in diameter. The use of crushed concrete and asphalt concrete millings/grindings are not allowed.
- Depth of aggregate shall be 12 inches or as recommended by the Soils Engineer. Contractor is responsible to design stabilized construction entrance/exit to support heaviest vehicles and equipment that will use it.



Aggregate depth of rock construction entrances must be 12 inches deep with geotextile filter fabric beneath the aggregate.

Installation and Implementation Requirements *(continued)*

- Place geotextile filter fabric beneath the 12-inch-deep layer of aggregate.
- Dimensions shall be a minimum of 50 feet in length and 30 feet in width. If project site layout will not accommodate minimum dimensions, install additional BMPs to remove sediment from the vehicles prior to entering/exiting the site.
- Alternative commercial construction entrance/exit products may be used in lieu of aggregate if approved by the Engineer and installed per manufacturer’s specifications.
- Installation of a stabilized entrance/exit is required if ground-disturbing activity will occur and exiting the construction site onto paved roads and sidewalks is needed.
- A tire wash can be incorporated with a stabilized construction entrance/exit to assist with the removal of sediment from construction vehicles.
 - The tire wash must be designed for the anticipated traffic load and located a minimum of 50 feet from a state water.
 - Automatic shutoff nozzles must be used to avoid wasting water.
 - The wash waters must be retained on the project site and drain to a properly constructed sediment trap or similar device.
- Sediment tracked onto adjacent roadways or paved areas shall be removed by the end of the same day that the tracking occurred or immediately when sediment is tracked more than 50 feet from the construction entrance/exit, whichever occurs sooner.
- Use dry methods to remove the sediment from the adjacent roadways or paved areas. This includes, but is not limited to, mechanical street sweepers, brooms, shovels, vacuums, or other similarly effective methods. The sediment collected shall be removed or stabilized on-site.
- The pavement shall not be cleaned by washing down the street into any storm water conveyance (unless it’s connected to a sediment basin, sediment trap, or similarly effective control), storm drain inlet, or state water.
- Limit points of entry onto the construction site to minimize possible areas of tracking.



Alternative commercial construction entrance/exit products may be used if approved by the Engineer and installed per manufacturer’s specifications.

Considerations

- Surface aggregate shall be periodically replenished.

Considerations *(continued)*

- If the construction exit is not preventing sediment from being tracked onto the pavement, consider increasing the dimensions of the entrance, and/or installing a tire wash.
- A sediment trapping device is required if a tire wash is used in conjunction with the stabilized construction entrance/exit.
- The speed of the construction truck through the tire wash is crucial to the effectiveness of the cleaning. The slower the truck moves through the wash, the better the cleaning.
- A turnout or doublewide exit is required to prevent entering vehicles from driving through the tire wash area.
- Sediment accumulates between the aggregate and reduces the effectiveness of the construction entrance/exit.

What to Inspect

- Is sediment buildup evident within aggregate?
- Are commercial products being maintained to maximize effectiveness?
- Is there evidence of tracking onto paved roads?
- Is proper size and type of aggregate used?
- Is there geotextile installed beneath aggregate?
- Is the construction entrance/exit the correct dimensions?
- Is runoff leaving site?
- Is clean water being used for tire washing?



Sediment tracked onto adjacent roadways or paved areas must be removed using dry cleaning methods.

Maintenance

- Clean dirt, mud, or other material tracked onto the road, sidewalk, or other paved area by the end of the same day in which the trackout occurs.
- Remove aggregate, separate and dispose of sediment, when no longer in use.
- Perform street sweeping as needed. Washing of the roads to address sediment trackout is not permitted
- Adjust street sweeping schedule as needed.
- Replenish surface aggregate periodically.

Maintenance *(continued)*

- Remove accumulated sediment from the construction entrance/exit.
- Upon project completion, all construction entrances/exits shall be removed by the contractor and stabilized in accordance with the *2005 Hawaii Standard Specifications for Road and Bridge Construction and Special Provisions*, or other regulatory requirements.



Surface aggregate must be replenished periodically to ensure sediment does not overwhelm the construction entrance/exit.

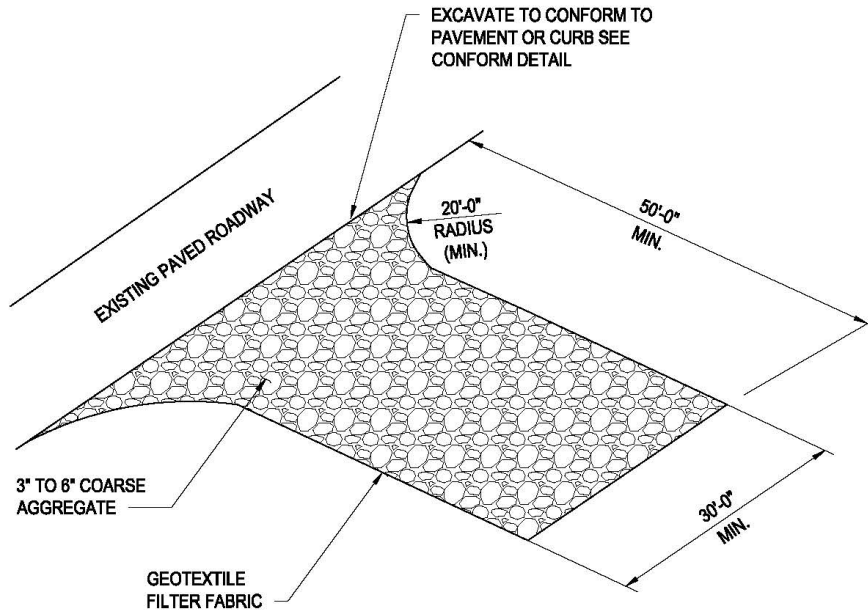

PERSPECTIVE
NOT TO SCALE

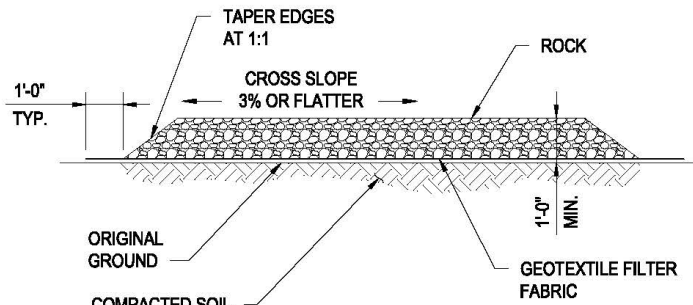

SECTION
NOT TO SCALE

STABILIZED CONSTRUCTION ENTRANCE

NOTES:

1. GEOTEXTILE FILTER FABRIC MUST BE INSTALLED BENEATH THE 12" DEEP LAYER OF AGGREGATE.

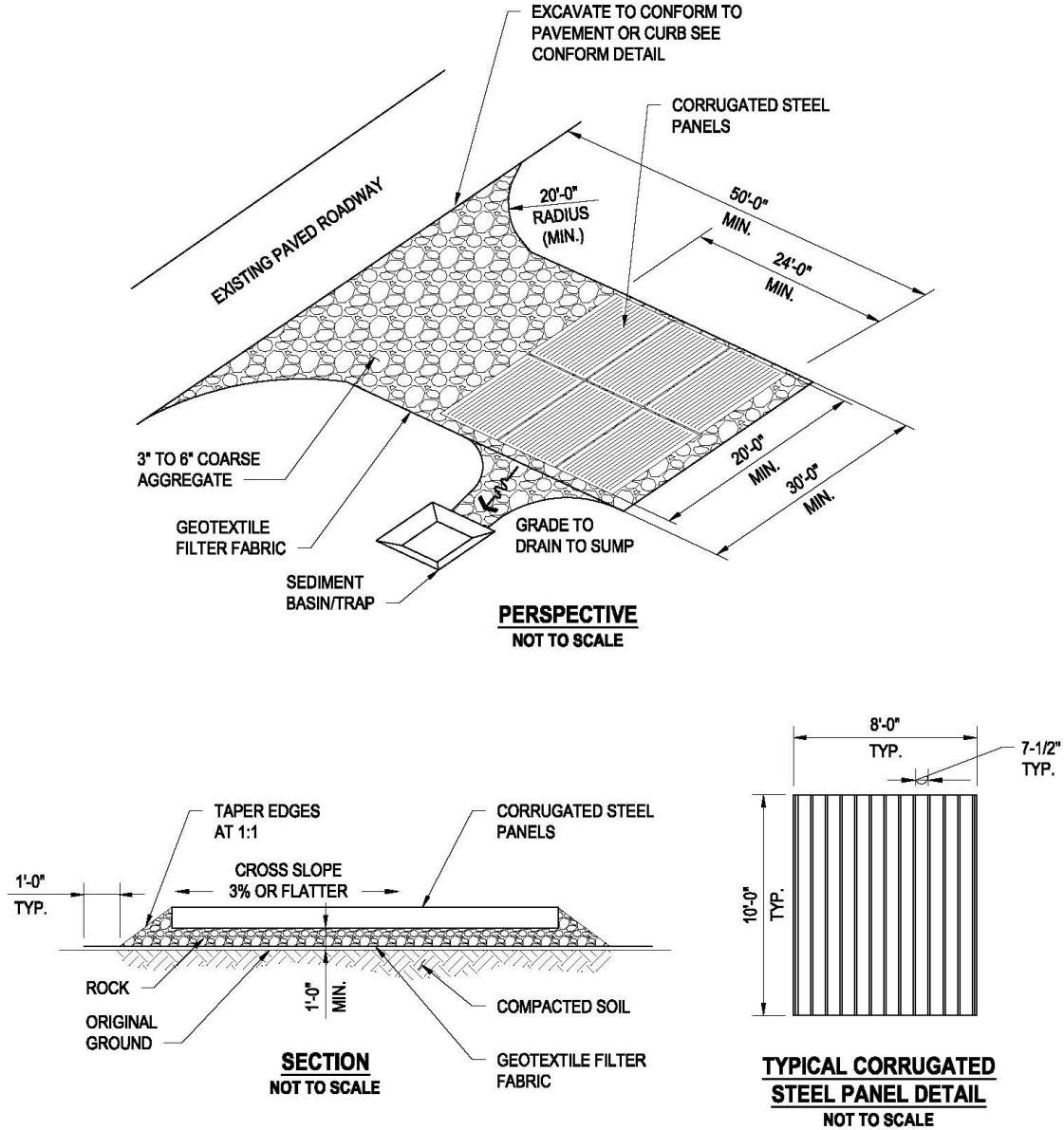

STABILIZED CONSTRUCTION ENTRANCE WITH CORRUGATED STEEL PLATES

NOTES:

1. GEOTEXTILE FILTER FABRIC MUST BE INSTALLED BENEATH THE 12" DEEP LAYER OF AGGREGATE.