

# Revised Storm Water Post-Construction Best Management Practices(BMP) Manual Workshop

May 18, 2022

Hawaii State Department of Transportation, Highways Division



# Storm Water Post-Construction BMP Manual

## REVISION

what

Provide procedures and guidelines to ensure that post-construction BMPs are considered and implemented, as applicable, throughout all phases of DOT-HWYS new development, redevelopment, and private construction projects.

when

The manual revision will be completed in November 2021 with an implementation date in 2022 to be determined. DOT-HWYS will conduct a training event prior to implementation of the revised manual.

how

After the implementation date, designers and design reviewers, will be required to comply with the criteria for the implementation and the design standards provided in the revised manual.

why

- General organizational changes to the structure of the manual to increase clarity and improve usability.
- Separate post-construction BMP criteria for areas covered under an MS4 NPDES Permit and more rural areas that are not covered under a permit.
- Revised criteria for MS4 NPDES Permit areas to increase the implementation of post-construction BMPs, prioritizing LID BMPs.
- Revised evaluation process to determine whether a project qualifies for a variance from LID BMP requirements or an exemption from post-construction BMPs.
- An Alternative Compliance process for projects in which the full required treatment area cannot be addressed by post-construction BMPs.

Storm Water Post-Construction  
Best Management Practices Manual



**PROTECT  
OUR WATER**  
MĀLAMA I KA WAI  
STATE OF HAWAII DEPARTMENT OF TRANSPORTATION



State of Hawaii  
Department of Transportation  
Highways Division  
December 2021

The revised manual is available  
for download at:

[stormwaterhawaii.com](https://stormwaterhawaii.com)

The Effective Date of the revised  
manual is **July 1, 2022**

# STORM WATER POST-CONSTRUCTION BMP MANUAL SECTIONS

**1. ENVIRONMENTAL BACKGROUND  
AND INTRODUCTION**

**2. STORM WATER POST-CONSTRUCTION  
BEST MANAGEMENT PRACTICES**

**3. CRITERIA FOR MS4  
PERMIT AREAS**

**4. CRITERIA FOR NON-MS4  
PERMIT AREAS**

**5. EXEMPTIONS AND VARIANCES**

**6. ALTERNATIVE COMPLIANCE**

**7. POST-CONSTRUCTION BMP  
DESIGN METHODOLOGY**

**8. POST-CONSTRUCTION BMP  
DEVELOPMENT IN PLANNING PHASE**

**9. POST-CONSTRUCTION BMP  
DEVELOPMENT IN DESIGN PHASE**

**10. INSPECTIONS, OPERATION,  
AND MAINTENANCE**

# POST-CONSTRUCTION (PERMANENT) BMPs & LID

## **Post-Construction Best Management Practice (BMP):**

A specific practice intended to reduce storm water volume and/or the pollution typically associated with storm water runoff. Such practices may include LID design features, source control methods, or manufactured devices designed to capture pollutants and is synonymous with the terms Permanent BMP (PBMP) and Permanent Post-construction BMP.

## **Low Impact Development (LID):**

A comprehensive land planning and engineering design approach with a goal of maintaining and enhancing the pre-development hydrologic regime of urban and developing watersheds.

# Public vs Private Construction Projects

(Previously “Contract”)

(Previously “Encroachment”)



**REVISED!**

**PUBLIC CONSTRUCTION PROJECT** – A project funded by DOT-HWYS, designed by personnel of DOT-HWYS or engineering consultant firms, and constructed by DOT-HWYS or a private contractor.

**PRIVATE CONSTRUCTION PROJECT** – A project not under the authority (funding) of or administered by DOT-HWYS that is located within or adjacent to DOT-HWYS right-of-way and drains to the DOT-HWYS MS<sub>4</sub>. Not necessarily a privately-funded project, also includes projects funded by the City and County of Honolulu and other counties. Private construction projects are required to obtain a Permit to Perform Work Upon State Highways. Private construction projects that drain to the DOT-HWYS MS<sub>4</sub> are required to submit an Application for a Private Storm Drain Connection and/or Discharge Permit to the State of Hawaii Highways Division Storm Drain System and a Permit to Discharge into the State Highways Drainage System. Also known as an Encroachment Permit Project or Encroachment Contract project.

# LID Treatment Control BMP Examples

- Vegetated Buffer Strip
- Vegetated Swale
- Enhanced Swale
- Infiltration Trench
- Infiltration Basin
- Bioretention Facility
- Permeable Pavement
- Pocket Wetland
- Rainwater Harvesting
- Tree Box Filter



# LID Treatment Control BMPs



Bioswale or “Enhanced Swale”

# LID Treatment Control BMPs



“Treatment Train”

# Non-LID Treatment Control BMP Examples

- Wet Pond
- Sand Filter
- Wet Extended Detention Pond
- Drain Inlet Filter
- Modified Catch Basin
- Oil/Grit Separator
- Centrifugal Hydrodynamic Separator
- Multi-Stage Hydrodynamic Separator

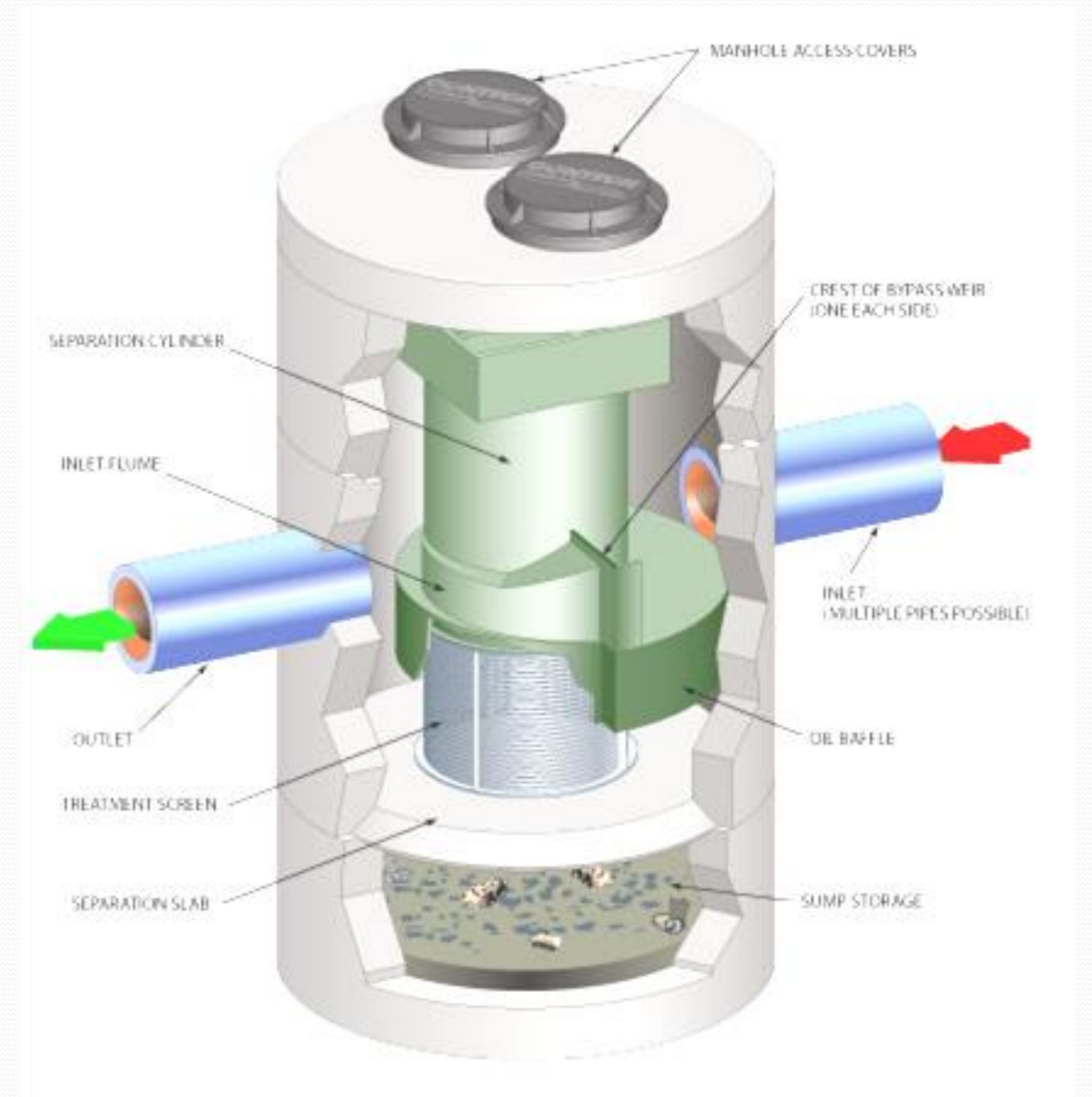

Continuous Deflection Separator (CDS) Unit

# Non-LID Treatment Control BMPs

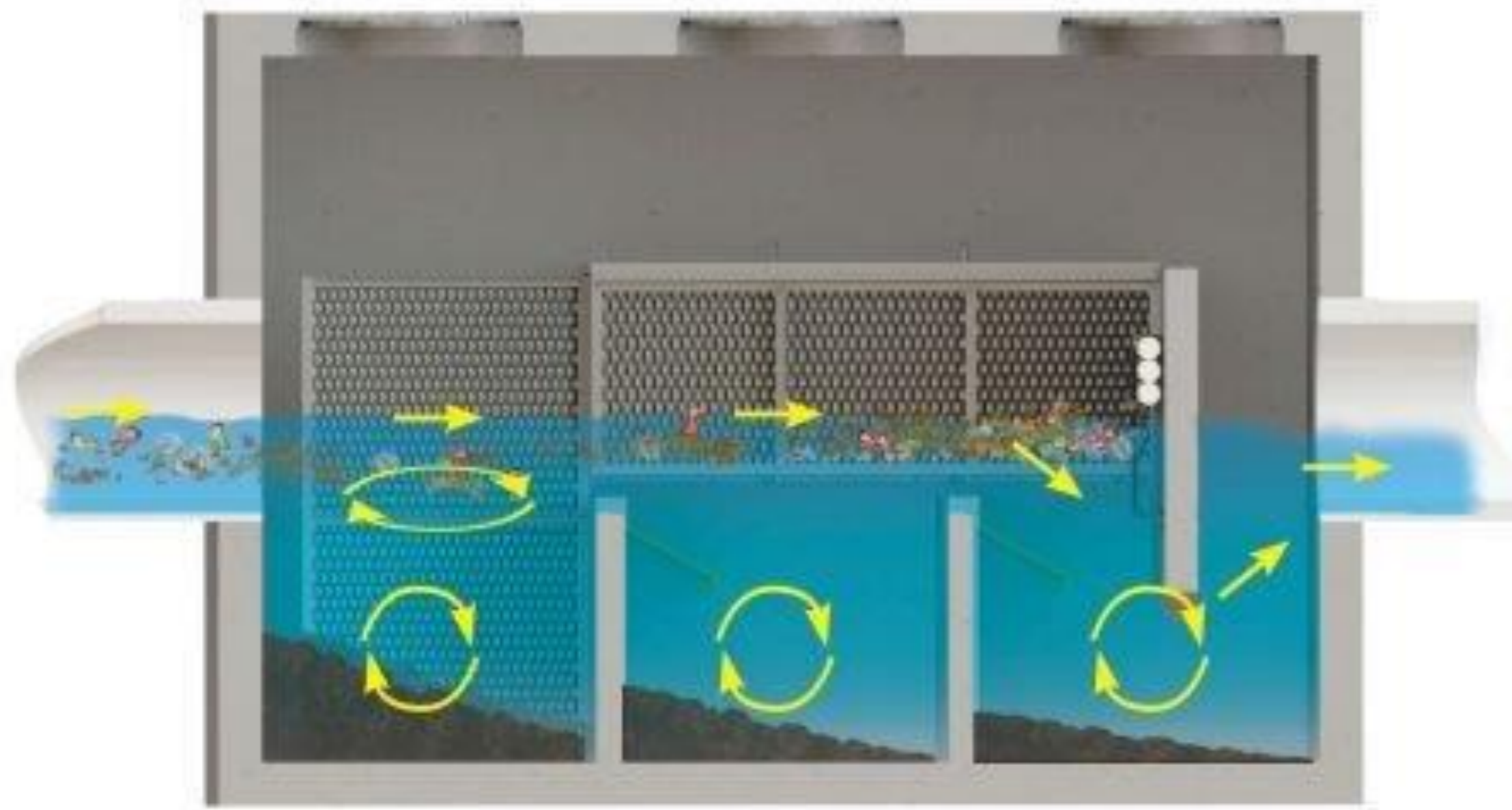

Debris Separating Baffle Box (DSBB)

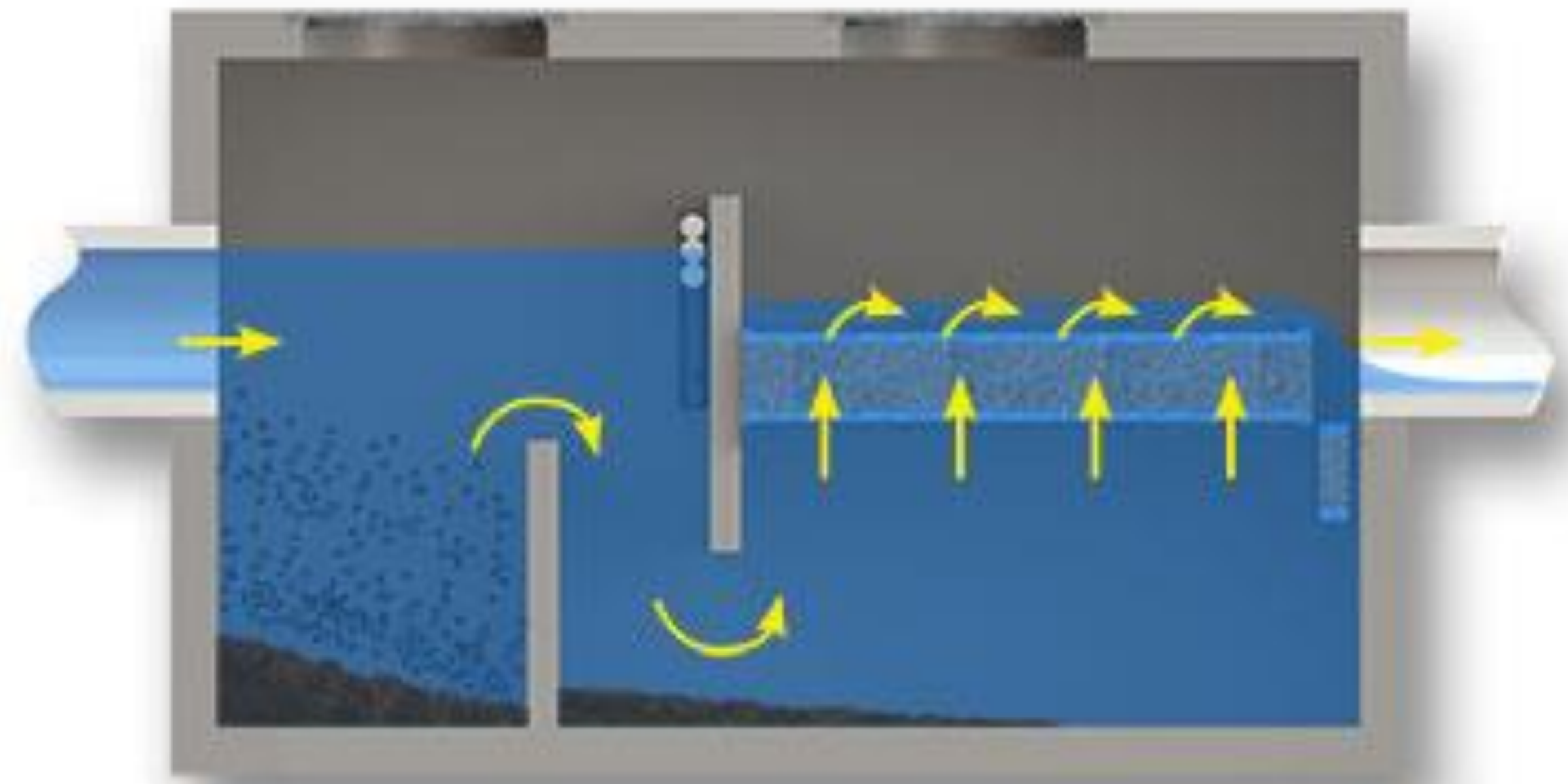

Water Polisher with Media Filter

# Non-LID Treatment Control BMPs



Downspout Filter Box



Curb Inlet Screen Guard

# Source Control BMPs

Management techniques and tools that reduce storm water runoff and pollutants at the source:

- Land Management Techniques
- Soil Stabilization Methods
- Sediment Control Methods
- Storm Water Flow Control Methods
- Trash Management Practices
- Good Housekeeping Measures
- Spill Prevention Techniques

# Appendix A

## Treatment Control Best Management Practices

Table A-1. Post-Construction BMP Summary Matrix

<u>APPENDIX</u>	<u>TITLE</u>	<u>PAGE</u>
A.	Treatment Control Best Management Practices	
	LID TREATMENT CONTROL BMPs	
	Vegetated Buffer Strip .....	A-4
	Vegetated Swale .....	A-9
	Enhanced Swale .....	A-15
	Infiltration Trench .....	A-21
	Infiltration Basin .....	A-27
	Bioretention Facility .....	A-33
	Permeable Pavement .....	A-40
	Pocket Wetland .....	A-46
	Rainwater Harvesting .....	A-54
	Tree Box Filter .....	A-60
	TRADITIONAL NON-LID TREATMENT CONTROL BMPs	
	Wet Pond .....	A-66
	Wet Extended Detention Pond .....	A-73
	Sand Filter .....	A-79
	PROPRIETARY NON-LID TREATMENT CONTROL BMPs	
	Drain Inlet Filter .....	A-87
	Modified Catch Basin .....	A-89
	Oil and Grit Separator .....	A-91
	Centrifugal Hydrodynamic Separator .....	A-93
	Multi-Stage Hydrodynamic Separator .....	A-95

Treatment Control BMP	Typical Targeted Pollutants for Removal						Notes	
	Sediment <sup>1</sup>	Nutrients <sup>1</sup>	Oil & Grease <sup>2</sup>	Metals <sup>1</sup>	Trash <sup>2</sup>	Bacteria <sup>1</sup>		
LID	Vegetated Buffer Strip	x		x		x		
	Vegetated Swale	x		x		x		
	Enhanced Swale	x	x	x	x	x		
	Infiltration Trench	x	x	x	x	x	x	
	Infiltration Basin	x	x	x	x	x	x	
	Bioretention Facility	x	x	x	x	x	x	
	Permeable Pavement	x	x	x	x		n/a	
	Pocket Wetland	x	varies	x	x	x	x	
	Rainwater Harvesting	varies	varies	n/a	varies	n/a	varies	Primarily for runoff reduction
	Tree Box Filter	x	x	x	n/a	x	x	
TRADITIONAL NON-LID	Wet Pond	x	x	x	x	x	x	
	Wet Extended Detention Pond	x	x	x	x	x	x	
	Sand Filter	x	varies	x	x	x		
PROPRIETARY NON-LID	Drain Inlet Filter	x				x		
	Modified Catch Basin	x				x		
	Oil/Grit Separator	x		x	n/a	x	n/a	
	Centrifugal Hydrodynamic Separator	x		x	x	x		
	Multi-Stage Hydrodynamic Separator	x		x	x	x		

<sup>1</sup> Source: State of Georgia Stormwater Management Manual 2016

<sup>2</sup> Source: North Carolina DOT 2020

# Appendix A



## Enhanced Swale

T-3



H-1 Freeway Eastbound Onramp Cloverleaf, Mo'ili'i, Hawaii

### Typical Targeted Pollutants for Removal

Sediment	x
Nutrients	x
Oil & Grease	x
Metals	x
Trash	x
Bacteria	

### Other Considerations <sup>1</sup>

Construction Cost	Low to Moderate
Maintenance Cost	Low to Moderate
Effective Life	5-20 years

<sup>1</sup> Source: Washington State DOT, Highway Runoff Manual 2019

### Description & Purpose

An enhanced swale may look similar to a vegetated swale at the surface but features a permeable planting media beneath the swale bottom to allow for capture and treatment of the Water Quality Volume. Also referred to as a bioretention swale or bioswale, an enhanced swale functions similarly to a bioretention facility but also provides storm water conveyance.

### Applications

Enhanced swales are applicable for land uses such as roads, highways, residential development, and impervious areas. They are often installed parallel to roads or within medians and used for flow conveyance as well as water quality treatment and flow attenuation.

### Limitations

- Excessive oils and grease may hinder plant growth resulting in lower reduction of pollutants.
- Typically requires a pretreatment device upstream such as a sediment forebay, vegetated buffer strip, or level spreader.
- Flow velocities should not exceed 1 ft/sec for the water quality flow rate and 3 ft/sec for the design peak flow rate, respectively.
- Maintain at least 3 feet clearance between the bottom of the drainage layer and the seasonally high groundwater table.
- Ponding may create a breeding environment for mosquitoes.



## Enhanced Swale

T-3

### Design Criteria

#### SIZING PROCEDURE

1. Determine the Water Quality Volume (WQV).
2. Pretreatment is critical to capture sediment that may otherwise lead to premature failure of the facility. Size the pretreatment forebay assuming a volume equal to 10 percent of the WQV (DOEE 2020). The forebay volume counts toward the WQV requirement.

$$V_p = 0.1WQV$$

Where  $V_p$  = Pretreatment Forebay Volume (ft<sup>3</sup>)  
WQV = Water Quality Volume (ft<sup>3</sup>)

3. Select a design ponding depth ( $d_p$ ) and determine the thickness and porosity for the planting media and drainage layer. Calculate the total effective storage depth ( $d_t$ ), which is a function of the depth and porosity of the storage layers, using the following equation:

$$d_t = d_p + d_m n_m + d_d n_d$$

Where  $d_t$  = Total Effective Storage Depth (ft)

$d_p$  = Design Ponding Depth (ft)

$d_m$  = Planting Media Depth (ft)

$n_m$  = Planting Media Porosity

$d_d$  = Drainage Layer Depth (ft)

$n_d$  = Drainage Layer Porosity

#### Assumptions:

- Total effective storage depth ( $d_t$ ) is based on the storage capacity using the void space in the planting media and drainage layer and the ponding depth.
- Maximum ponding depth ( $d_p$ ), if check dams are used: 1 foot
- Average ponding depth: 0.5 feet (half of maximum ponding depth).
- Planting media depth ( $d_m$ ): 1.5 to 3 feet (typ.)
- Planting media porosity ( $n_m$ ): 0.2 to 0.35 (typ.) (NCHRP 2019)
- Drainage layer depth ( $d_d$ ): 8 to 12 inches (typ.)
- Drainage layer porosity ( $n_d$ ): 0.3 to 0.4 (typ.) (NCHRP 2019)

# Appendix A



## Enhanced Swale

T-3

### Design Criteria (continued)

4. Calculate the required swale bottom area ( $A_b$ ). Since the pretreatment forebay is sized for 10 percent of the WQV, the surface is calculated based on the remaining 90 percent of the WQV.

$$A_b = \frac{0.9WQV}{d_t}$$

Where  $A_b$  = Swale Bottom Area (ft<sup>2</sup>)

WQV = Water Quality Volume from Step 1 (ft<sup>3</sup>)

$d_t$  = Total Effective Water Storage Depth from Step 3 (ft)

5. Calculate the total area required ( $A_{BMP}$ ) to ensure adequate space is available.

$$A_{BMP} = \left[ b + 2z \left( f + \frac{d_p}{12} \right) \right] \times \frac{A_b}{b}$$

Where  $A_{BMP}$  = Total Surface Area (ft<sup>2</sup>)

$b$  = Bottom Width (ft)

$z$  = Swale Side Slope: length per unit height

$f$  = Freeboard (ft)

$d_p$  = Design Ponding Depth from Step 3 (inches)

$A_b$  = Swale Bottom Area from Step 4 (ft<sup>2</sup>)

### Assumptions:

- Minimum bottom width ( $b$ ): 2 feet to ensure adequate surface area for filtration and to facilitate mowing during maintenance.
- Maximum bottom width ( $b$ ): 10 feet to reduce land disturbance area.
- Swale side slope ( $z$ ): 3H:1V (typical) and 2H:1V (max.)
- Minimum freeboard ( $f$ ): 1 foot

6. Lastly, if the swale will convey the design peak flow (no high-flow bypass), check that the swale can adequately convey the design peak flow using Manning's equation while maintaining a minimum 1-foot freeboard. Adjust swale dimensions and recalculate, if necessary.

### ADDITIONAL DESIGN PARAMETERS

- Check dams (maximum 12-inch height) may be used to achieve velocity requirements, decrease runoff volume, rate, and velocity, and promote filtration and settling of nutrients and other pollutants.



## Enhanced Swale

T-3

### Design Criteria (continued)

- Underdrain System
  - Underdrain pipe (minimum 4-inch diameter) should be perforated PVC Schedule 40 pipe or equivalent corrugated HDPE pipe encased in a layer of #57 washed stone, 8- to 12-inches thick. Perforations should be 3/8-inch diameter at a minimum 6-inch on center spacing with a minimum of 4 holes per row (DOEE 2020).
  - Underdrain pipes shall be placed in the middle of the aggregate layer with perforations on the bottom side of the pipe.
  - Underdrain pipes shall be placed with a minimum slope of 0.5 percent.
  - Provide an observation well at every 250 to 300 feet along the underdrain system and a cleanout at the end of all underdrain pipe runs for cleaning and observation. Observation wells and cleanouts should be made of solid-wall PVC Schedule 40 pipe (minimum 4-inches in diameter).
  - Mark the depth of the trench on the observation well cap as reference for future maintenance.
- Provide a 2- to 4-inch filter layer of #7 washed stone between the planting media and the drainage layer.
- Place a non-woven filter fabric along the walls of the facility to reduce lateral flows.

### Pretreatment Considerations

- If receiving concentrated runoff directly from impervious surfaces, a pretreatment facility such as a sediment forebay or vegetated buffer strip is recommended to reduce incoming velocities and reduce the amount of sediment entering the treatment device.
- Provide a sediment forebay at the inlet sized to contain 0.1 inches per impervious acre of contributing drainage (10 percent of WQV). The storage in the forebay counts toward the total required WQV to be treated.
- A gravel trench or level spreader may be provided along the top edge of the enhanced swale to accommodate pretreatment for lateral sheet flows.

### Construction Considerations

- Avoid running equipment over the swale to prevent soil compaction.
- Install swales when there is a reasonable chance of successful establishment without irrigation when possible.
- Keep erosion and sediment controls in place until swale vegetation is established. Remove any accumulated sediment at the end of construction.
- If used to capture sediment during construction, overexcavate the bottom area a minimum of 6 inches and reconstruct as initially designed.

# Appendix A



## Enhanced Swale

T-3

### Landscaping Considerations

- Landscape design should specify proper plant species (preferably native) based on the specific site, soils and hydric conditions.
- Plants should be flood and drought-resistant.
- If grass is used, provide dense species to promote sedimentation, filtration, and nutrient uptake and to reduce flow velocities. Install erosion controls to protect seeds for at least 75 days after the first rainfall of the season.
- Avoid the use of fertilizer nutrients and amendments that have the potential to be washed into receiving waters.

### Maintenance and Inspections

- Research indicates that grass height and mowing frequency have little impact on pollutant removal. Thus, enhanced swales should be mowed only as required for safety and aesthetics or to suppress weeds and woody vegetation (CASQA 2003).
- Remove sediment as needed if restricting conveyance of the swale.
- Remove trash and debris as required to prevent clogging of downstream facilities.
- Inspect observation wells at least once a year to ensure the enhanced swale is operating properly.
- Clean underdrain pipes to remove sediment and debris.



## Enhanced Swale

T-3

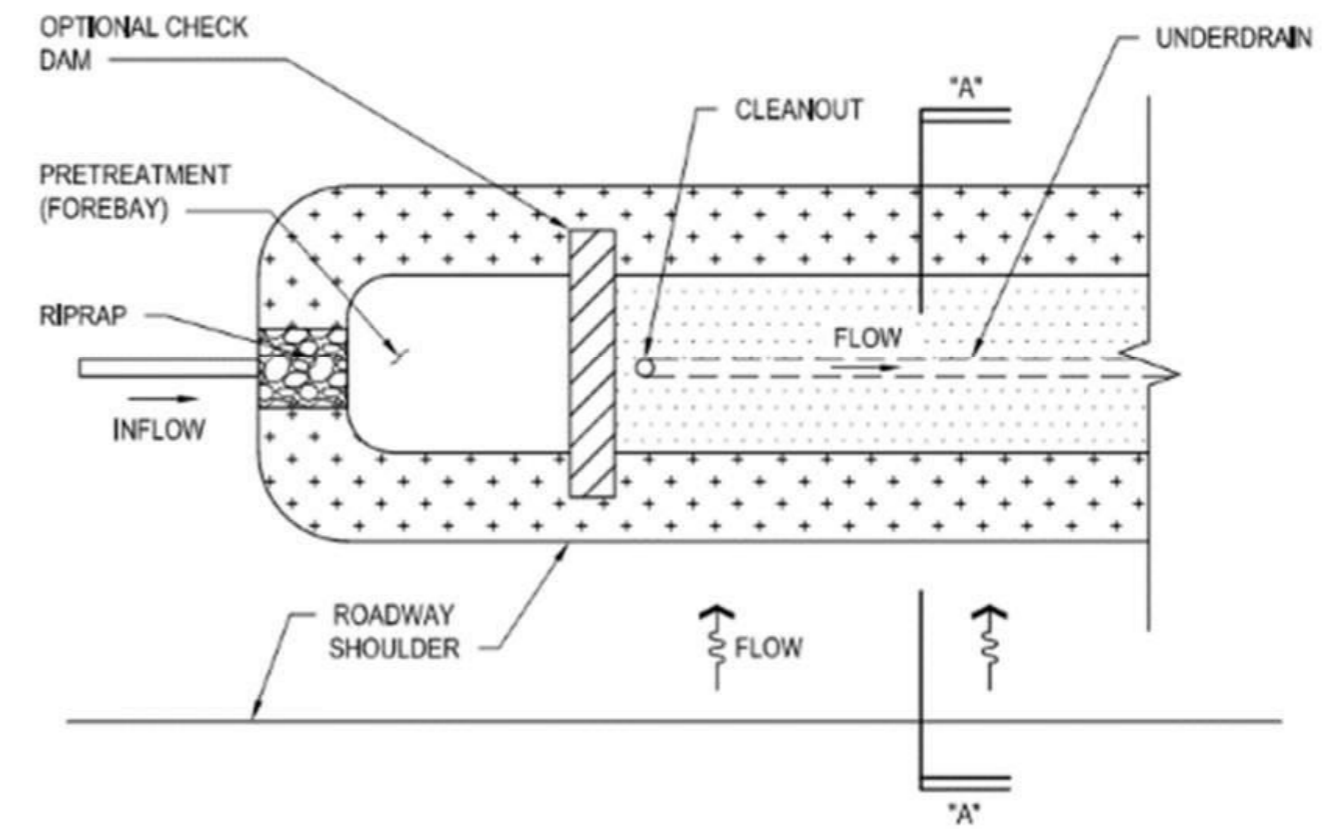

PLAN

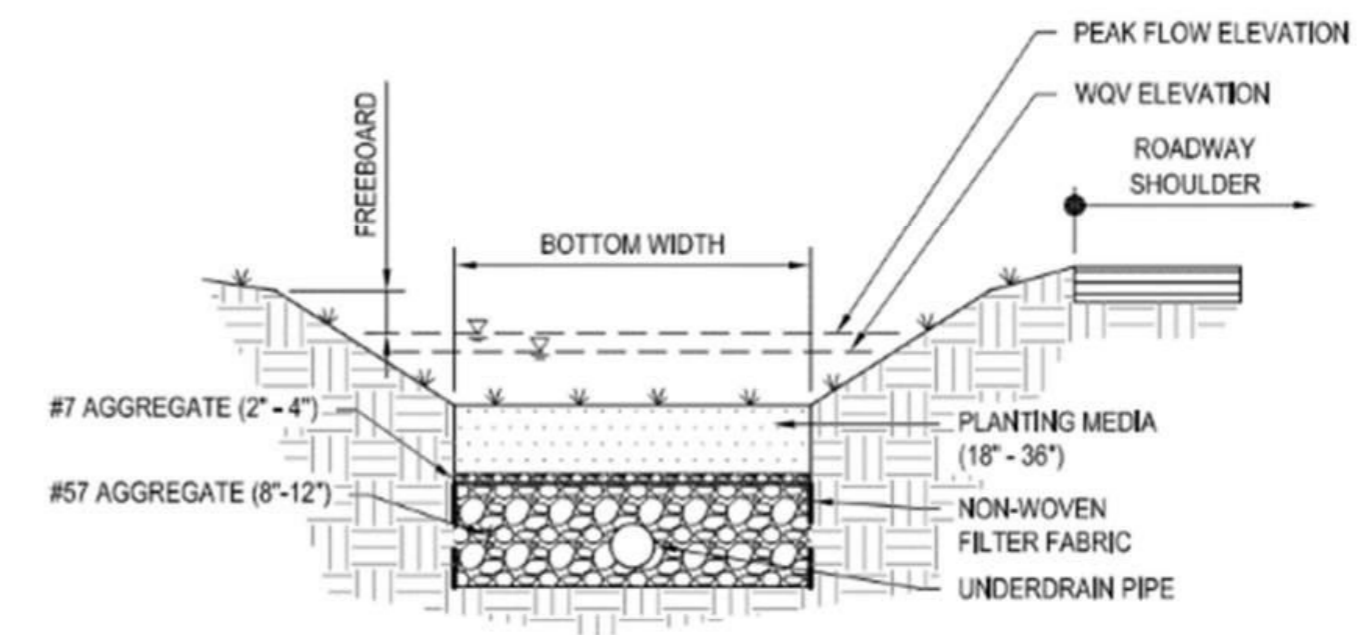

SECTION A-A

ENHANCED SWALE

# Criteria for **Public** Construction Projects in MS4 Permit Areas Oahu and Maui

All public construction projects that result in one (1) acre or more of Disturbed Area are required to implement LID BMPs.

**REVISED!**

Priority Projects that have a high potential for pollutant discharge may be required to implement post-construction BMPs at the discretion of DOT-HWYS regardless of the amount of Disturbed Area.

**DISTURBANCE** – Any construction-related activity that results in the penetration, turning, or moving of soil including roadway construction, demolition, grading, grubbing, and reconstruction of pavement which exposes the underlying base course or bare soil. Disturbance does not include clearing that leaves soil intact nor does it include the operation of vehicles, staging, and storage of materials and equipment on paved surfaces.

# Criteria for **Private** Construction Projects in MS4 Permit Areas Oahu and Maui

Post-construction BMPs may be required at the discretion of DOT-HWYS regardless of project size for private construction projects located within the DOT-HWYS right-of-way if the project has the potential to discharge storm water runoff to the DOT-HWYS right-of-way.

Private construction projects located outside the DOT-HWYS right-of-way are considered to be in compliance with post-construction BMP requirements if the project complies with the storm water quality requirements of the applicable county.

Projects which are located within or drain to sensitive receiving waters may be required to implement LID and/or non-LID BMPs at the discretion of DOT-HWYS regardless of the amount of Disturbed Area.

# Criteria for **Public** Construction Projects in NON-MS4 Permit Areas

All public construction projects that result in one (1) acre or more of new impervious surface are required to implement LID BMPs and/or non-LID BMPs.

Priority Projects that have a high potential for pollutant discharge may be required to implement post-construction BMPs at the discretion of DOT-HWYS regardless of the amount of new impervious surface created.

**IMPERVIOUS SURFACE** – Surface area which allows little or no infiltration such as asphalt and concrete pavements, bridge decks, sidewalks, walkways, concrete slabs, and roofs.

# Criteria for **Private** Construction Projects in NON-MS4 Permit Areas

Post-construction BMPs are only required for private construction projects if one (1) acre or more of new impervious surface is created within the DOT-HWYS right-of-way.

Post-construction BMPs are highly encouraged for private construction projects located outside of DOT-HWYS right-of-way.

Public construction projects that are located within or drain to sensitive receiving waters may be required to implement LID and/or non-LID BMPs at the discretion of DOT-HWYS regardless of the amount of new impervious surface created.

# Criteria for **Public** Construction Projects in NON-MS4 Permit Areas

Public construction projects that are located within or drain to sensitive receiving waters may be required to implement LID and/or non-LID BMPs at the discretion of DOT-HWYS regardless of the amount of new impervious surface created.

# MS4 Permit Areas

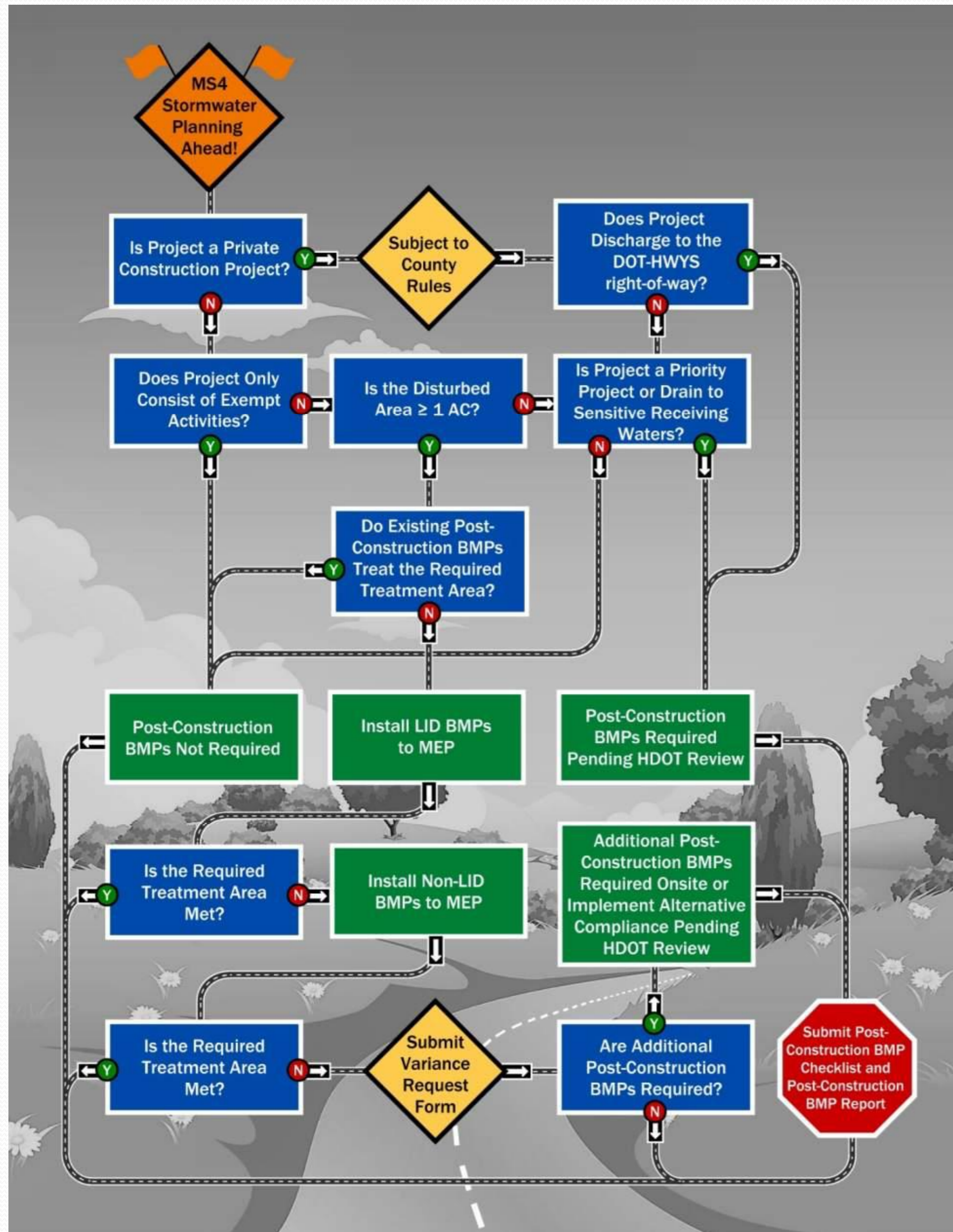

# Non-MS4 Permit Areas

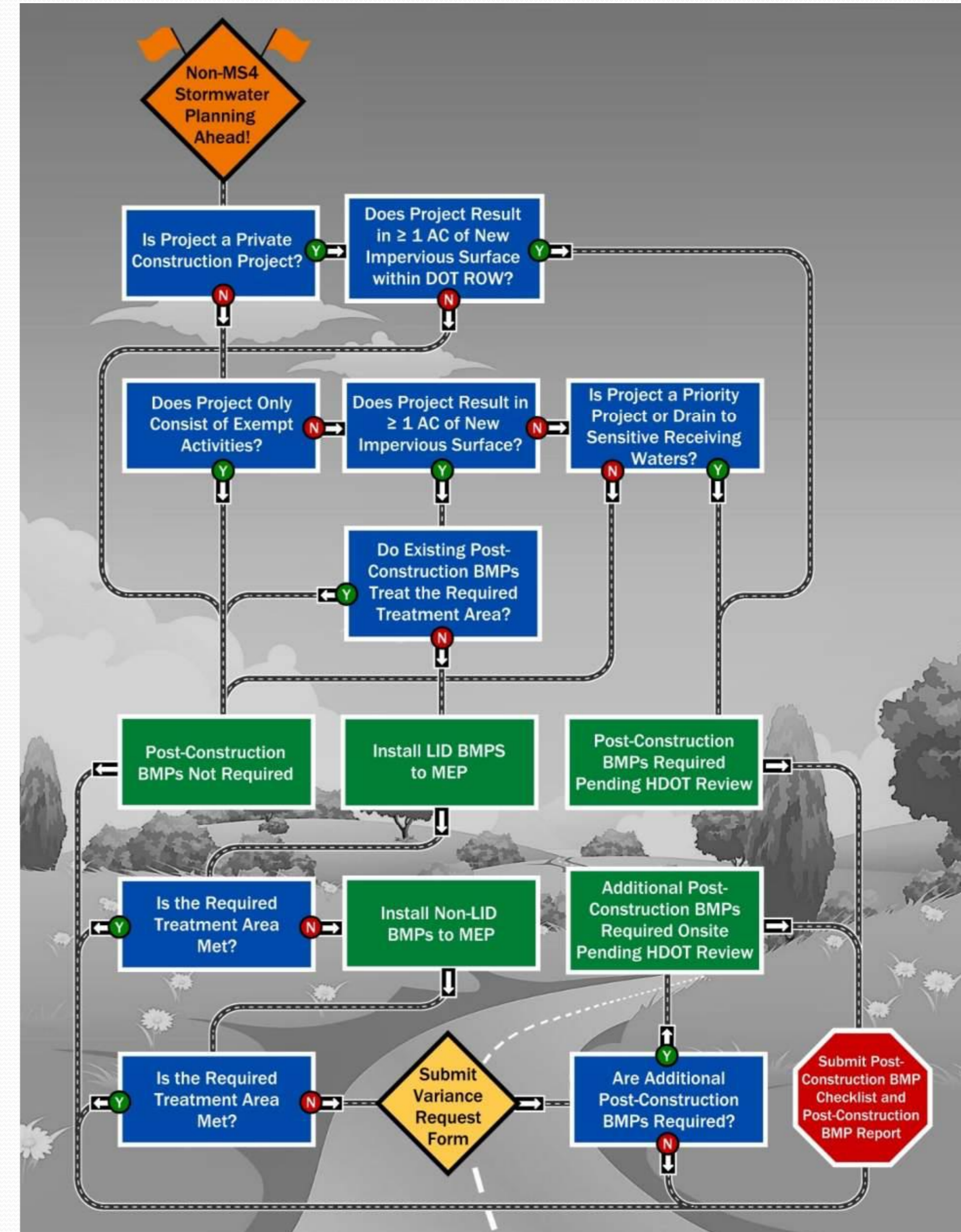

# Exemptions and Variances from Post-Construction BMPs

- . Projects that do not result in storm water discharge into the MS4 or state waters
- . Operations and Maintenance Activities
  - Structural Repairs
  - Baseyard Maintenance and Repairs
  - Installation or Replacement of Pavement Striping and Pavement Markers
- . Pavement Preservation Treatments
  - Pavement Resurfacing, Restoration, or Rehabilitation projects in which improvements are confined to the impervious pavement layer such as Pavement Overlays, Cold Planing, Crack Sealing, or Similar Treatments
- . Guardrail and Underground Utility Projects
  - Guardrail Installation or Replacement
  - Utility Installation or Relocation

# Exemptions and Variances from Post-Construction BMPs

- . Water Quality Improvements or Preservation
  - Shoreline Protection
  - Landscaping
  - Culvert Rehabilitation or Replacement
  - Installation of Post-Construction BMPs
  - Erosion and Sediment Control
  - Rockfall Mitigation
- . “Minor” Disturbance Project
  - Signage
  - ADA Ramps
  - Bridges or Roads constructed above or below existing impervious areas
- . Pedestrian Walkways or Bicycle Paths
- . Emergency Project
- . Temporary Project
- . Projects that are currently in the design phase in which timing and scheduling of the project for advertising may make it infeasible to comply with this revised manual.
- . Federal-aid city or county projects

# ALTERNATIVE COMPLIANCE

CURRENTLY FOR OAHU ONLY



<b>what</b>	Strategy that allows post-construction BMPs to be implemented in an alternative watershed
<b>when</b>	Allowed when a project cannot adequately treat the full Required Treatment Area
<b>how</b>	DOT-HWYS will identify an alternative watershed of similar or higher priority in which to provide additional water quality treatment
<b>why</b>	<ul style="list-style-type: none"><li>- Provides flexibility for MS4 Permit compliance</li><li>- Allows DOT-HWYS to target specific sensitive water bodies or pollutants</li><li>- Smaller post-construction BMPs from multiple projects may be combined into a larger single treatment device</li><li>- Improve economies of scale in administrative, construction, and maintenance costs</li></ul>

# ALTERNATIVE COMPLIANCE

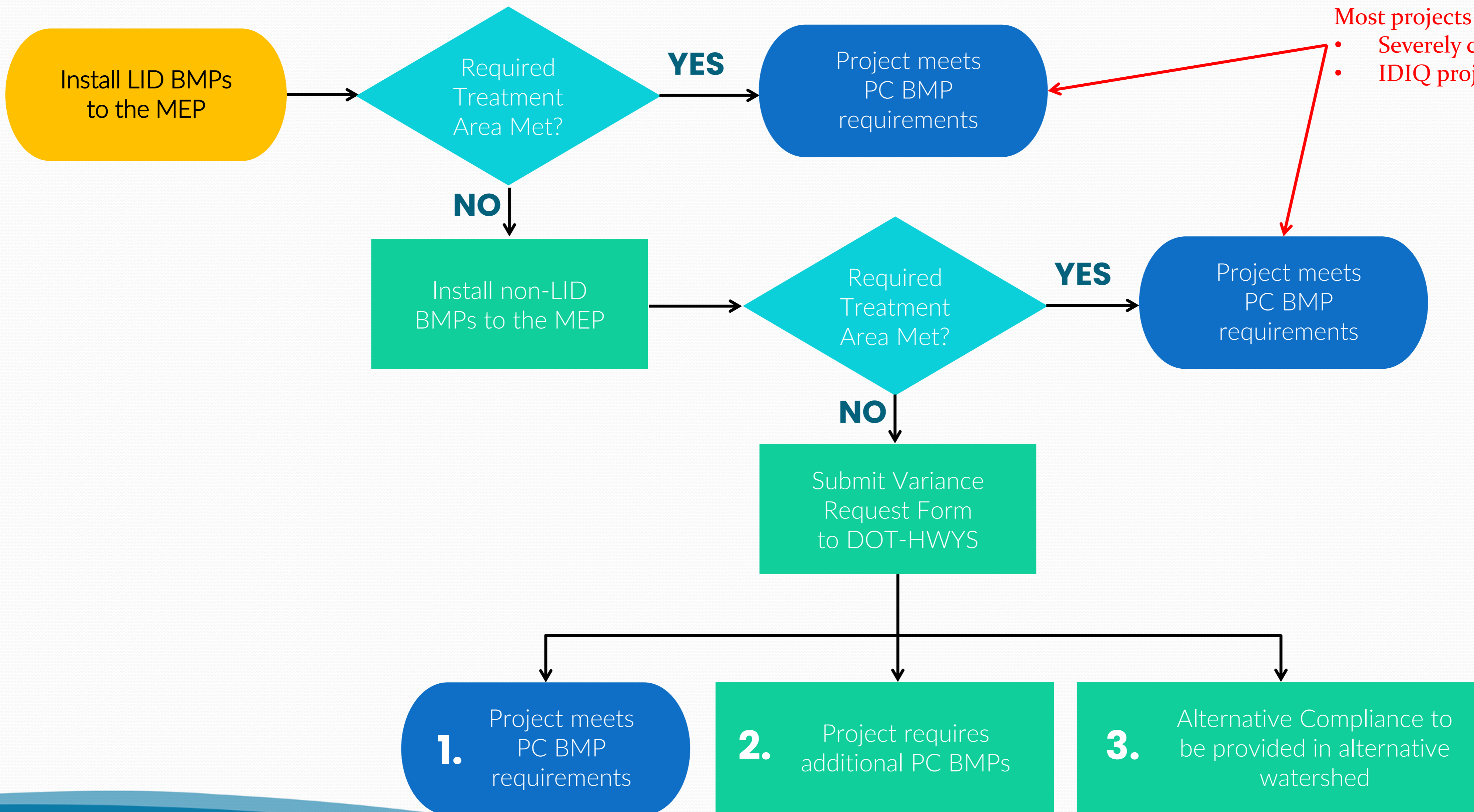

Most projects should end up here, except:

- Severely constrained projects
- IDIQ projects

# CREDIT TRACKING PROGRAM

**NEW!**

- Measured in units of “treatment area”
- Projects that treat **more** than what is required will generate a **CREDIT**
- Projects that treat **less** than what is required will generate a **DEBIT**
- If a project creates more debits than credits, submit a Variance Request Form to justify that all other options were evaluated and deemed infeasible.
- Documentation will be used to verify program compliance

## CREDITS

- Post-construction BMPs are sized to treat an impervious area larger than the Required Treatment Area
- Project results in a reduction of impervious surface area
- Retrofit existing highway facilities
- Create a stand-alone post-construction BMP project to target specific watershed or pollutant

## DEBITS

- Project results in an increase of impervious surface area
- Existing post-construction BMPs are removed or no longer provide treatment



# ALTERNATIVE COMPLIANCE

**NEW!**

- Allowed for public construction projects only
- Alternative watershed of equal or higher priority to be identified by DOT-HWYS
- TMDL or 303(d)-listed watersheds
- Relies on tracking system for credits and debits per watershed

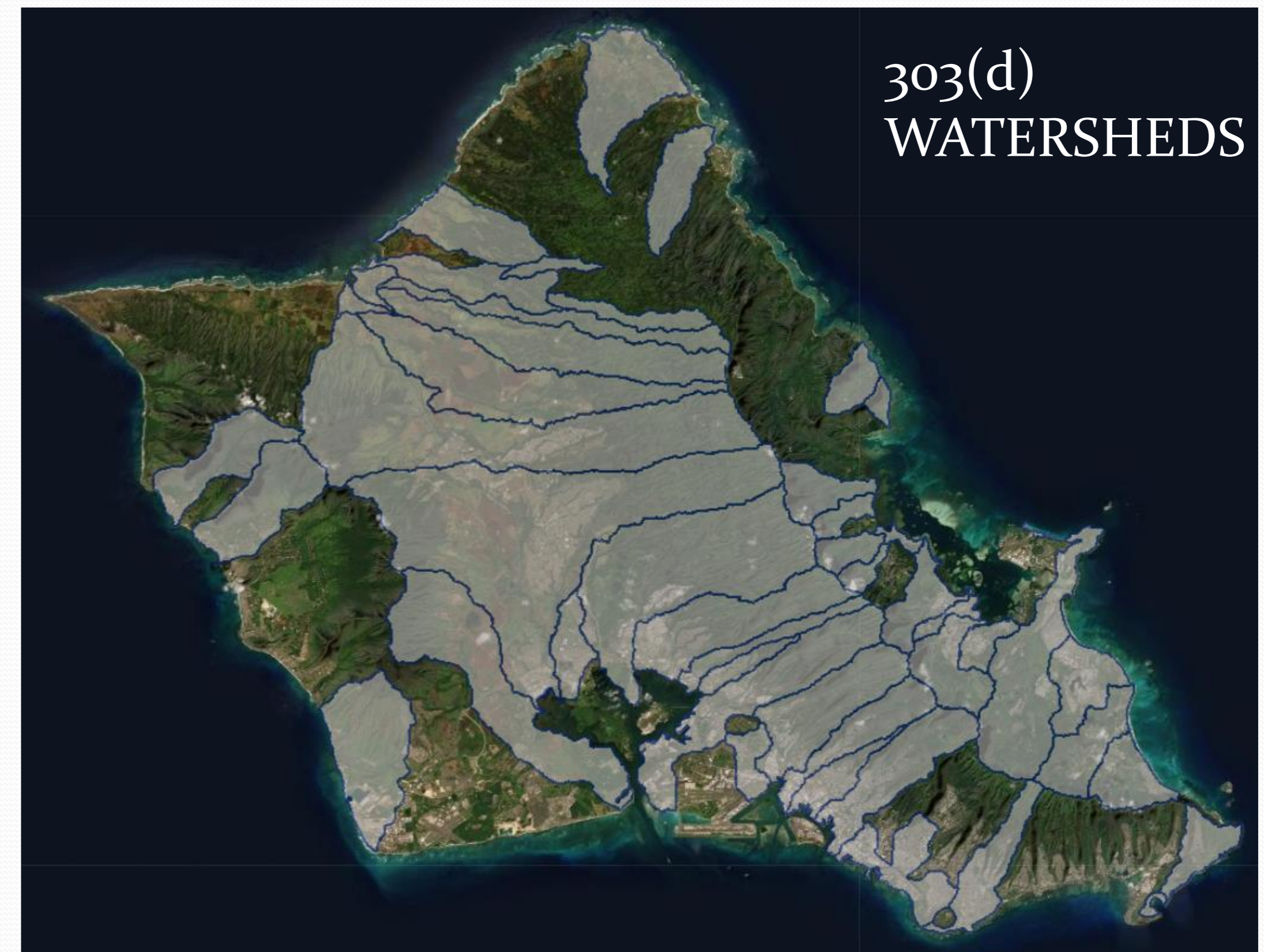
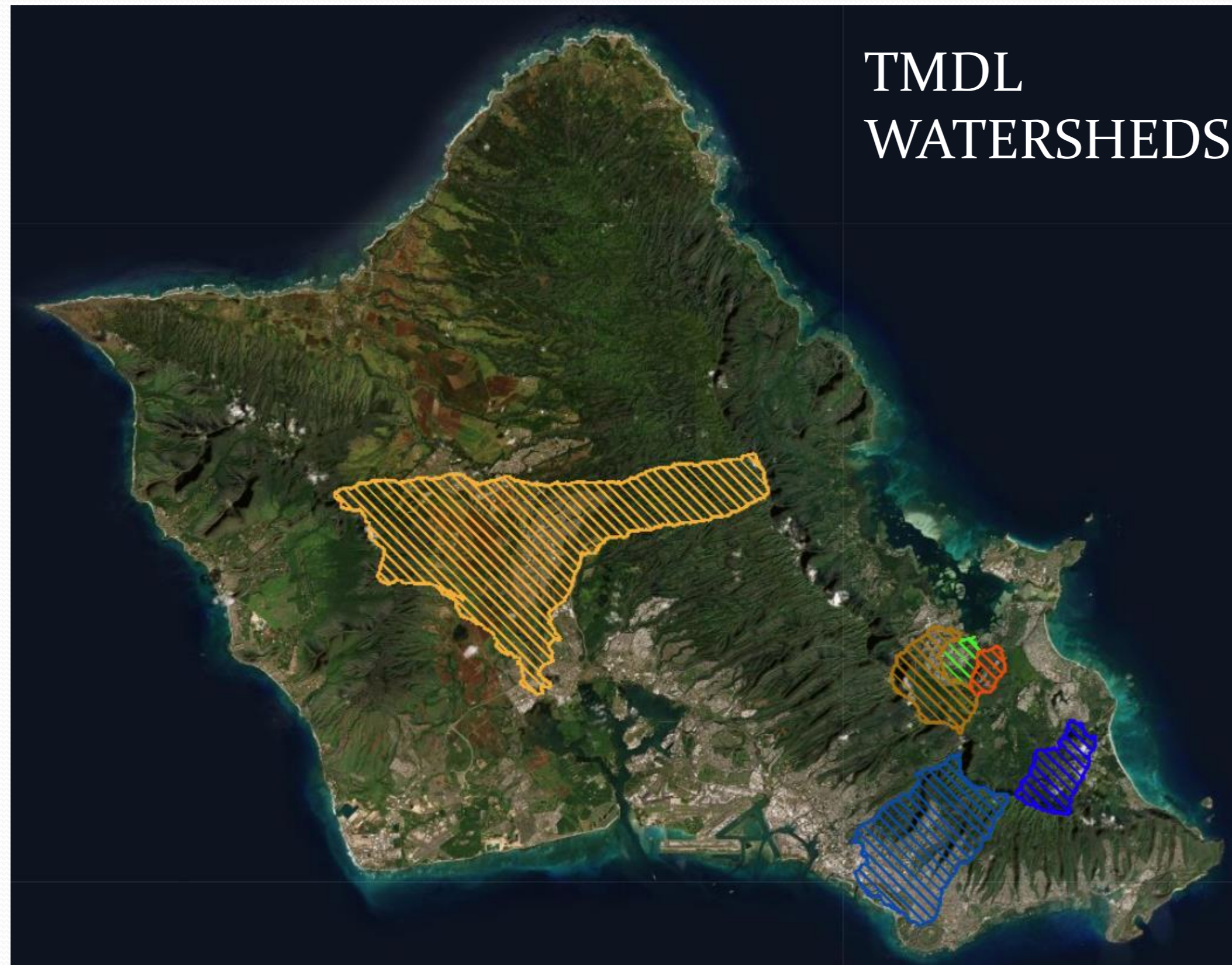

# WATER QUALITY SUMMARY SHEET



## Water Quality Summary Sheet

Project :	BMP Test Site											<b>FOR MS4 TRACKING PURPOSES:</b>				
Proj. No.:	10001											Required Treatment Area due to New Development (acres) =		1.00		
Island:	Oahu											Required Treatment Area due to Redevelopment (acres) =		0.25		
PC BMP Checklist Filing Date:												Net Credit/Debit to WQBank (acres) =		-0.25		
Project Watershed	Project Watershed Priority	NEW DEVELOPMENT			REDEVELOPMENT		EXISTING TREATMENT		TOTAL REQUIRED TREATMENT AREA (acres)	Primary BMP Type Used for Treatment	Impervious Area Treated (acres)	CREDIT OR DEFICIT (acres)	ALTERNATIVE COMPLIANCE			
		Existing Impervious Removed (acres)	New Impervious Added (acres)	Required Treatment Area from New Development (acres)	Redevelopment (acres)	Required Treatment Area from Redevelopment (acres)	Existing Treatment of Redev Area to Remain (acres)	Existing Treatment of Redev Area Lost (acres)					MEP APPLIED? (Y or N)	Alternative Compliance Watershed (if needed) <sup>1</sup>	Alternative Compliance Watershed Priority <sup>2</sup>	Priority Error
	"Watershed" Tab			ND		RD			A <sub>T</sub>			(M-K)			"Watershed" Tab	
Aiea	1	0.00	1.00	1.00	1.00	0.25	0.00	0.00	1.25	Bioretention Basin	1.00	-0.25	Y	Kaelepulu	1	GOOD
<b>TOTAL</b>				<b>1.00</b>		<b>0.25</b>						<b>-0.25</b>				

<sup>1</sup> Enter Alternative Compliance Watershed only if needed to address treatment deficit

<sup>2</sup> Alternative Compliance Watershed must be of equal or higher priority than the Project Watershed ("1" = Highest Priority, "4" = Lowest Priority)

# ALTERNATIVE COMPLIANCE



## 2022 STATE OF HAWAII WATER QUALITY MONITORING AND ASSESSMENT REPORT:

Integrated Report to the U.S. Environmental Protection Agency and the U.S. Congress  
Pursuant to §303(d) and §305(b), Clean Water Act (P.L. 97-117)



303(d)  
WATERSHEDS

The Hawaii State Department of Health  
Clean Water Branch  
Honolulu, Hawaii  
February 14, 2022

# INSPECTIONS, OPERATION, AND MAINTENANCE

## Inspections During Construction:

- During excavation to subgrade or sub-foundation especially for infiltration facilities to ensure subgrade remains uncompacted.
- During placement of underdrain systems and observation wells.
- During backfill for foundations, trenches, underdrain systems and observation wells.
- During placement of geotextile and filter media.
- During the placement of structural fill beneath drainage structures.
- During construction and installation of components of the treatment process such as diversion structures, pretreatment forebays, inlets, outlets, media filters, overflow pipes, outfalls, and flow distribution structures.
- Upon establishment of permanent stabilization.
- During vegetative planting and plant maintenance periods.
- At any critical construction stage highlighted by the manufacturer for proprietary treatment control BMPs.

# INSPECTIONS, OPERATION, AND MAINTENANCE

## Inspections During Construction



Enhanced/Bioswale Construction

(d)  
WATERSHEDS

# INSPECTIONS, OPERATION, AND MAINTENANCE

## Inspections During Construction



DSBB Construction

# INSPECTIONS, OPERATION, AND MAINTENANCE

Long-term Inspection, Operation, and Maintenance requirements are to be included in the Storm Water Post-Construction BMP Design Report and should include:

- Inspection Frequency
- Maintenance Threshold or Frequency
- Maintenance Equipment Requirements
- Estimated Maintenance Costs

CDS® Inspection and Maintenance Guide



# INSPECTIONS, OPERATION, AND MAINTENANCE

## Maintenance Considerations During Design



303(d)  
WATERSHEDS

Inspection and Maintenance Access

# INSPECTIONS, OPERATION, AND MAINTENANCE

## Maintenance Considerations During Design



Inspection and Maintenance Access



# QUESTIONS?

Please submit questions to Ben Phillips by Friday May 20<sup>th</sup>.

[bphillips@gotoetc.com](mailto:bphillips@gotoetc.com)

303(d)  
WATERSHEDS

7

**POST-CONSTRUCTION BMP  
DESIGN METHODOLOGY**

8

**POST-CONSTRUCTION BMP  
DEVELOPMENT IN PLANNING PHASE**

9

**POST-CONSTRUCTION BMP DEVELOPMENT  
IN DESIGN PHASE**

10

**INSPECTIONS, OPERATION, AND  
MAINTENANCE**

A

**APPENDIX A – TREATMENT CONTROL BMPs**



# POST-CONSTRUCTION BMP DESIGN METHODOLOGY

For PUBLIC construction projects...

	Current Criteria (2015 Manual)	New Criteria (2022 Manual)
Within MS4 Permit Areas (Oahu, Maui)	All public construction projects that result in one (1) acre or more of <b>new impervious area</b> are required to implement LID BMPs	All public construction projects that result in one (1) acre or more of <b>disturbed area</b> are required to implement LID BMPs
Within Non-MS4 Permit Areas (Hawaii, Kauai, Molokai, Lanai)		All public construction projects that result in one (1) acre or more of <b>new impervious area</b> are required to implement LID BMPs

# POST-CONSTRUCTION BMP DESIGN METHODOLOGY

## REVIEW OF KEY DEFINITIONS

**Disturbance** – Any construction-related activity that results in the penetration, turning, or moving of soil including roadway construction, demolition, grading, grubbing, and reconstruction of pavement which exposes the underlying base course or bare soil.

Excludes clearing that leaves soil intact and does not include the operation of vehicles, staging, and storage of materials and equipment on paved surfaces.

PENETRATE  
INTO SOIL

EXPOSE  
AGGREGATE

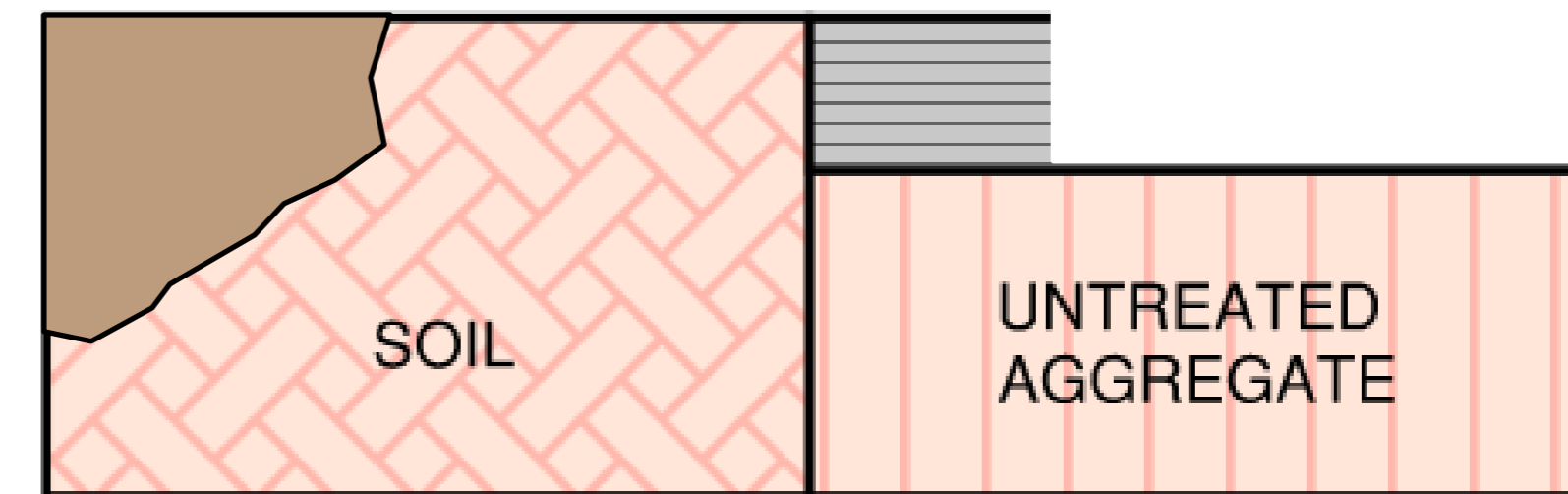

DISTURBANCE

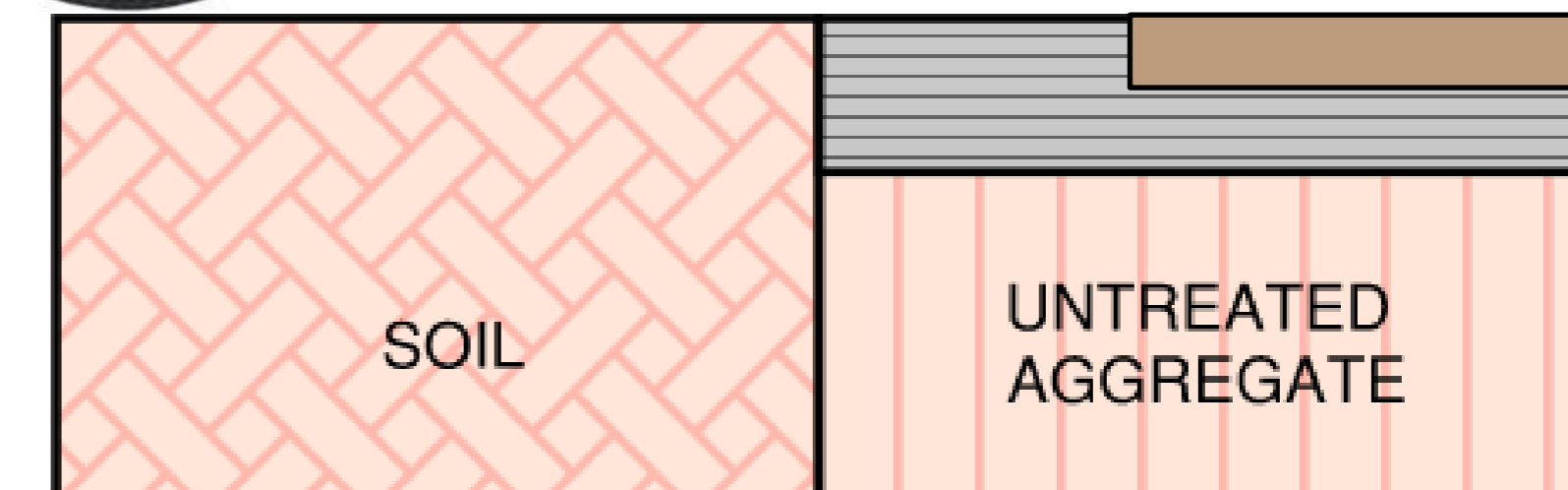

NOT DISTURBANCE

# POST-CONSTRUCTION BMP DESIGN METHODOLOGY

## REVIEW OF KEY DEFINITIONS

**New Development (ND)** - construction of any **new impervious surface intended for vehicular use.**

- Roadway corridors
- Roadway intersections
- Roadway access ramps
- Roadway realignment
- Roadway widening
- Baseyard facilities
- Parking lots



# POST-CONSTRUCTION BMP DESIGN METHODOLOGY

## REVIEW OF KEY DEFINITIONS

**Redevelopment (RD)** - construction, reconstruction, alteration, or improvement on **existing impervious surfaces in which the underlying untreated aggregate or pervious subgrade is exposed or penetrated.**

Excludes pavement preservation treatments:

- Pavement overlays
- Crack sealing
- Pavement resurfacing
- Cold planing (mill and fill)
- Slurry seals

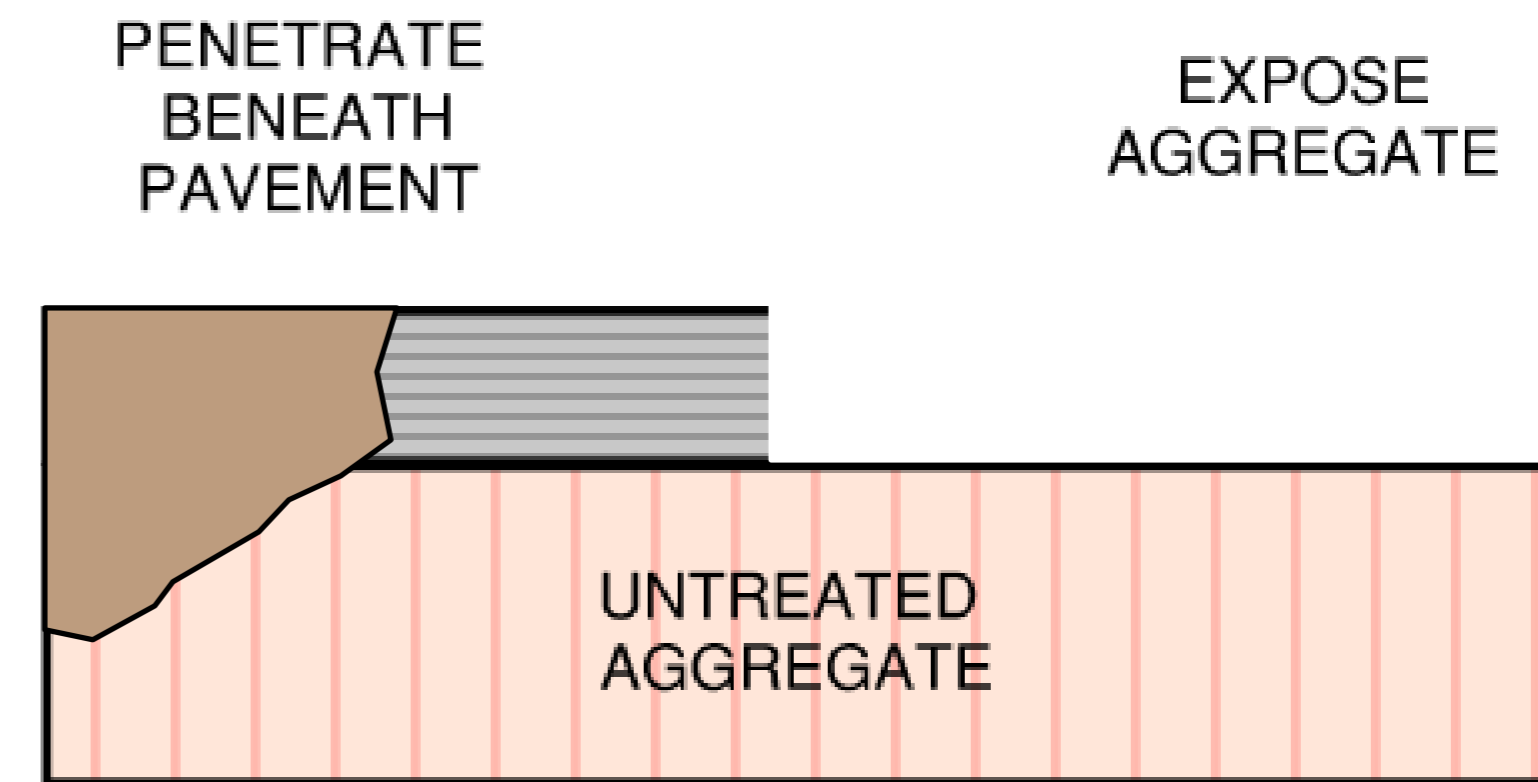

REDEVELOPMENT

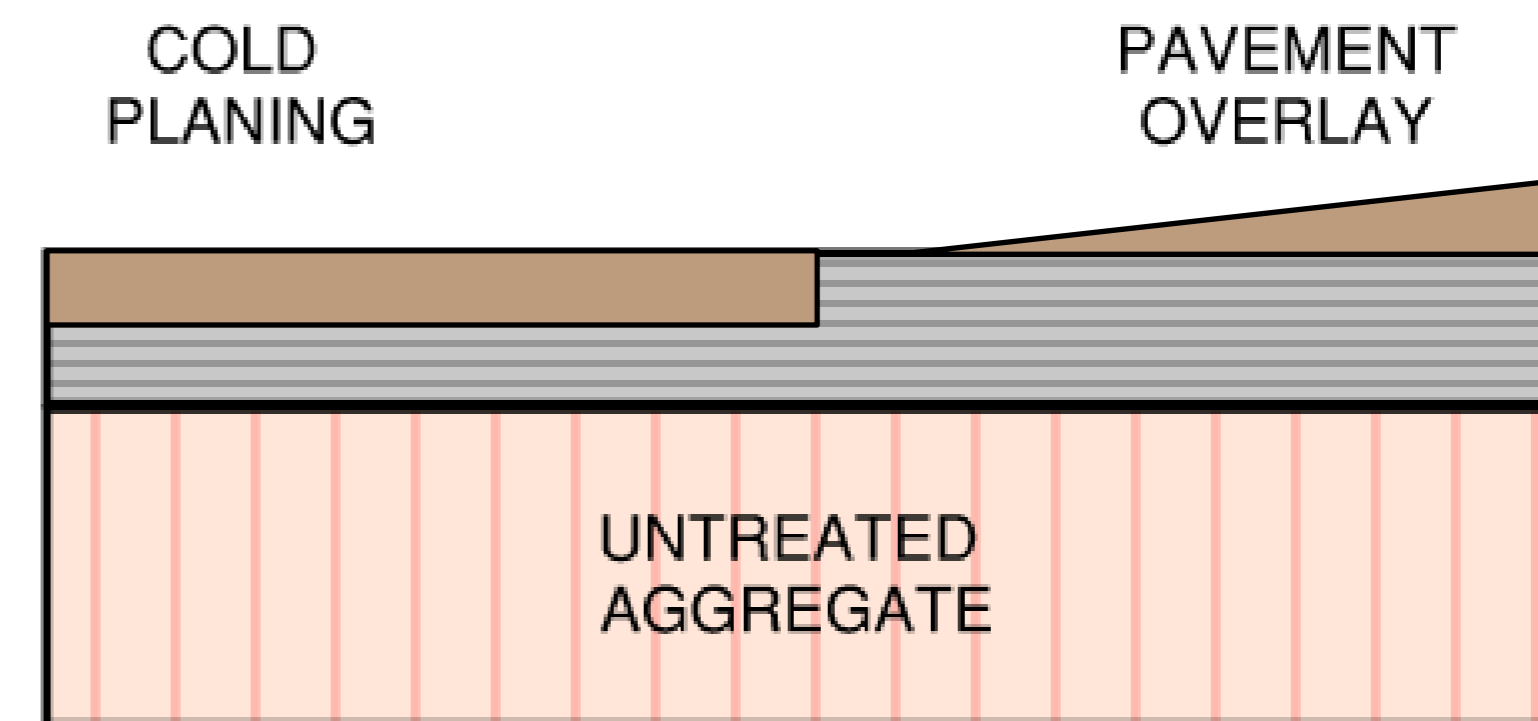

NOT REDEVELOPMENT

# POST-CONSTRUCTION BMP DESIGN METHODOLOGY

## ARE POST-CONSTRUCTION BMPs REQUIRED?

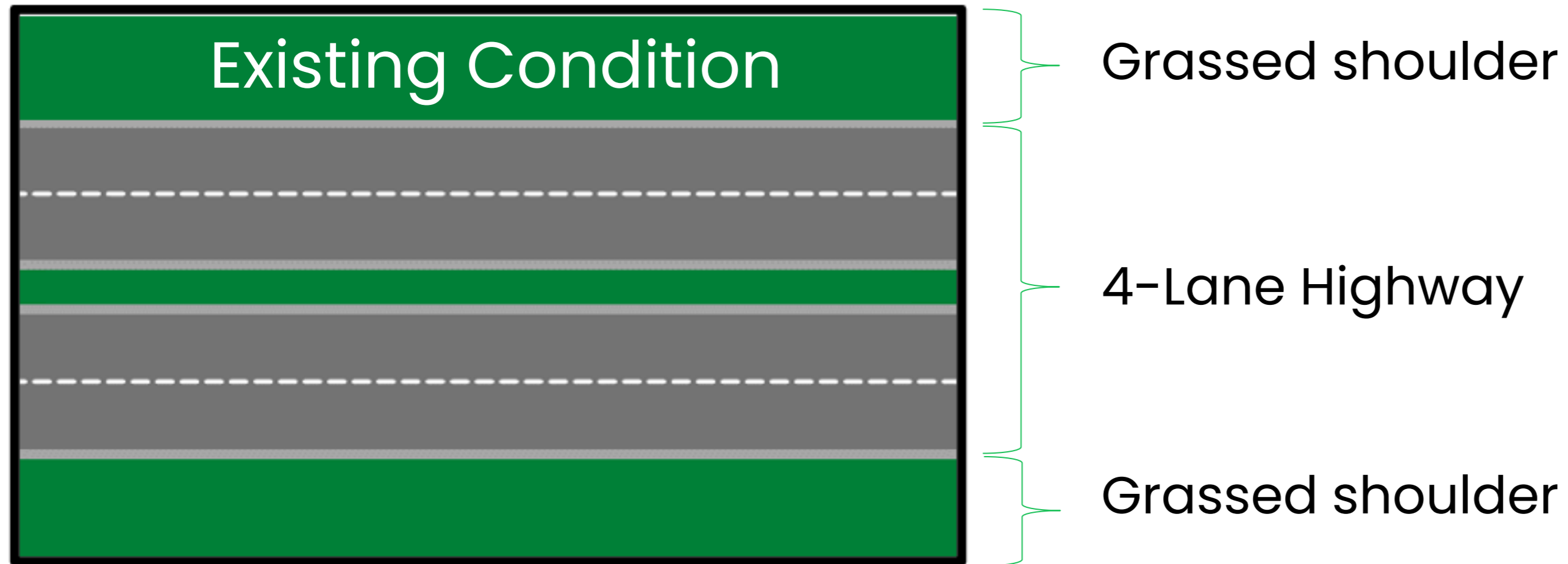

All public construction projects that result in one (1) acre or more of **Disturbed Area** are required to implement LID BMPs

Project location = Oahu (MS4 Permit Area)

1 new lane constructed	= 0.75 AC
1 existing lane reconstructed	= 1 AC
Disturbed pervious area	= 1 AC
<hr/> Total Disturbed Area	<hr/> = 2.75 AC

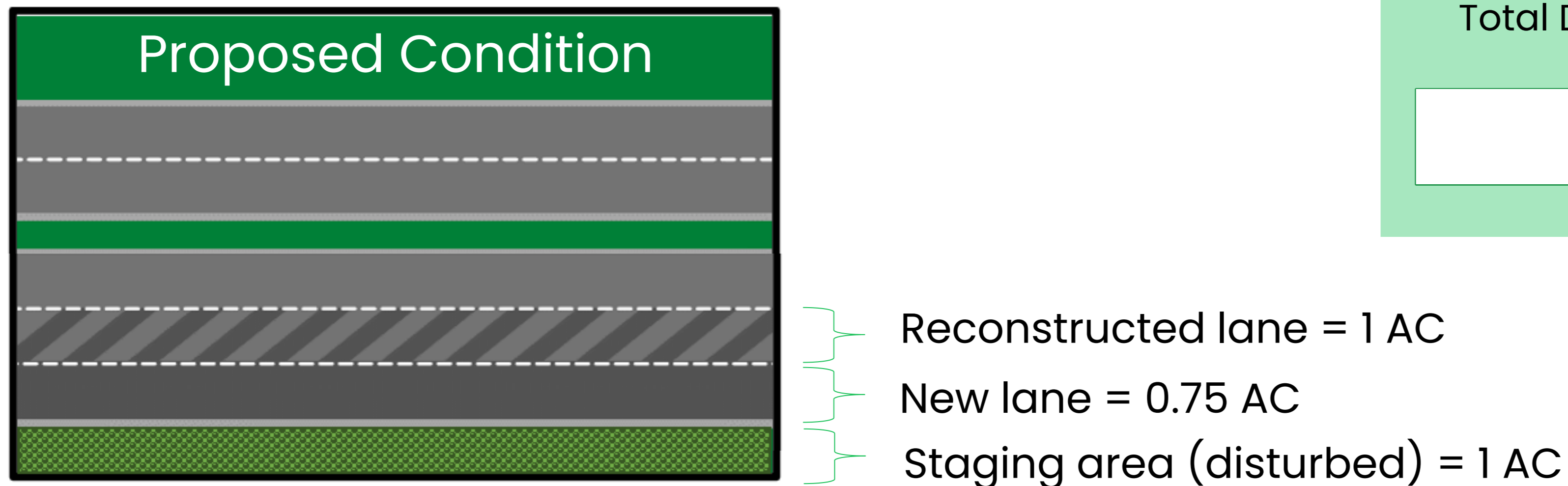

**LID BMPs ARE REQUIRED**

# POST-CONSTRUCTION BMP DESIGN METHODOLOGY

## HOW MUCH TREATMENT IS REQUIRED?

### Required Treatment Area ( $A_T$ )

$$A_T = ND + (RD \times F) - A_{TE}$$

Where  $A_T$  = Required Treatment Area (acres)

ND = New Development resulting in new impervious surface (acres)

RD = Redevelopment of existing impervious surface (acres)

F = Redevelopment Treatment Fraction

= 0.25 for MS4 Permit areas

= 0 for non-MS4 Permit areas

$A_{TE}$  = Area Treated by Existing BMPs (acres)

# POST-CONSTRUCTION BMP DESIGN METHODOLOGY

## HOW MUCH TREATMENT IS REQUIRED?

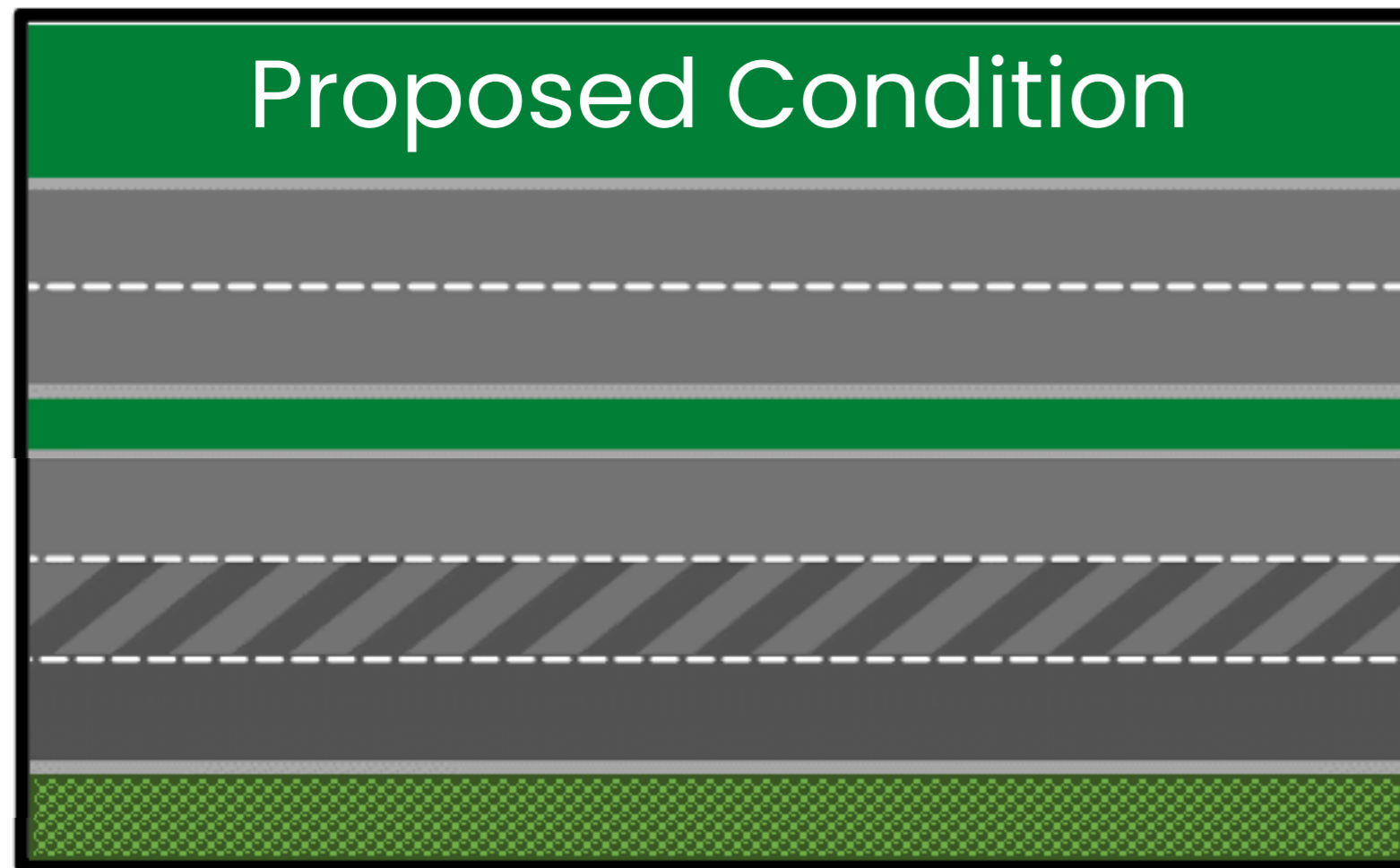

Reconstructed lane = 1 AC  
New lane = 0.75 AC

### Required Treatment Area ( $A_T$ )

$$\begin{aligned} A_T &= ND + (RD \times F) - A_{TE} \\ &= 0.75 + (1 \times 0.25) - 0 \\ &= \underline{1.0 \text{ acres}} \end{aligned}$$

$A_T$  = Required Treatment Area (AC)  
ND = New Development (AC)  
RD = Redevelopment (AC)  
F = Redevelopment Treatment Fraction  
= 0.25 for MS4 Permit Areas  
 $A_{TE}$  = Area Treated by Existing BMPs (AC)

# POST-CONSTRUCTION BMP DEVELOPMENT IN PLANNING PHASE

## Highlighted Changes

- Separate post-construction BMP planning concept report no longer required
- If a planning report, EA, or EIS is required for the project, include preliminary post-construction BMP information
- Otherwise, include BMP information in Post-Construction BMP Design Report during design phase

## Post-Construction BMP information to include:

- BMP description
- TMDL or WLA requirements
- Right-of-way requirements
- Maintenance requirements
- Construction cost estimate

## Figures

- Drainage maps
- Post-construction BMP locations
- Flood Zone designations and boundaries

## Supporting Documentation

- Hydrologic and hydraulic calculations
- BMP sizing calculations
- Product data information
- Site photos

# POST-CONSTRUCTION BMP DEVELOPMENT IN DESIGN PHASE

## Highlighted Changes

- Infiltration test requirements
  - Infiltration Basins and Bioretention Facilities: A minimum of one (1) test for every 2,500 square feet of treatment area.
  - Infiltration Trenches and Enhanced Swales: A minimum of one (1) test for every 100 linear feet of trench.
  - Safety Factor: Min. safety factor = 2
- Technological verification requirements for proprietary treatment devices
  - Name/Brand of proprietary device
  - Manufacturer's product literature
  - Expected pollutant removal effectiveness
  - Technological verification (NJCAT, TAPE)
  - Warranty information
  - Operations and maintenance (O&M) requirements

# POST-CONSTRUCTION BMP DEVELOPMENT IN DESIGN PHASE

## Highlighted Changes

- Updated Post-Construction BMP Design Checklist
- Separate checklist for MS4 and non-MS4 Permit Areas
- New Variance Request Form

Yes



# POST-CONSTRUCTION BMP DESIGN CHECKLIST

2. Is project a private construction project?  
 Yes

New Submittal  
 Resubmittal

## STORM WATER POST-CONSTRUCTION BMP DESIGN CHECKLIST FOR MS4 PERMIT AREAS

### Project Information

Project Name: \_\_\_\_\_ Island: \_\_\_\_\_  
 Project Number: \_\_\_\_\_ Milepost Begin/End: \_\_\_\_\_  
 Project Route Name(s): \_\_\_\_\_  
 Watershed Location(s): \_\_\_\_\_ New Impervious Area (acres): \_\_\_\_\_  
 Disturbance Area (acres): \_\_\_\_\_  
 Applicant Name: \_\_\_\_\_ Company: \_\_\_\_\_  
 Email: \_\_\_\_\_ Telephone: \_\_\_\_\_

### Applicability

1. Check "Yes" if project entirely consists of one or more of the following activities or conditions below. The project may be exempt from Post-Construction BMPs if it includes these exempted activities **ONLY**. Otherwise, if the project includes other types of improvements not listed below, continue to Step 2.

Activity	Yes
a. Project does not result in storm water discharge into the MS4 or state waters	<input type="checkbox"/>
b. Operations and Maintenance activities	<input type="checkbox"/>
b.1 Structural repairs	<input type="checkbox"/>
b.2 Baseyard maintenance and repairs	<input type="checkbox"/>
b.3 Installation or replacement of pavement striping and pavement markers	<input type="checkbox"/>
b.4 Other _____	<input type="checkbox"/>
c. Pavement Preservation Treatment which does not expose or disturb underlying aggregate or subgrade layer	<input type="checkbox"/>
d. Guardrail and Underground Utility Projects	<input type="checkbox"/>
d.1 Guardrail installation or replacement	<input type="checkbox"/>
d.2 Utility installation or relocation	<input type="checkbox"/>

- Checklist should be submitted at first design submittal
- Resubmit checklist for subsequent submittals if substantial changes are made
  - Disturbed area
  - Impervious area
  - Drainage pattern
  - Runoff quantity
  - Type or size of proposed post-construction BMP

# APPENDIX A – TREATMENT CONTROL BMPs

## Highlighted Changes

- Updated toolbox of treatment control BMPs
- Simplified BMP summary tables
- Revised BMP fact sheets



## Bioretention Facility

T-6



SOURCE: New Jersey Developers Green Infrastructure Guide 2018

Typical Targeted Pollutants for Removal	
Sediment	x
Nutrients	x
Oil & Grease	x
Metals	x
Trash	x
Bacteria	x

Other Considerations <sup>1</sup>	
Construction Cost	Moderate
Maintenance Cost	Moderate
Effective Life	5-20 years

<sup>1</sup> Source: Washington State DOT, Highway Runoff Manual 2019

### Description & Purpose

Bioretention facilities are vegetated depressions where storm water runoff is directed through vegetation and designed soil mixes for infiltration and treatment. Soil mix may include a combination of sand, organic matter, soil, or other media. Excess flows may be bypassed to drainage structures further downstream. Design variations include bioretention cells, bioretention swales, and bioretention planters. Smaller facilities are also commonly referred to as rain gardens.

### Applications

A bioretention facility is a versatile post-construction BMP that provides water quality treatment, storm water volume reduction, and flow attenuation. Appropriate in locations where adequate space is available. The overall shape can be adjusted to fit within the allotted space so is well suited in a variety of urban settings including roadway applications, parking lots, and curb extensions for smaller devices.

### Limitations

- Requires pretreatment upstream to capture sediment loadings which would otherwise lead to clogging and premature failure.

# TREATMENT CONTROL BMP SUMMARY MATRIX

Treatment Control BMP		Typical Targeted Pollutants for Removal					Notes	
		Sediment <sup>1</sup>	Nutrients <sup>1</sup>	Oil & Grease <sup>2</sup>	Metals <sup>1</sup>	Trash <sup>2</sup>		Bacteria <sup>1</sup>
LID	Vegetated Buffer Strip	x		x		x		
	Vegetated Swale	x		x		x		
	Enhanced Swale	x	x	x	x	x		
	Infiltration Trench	x	x	x	x	x	x	
	Infiltration Basin	x	x	x	x	x	x	
	Bioretention Facility	x	x	x	x	x	x	
	Permeable Pavement	x	x	x	x		n/a	
	Pocket Wetland	x	varies	x	x	x	x	
	Rainwater Harvesting	varies	varies	n/a	varies	n/a	varies	Primarily for runoff reduction
	Tree Box Filter	x	x	x	n/a	x	x	
TRADITIONAL NON-LID	Wet Pond	x	x	x	x	x	x	
	Wet Extended Detention Pond	x	x	x	x	x	x	
	Sand Filter	x	varies	x	x	x		
PROPRIETARY NON-LID	Drain Inlet Filter	x				x		Results vary depending on type/model. Refer to manufacturer's data for targeted pollutant removal efficiencies.
	Modified Catch Basin	x				x		
	Oil/Grit Separator	x		x	n/a	x	n/a	
	Centrifugal Hydrodynamic Separator	x		x	x	x		
	Multi-Stage Hydrodynamic Separator	x		x	x	x		

- Simplified to show general performance for pollutant removal
  - Sediment
  - Nutrients
  - Oil and Grease
  - Metals
  - Trash
  - Bacteria
- Low Impact Development
- Traditional Non-LID
- Proprietary Non-LID

# TREATMENT CONTROL BMPs

## LOW IMPACT DEVELOPMENT (LID)

- Vegetated Buffer Strip
- Vegetated Swale
- Enhanced Swale
- Infiltration Trench
- Infiltration Basin
- Bioretention Facility
- Permeable Pavement
- Pocket Wetland
- Rainwater Harvesting
- Tree Box Filter

## TRADITIONAL NON-LID

- Wet Pond
- Wet Extended Detention Basin
- Sand Filter

## PROPRIETARY NON-LID

- Drain Inlet Filter
- Modified Catch Basin
- Oil and Grit Separator
- Centrifugal Hydrodynamic Separator
- Multi-Stage Hydrodynamic Separator

# TREATMENT CONTROL BMPs

## VOLUME-BASED BMPs



Incorporates storage to achieve water quality treatment through retention and infiltration of storm water runoff

Wet ponds

Wetlands

Infiltration facilities

Bioretention facilities

## FLOW-BASED BMPs



Treat storm water by capturing pollutants as they pass through filtration media, via infiltration, or sedimentation

Buffer strips

Vegetated swales

Media Filters

# VOLUME-BASED BMP DESIGN

## Water Quality Volume (WQV)

$$WQV = P \times C \times A_T \times 3630$$

Where WQV = Water Quality Volume (ft<sup>3</sup>)  
P = Design Storm Runoff Depth = 1 inch  
C = Volumetric Runoff Coefficient  
A<sub>T</sub> = Treatment Area (acres) ←  
3630 = conversion factor

**Impervious area only**



# FLOW-BASED BMP DESIGN

## Water Quality Flow Rate (WQFR)

$$WQFR = C \times i \times A_T$$

Where WQFR = Water Quality Flow Rate (cfs)

C = Runoff Coefficient

i = Rainfall Intensity = 0.4 in/hr

$A_T$  = Treatment Area (acres) ←

**Impervious area only**



# DESIGN EXAMPLES

1. Public Project within DOT ROW (MS4 Permit Area)
2. Public Project within DOT ROW with Alternative Compliance (MS4 Permit Area)
3. Private Project partially within DOT ROW

# DESIGN EXAMPLE #1

Public Project within DOT ROW (MS4 Permit Area)

- Computing disturbed areas
- Computing Required Treatment Area
- Selection and Design of post-construction BMP (Bioretention Facility)
- Completing the post-construction BMP Design Checklist

# DESIGN EXAMPLE #1

## Public Project within DOT ROW (MS4 Permit Area)

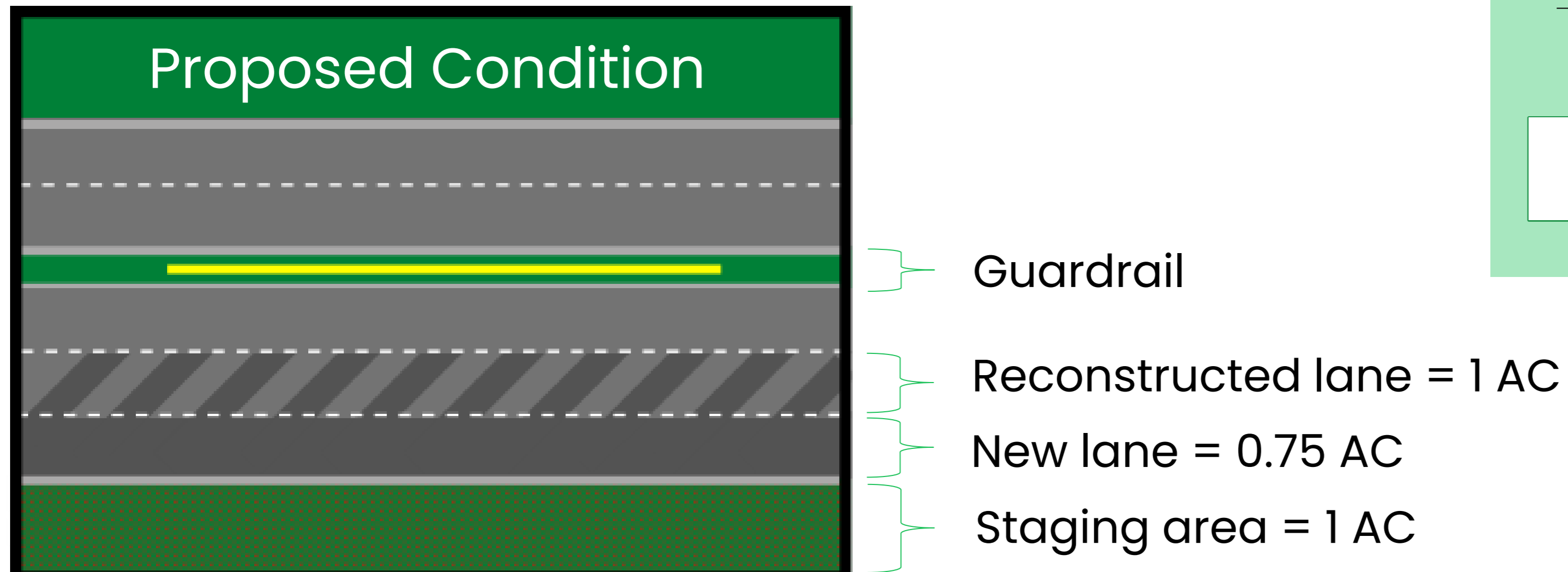
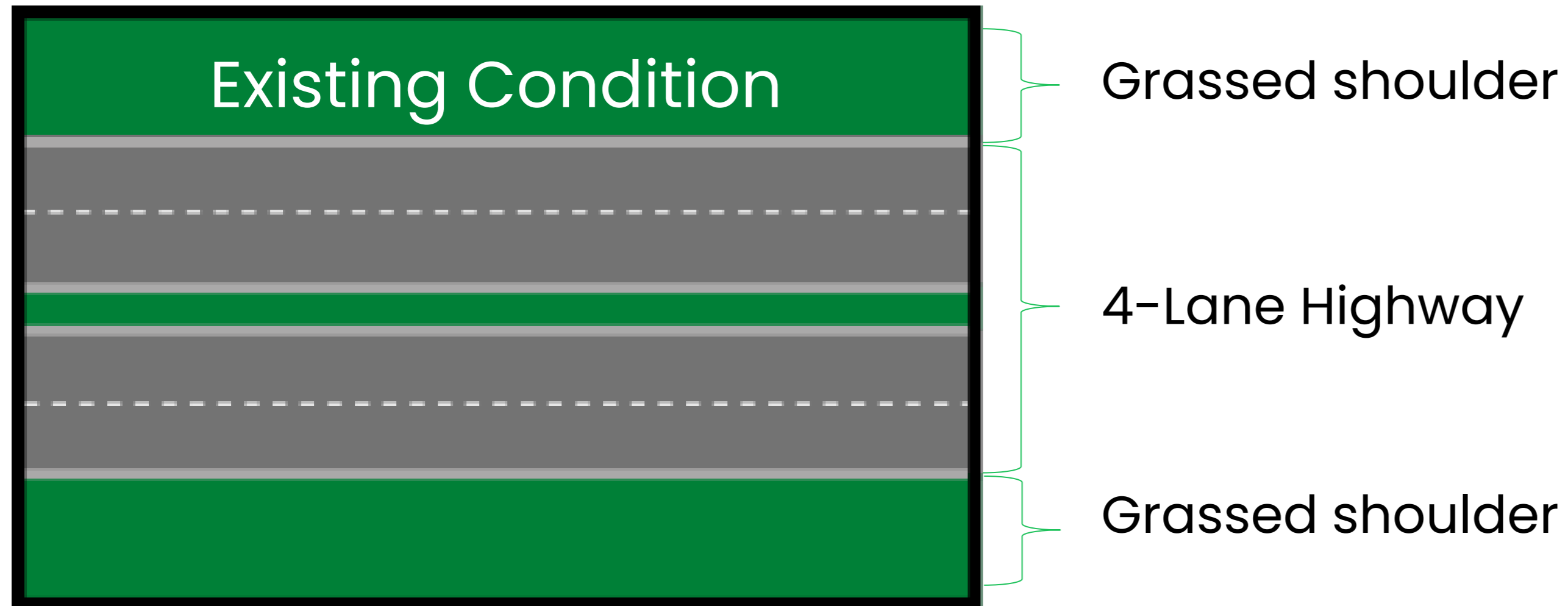

All public construction projects that result in one (1) acre or more of **Disturbed Area** are required to implement LID BMPs

Project location = Oahu (MS4 Permit Area)

1 new lane constructed	= 0.75 AC
1 existing lane reconstructed	= 1 AC
Disturbed pervious area	= 1 AC
<b>Total Disturbed Area</b>	<b>= 2.75 AC</b>

**Are LID BMPs required?**



# DESIGN EXAMPLE #1

Public Project within DOT ROW (MS4 Permit Area)

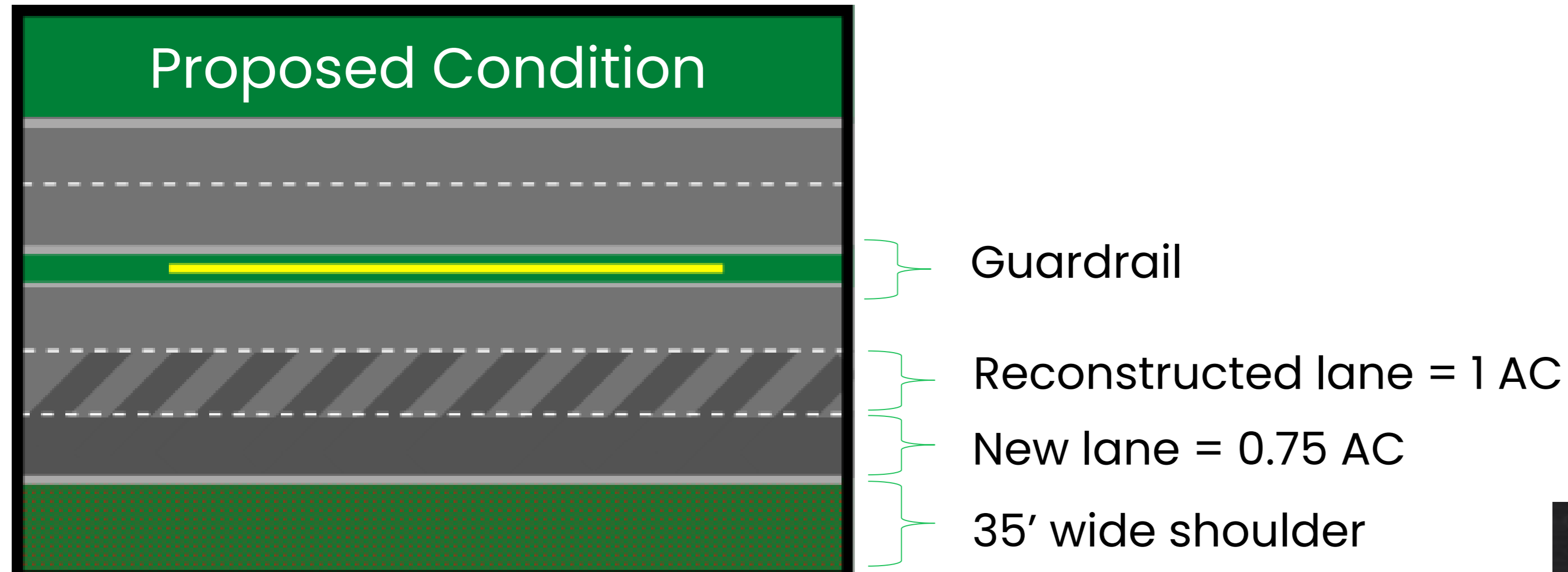

## Required Treatment Area ( $A_T$ )

$$\begin{aligned} A_T &= ND + (RD \times F) - A_{TE} \\ &= 0.75 + (1 \times 0.25) - 0 \\ &= 1.0 \text{ acres} \end{aligned}$$

$A_T$  = Required Treatment Area (AC)  
ND = New Development (AC)  
RD = Redevelopment (AC)  
F = Redevelopment Treatment Fraction  
= 0.25 for MS4 Permit Areas  
 $A_{TE}$  = Area Treated by Existing BMPs (AC)

# DESIGN EXAMPLE #1

## Public Project within DOT ROW (MS4 Permit Area)

### Post-Construction BMP Summary Matrix

- Prioritize LID BMPs
- Anticipate types of pollutants
- Estimate BMP footprint area and shape
- Select most appropriate BMP

Treatment Control BMP		Typical Targeted Pollutants for Removal						Notes
		Sediment <sup>1</sup>	Nutrients <sup>1</sup>	Oil & Grease <sup>2</sup>	Metals <sup>1</sup>	Trash <sup>2</sup>	Bacteria <sup>1</sup>	
LID	Vegetated Buffer Strip	x		x		x		
	Vegetated Swale	x		x		x		
	Enhanced Swale	x	x	x	x	x		
	Infiltration Trench	x	x	x	x	x	x	
	Infiltration Basin	x	x	x	x	x	x	
	Bioretention Facility	x	x	x	x	x	x	
	Permeable Pavement	x	x	x	x		n/a	
	Pocket Wetland	x	varies	x	x	x	x	
	Rainwater Harvesting	varies	varies	n/a	varies	n/a	varies	Primarily for runoff reduction
	Tree Box Filter	x	x	x	n/a	x	x	
TRADITIONAL NON-LID	Wet Pond	x	x	x	x	x	x	
	Wet Extended Detention Pond	x	x	x	x	x	x	
	Sand Filter	x	varies	x	x	x		

# DESIGN EXAMPLE #1

## Public Project within DOT ROW (MS4 Permit Area)



### Bioretention Facility



SOURCE: New Jersey Developers Green Infrastructure Guide 2018

#### Typical Targeted Pollutants for Removal

Sediment	X
Nutrients	X
Oil & Grease	X
Metals	X
Trash	X
Bacteria	X

#### Other Considerations <sup>1</sup>

Construction Cost	Moderate
Maintenance Cost	Moderate
Effective Life	5-20 years

<sup>1</sup> Source: Washington State DOT, Highway Runoff Manual 2019

#### Description & Purpose

Bioretention facilities are vegetated depressions where storm water runoff is directed through vegetation and designed soil mixes for infiltration and treatment. Soil mix may

T-6

# DESIGN EXAMPLE #1

## Public Project within DOT ROW (MS4 Permit Area)

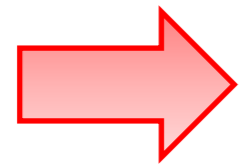

### Limitations (continued)

- Should not be used for treatment of industrial runoff to avoid groundwater contamination.
- Bioretention facility shall be located at least 100 feet from any water supply well or septic system leach field.
- Bioretention facility should not be placed in locations that cause water problems to adjacent properties or roadways and should be setback (10 ft) downgrade from structures.
- Maintain at least 3 feet clearance between the bottom of the bioretention facility and the seasonally high groundwater table to avoid groundwater contamination.

### Design Criteria

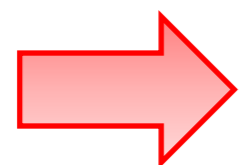

#### SIZING PROCEDURE

1. Determine the Water Quality Volume (WQV).
2. Pretreatment is critical to capture sediment that may otherwise clog the soil media layer. Size the pretreatment forebay assuming a volume equal to 10 percent of the WQV (DOEE 2020). The forebay volume counts toward the WQV requirement.

$$V_p = 0.1WQV$$

Where  $V_p$  = Pretreatment Forebay Volume (ft<sup>3</sup>)

# DESIGN EXAMPLE #1

Public Project within DOT ROW (MS4 Permit Area)

## Step 1: Determine Water Quality Volume (WQV)

$$WQV = P \times C \times A_T \times 3630$$

Where WQV = Water Quality Volume (ft<sup>3</sup>)

P = Design Storm Runoff Depth (inches) = 1 inch

C = Volumetric Runoff Coefficient = 0.95

A<sub>T</sub> = Treatment Area (ac) = 1 AC

3630 = conversion factor

$$\begin{aligned} WQV &= 1 \times 0.95 \times 1.0 \times 3630 \\ &= \underline{3,448.5 \text{ ft}^3} \end{aligned}$$

# DESIGN EXAMPLE #1

Public Project within DOT ROW (MS4 Permit Area)

## Step 2: Determine pretreatment volume ( $V_p$ )

$$V_p = 10\% \text{ of } WQV$$

Where  $V_p$  = Pretreatment Volume ( $\text{ft}^3$ )

$$\begin{aligned} V_p &= 0.10 \times 3448.5 \text{ ft}^3 \\ &= \underline{344.85 \text{ ft}^3} \end{aligned}$$

Pretreatment volume counts toward the WQV requirement so remaining volume to be treated is

$$(3,448.5 - 344.85) = \underline{3,103.65 \text{ ft}^3}$$



# DESIGN EXAMPLE #1

Public Project within DOT ROW (MS4 Permit Area)

## Step 3: Determine the maximum storage depth ( $d_{max}$ )

$$d_{max} = \frac{kt}{12FS}$$

Where $d_{max}$ = Maximum Storage Depth (ft)	<u>Typical</u>	<u>Assumed</u>
k = Soil Infiltration Rate from testing (in/hr)		4 in/hr
t = Drawdown Time (hours)	48 hrs	48 hrs
FS = Infiltration Rate Factor of Safety (to account for long-term reduction due to clogging)	2	2

$$d_{max} = \frac{(4)(48)}{(12)(2)} = \underline{8 \text{ feet}}$$

# DESIGN EXAMPLE #1

Public Project within DOT ROW (MS4 Permit Area)

**Step 4: Determine the total effective storage depth ( $d_t$ )**

$$d_t = dp + d_m n_m + d_d n_d$$

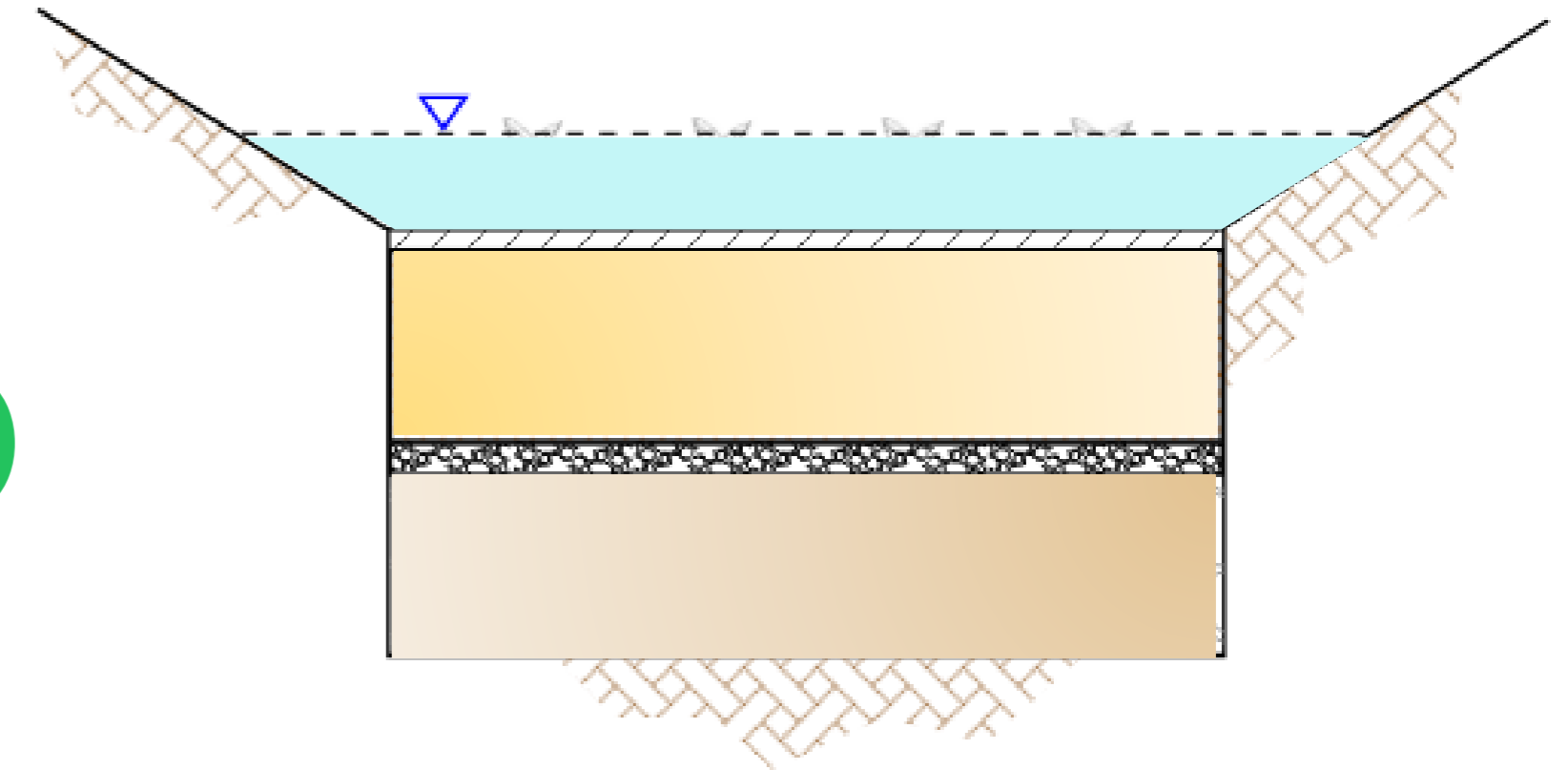

Where $d_t$ = Total Effective Storage Depth (ft)	<u>Typical</u>	<u>Assumed</u>
$d_p$ = Max. Ponding Depth (ft)	0.5 ft	0.5 ft
$d_m$ = Planting Media Depth (ft)	2-4 ft	3 ft
$n_m$ = Planting Media Porosity	0.2-0.35	0.3
$d_d$ = Drainage Layer Depth (ft)	0.67-1.0 ft	1 ft
$n_d$ = Drainage Layer Porosity	0.3-0.4	0.4

$$\begin{aligned}d_t &= 0.5 + (3)(0.3) + (1)(0.4) \\ &= \underline{1.8 \text{ feet}} < \text{max. storage depth of } 8'\end{aligned}$$



# DESIGN EXAMPLE #1

Public Project within DOT ROW (MS4 Permit Area)

## Step 5: Determine the required bottom surface area ( $A_b$ )

$$A_b = \frac{0.9 \times WQV}{d_t + kT / 12FS}$$

Where $A_b$ = Bottom Surface Area (ft <sup>2</sup> )	<u>Typical</u>	<u>Assumed</u>
WQV = Water Quality Volume (ft <sup>3</sup> )		
$d_t$ = Total Effective Storage Depth (ft)		
k = Soil Infiltration Rate (in/hr)		6 in/hr
T = Fill Time (hours)	2 hrs	2 hrs
FS = Infiltration Rate Factor of Safety	2	2

$$A_b = \frac{0.9 \times 3448.5}{1.8 + (6)(2)/(12)(2)} = \underline{1,349.41 \text{ ft}^2}$$

# DESIGN EXAMPLE #1

Public Project within DOT ROW (MS4 Permit Area)

## Step 6: Determine the bottom width ( $w_b$ )

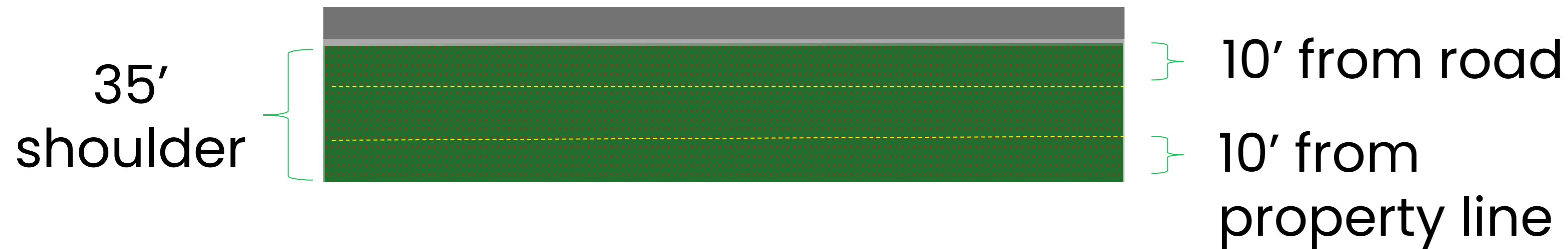

$$w_t = [w_b + 2z(d_p)] = 15' (max)$$

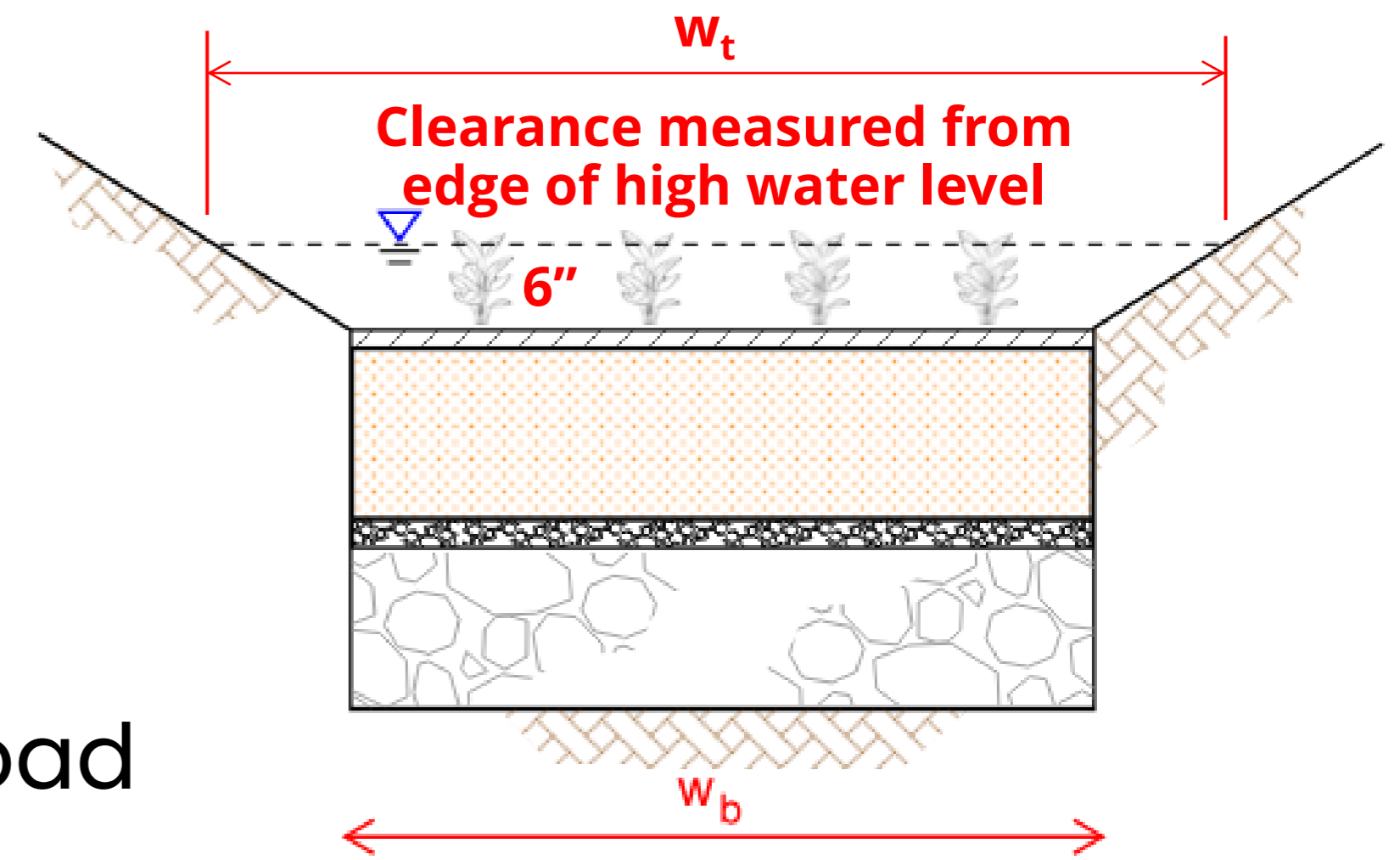

Where $w_t$ = Width at high water level (ft)	<u>Typical</u>	<u>Assumed</u>
$w_b$ = Bottom Width (ft)		
$z$ = Side Slope (length per unit height)	3H:1V 2H:1V (max)	3H:1V
$d_p$ = Design Ponding Depth (ft)	0.5 ft	0.5 ft

$$w_t = 15 = [w_b + (2)(3)(0.5)] \quad \rightarrow \quad \text{Bottom width } (w_b) = \underline{12'}$$

# DESIGN EXAMPLE #1

Public Project within DOT ROW (MS4 Permit Area)

**Step 7: Determine the required bottom length ( $l_b$ )**

$$l_b = \frac{A_b}{W_b}$$

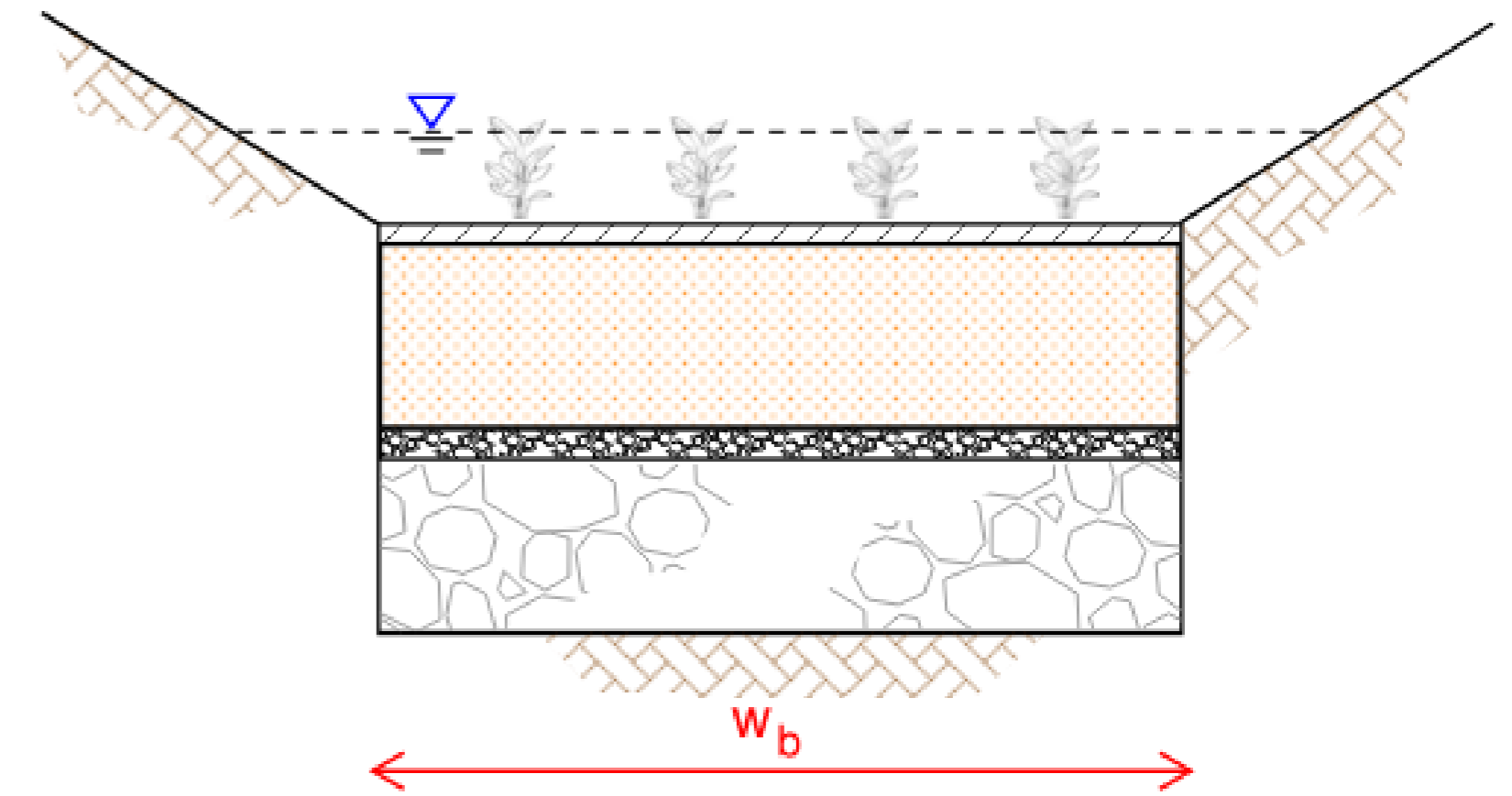

Where $l_b$ = Bottom Length (ft)	<u>Typical</u>	<u>Assumed</u>
$A_b$ = Bottom Surface Area		rectangular
$w_b$ = Bottom Width (ft)		12'

$$l_b = \frac{1,349.41}{12} = \underline{112.45 \text{ ft}}$$

# DESIGN EXAMPLE #1

Public Project within DOT ROW (MS4 Permit Area)

## Step 8: Determine the total surface area ( $A_{BMP}$ )

$$A_{BMP} = [w_b + 2z(d_p + f)] \times [l_b + 2z(d_p + f)]$$

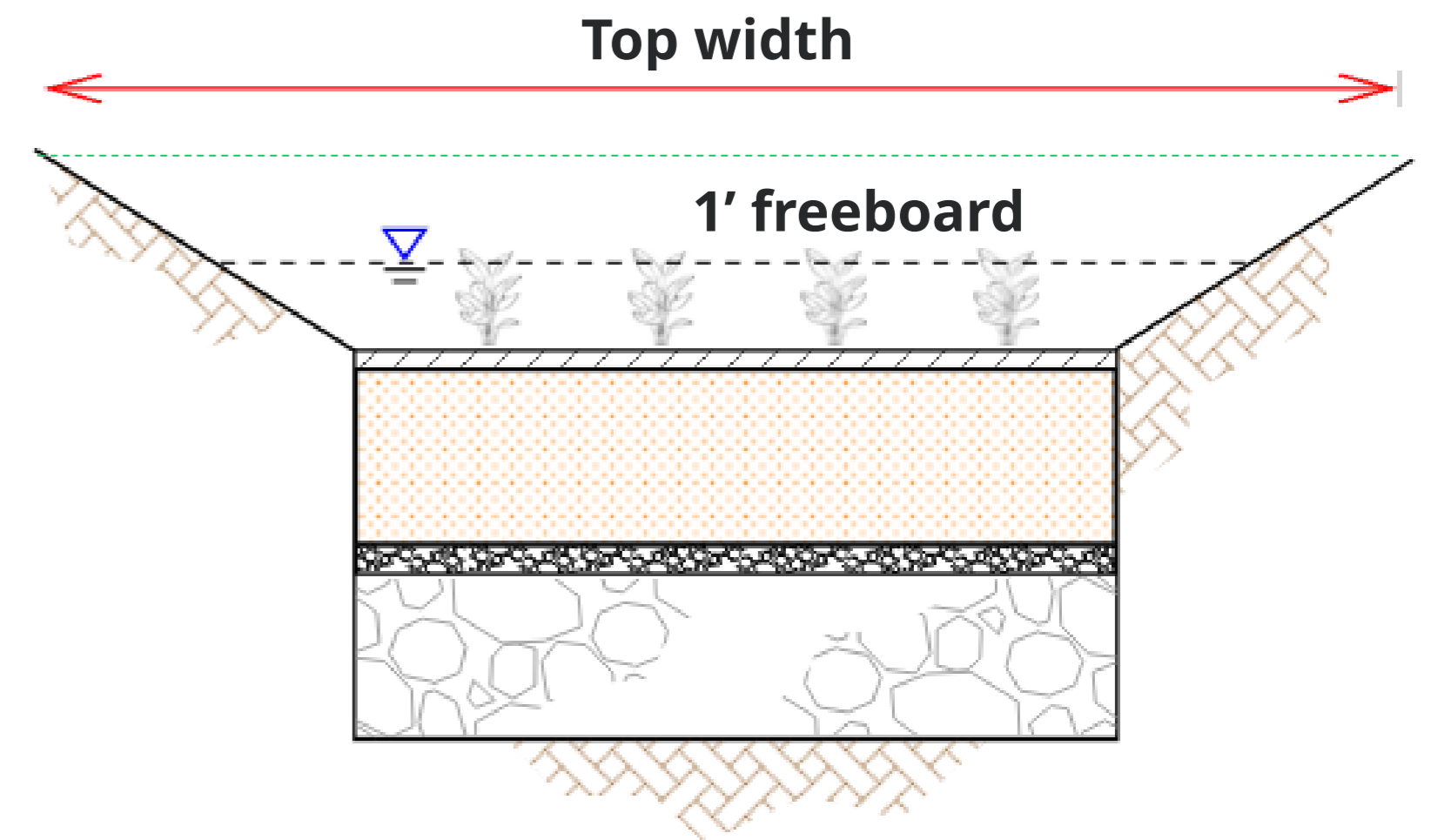

Where $A_{BMP}$ = Total Surface Area (ft <sup>2</sup> )	<u>Typical</u>	<u>Assumed</u>
$w_b$ = Bottom Width (ft)		12 ft
$z$ = Side Slope (length per unit height)	3H:1V 2H:1V (max)	3H:1V
$l_b$ = Bottom Length (ft)		121.24 ft
$d_p$ = Design Ponding Depth (ft)	0.5 ft	0.5 ft
$f$ = Freeboard (ft)	1.0 ft	1.0 ft

$$\begin{aligned} A_{BMP} &= [12 + (2)(3)(0.5 + 1)] \times [(112.45) + (2)(3)(0.5 + 1)] \\ &= [21] \times [121.45] \\ &= 2,550.45 \text{ ft}^2 \end{aligned}$$

# DESIGN EXAMPLE #1

Public Project within DOT ROW (MS4 Permit Area)

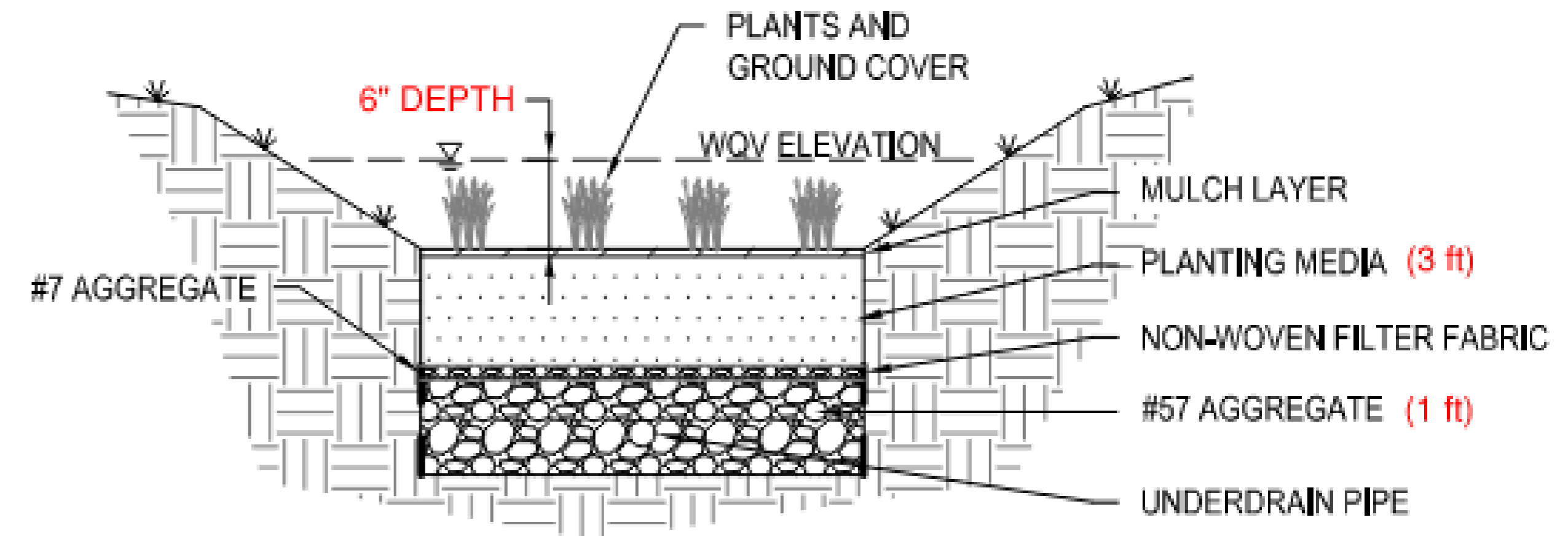
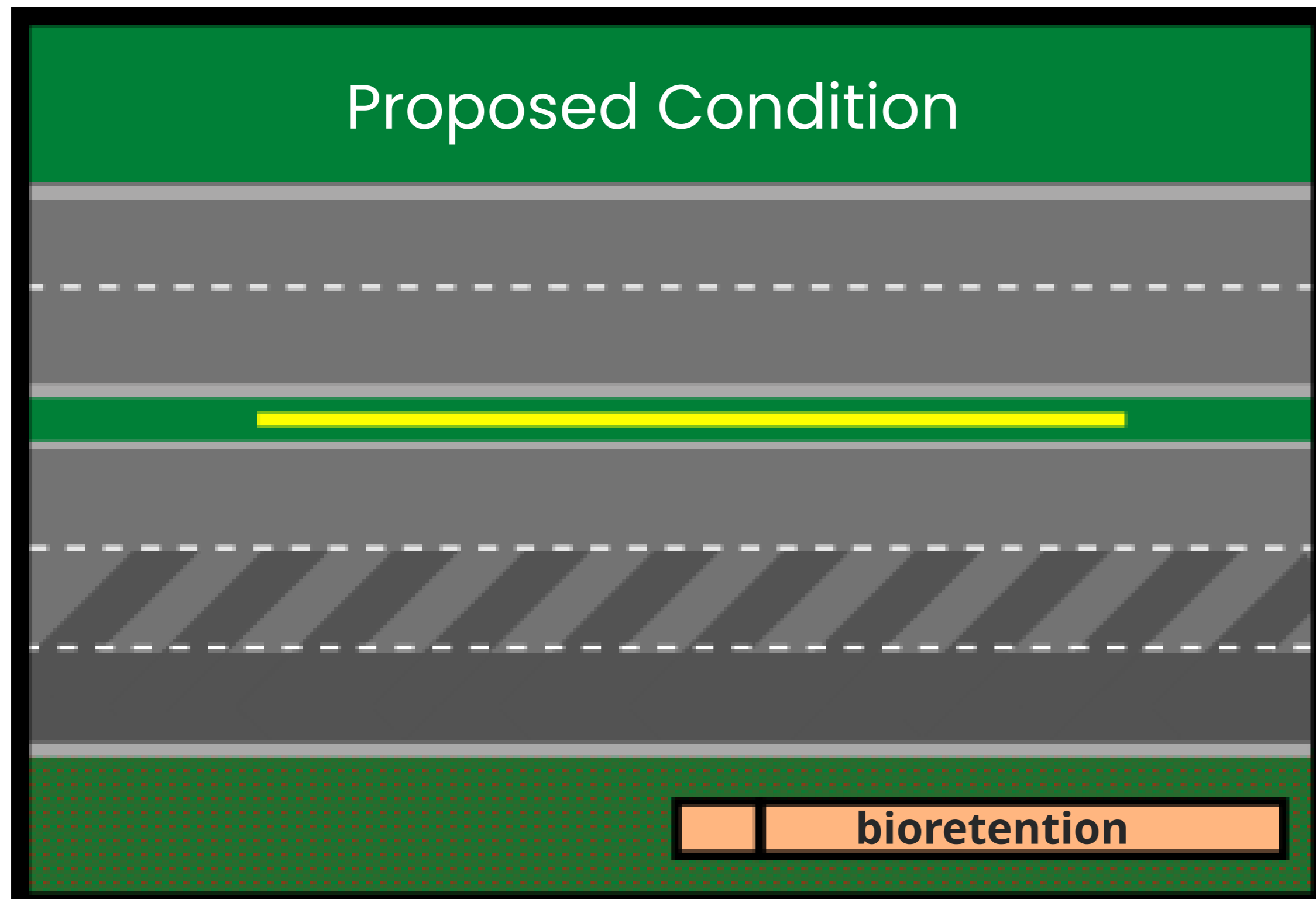

Proposed bioretention facility

Top width = 21'

Top length = 121.45'

$A_{BMP} = 2,550.45 \text{ ft}^2$

# POST-CONSTRUCTION BMP DESIGN CHECKLIST

STORM WATER POST-CONSTRUCTION BMP DESIGN CHECKLIST FOR MS4 PERMIT AREAS		<input checked="" type="checkbox"/> New Submittal <input type="checkbox"/> Resubmittal
Project Information		
Project Name: <u>12/25/22</u>		
Project Number: <u>HWY-0-88-88</u>	Island: <u>Oahu</u>	
Project Route Name(s): <u>12/25/22</u>	Milepost Begin/End: <u>1.0 - 2.2</u>	
Watershed Location(s): <u>KAWAII</u>		
Disturbance Area (acres): <u>2.75</u>	New Impervious Area (acres): <u>0.75</u>	
Applicant Name: _____	Company: _____	
Email: _____	Telephone: _____	

- Use the correct checklist
- Include watershed location(s)
- Disturbance area
- New impervious area
- Applicant name

# POST-CONSTRUCTION BMP DESIGN CHECKLIST

Applicability	
1. Check "Yes" if project entirely consists of one or more of the following activities or conditions below. The project may be exempt from Post-Construction BMPs if it includes these exempted activities <b>ONLY</b> . Otherwise, if the project includes other types of improvements not listed below, continue to Step 2.	Yes
a. Project does not result in storm water discharge into the MS4 or state waters	<input type="checkbox"/>
b. Operations and Maintenance activities	<input type="checkbox"/>
b.1 Structural repairs	<input type="checkbox"/>
b.2 Baseyard maintenance and repairs	<input type="checkbox"/>
b.3 Installation or replacement of pavement striping and pavement markers	<input type="checkbox"/>
b.4 Other _____	<input type="checkbox"/>
c. Pavement Preservation Treatment which does not expose or disturb underlying aggregate or subgrade layer	<input type="checkbox"/>
d. Guardrail and Underground Utility Projects	<input type="checkbox"/>
d.1 Guardrail installation or replacement	<input type="checkbox"/>
d.2 Utility installation or relocation	<input type="checkbox"/>
e. Water Quality Improvements or Preservation	<input type="checkbox"/>
e.1 Shoreline protection	<input type="checkbox"/>
e.2 Landscaping	<input type="checkbox"/>
e.3 Culvert rehabilitation or replacement	<input type="checkbox"/>
e.4 Installation of Post-Construction BMPs	<input type="checkbox"/>
e.5 Erosion and sediment control	<input type="checkbox"/>
e.6 Rockfall mitigation	<input type="checkbox"/>
f. Pedestrian walkways or bicycle paths	<input type="checkbox"/>
g. Bridges or roads constructed above or below existing impervious areas	<input type="checkbox"/>

*do not check* →

*do not check* →

h. "Minor" Disturbance Project	Yes
h.1 Signage	<input type="checkbox"/>
h.2 ADA ramps	<input type="checkbox"/>
i. Emergency project	<input type="checkbox"/>
j. Temporary project	<input type="checkbox"/>

**If project ONLY consists of exempt activities, go to Step 7. Otherwise, continue to Step 2.**

- Since project involves non-exempt activities, none of the exemptions should be marked.
- Continue to Step 2

# POST-CONSTRUCTION BMP DESIGN CHECKLIST

<p>2. Is project a private construction project?</p> <p><input type="checkbox"/> <b>Yes; project is outside the DOT-HWYS right-of-way.</b> Post-construction BMPs must comply with the applicable county storm water requirements. Identify any county-required documentation below. Continue to Step 7.</p> <hr/> <p><input type="checkbox"/> <b>Yes; project is within DOT-HWYS right-of-way.</b> Post-construction BMPs may be required if project has the potential to discharge storm water to the DOT-HWYS right-of-way. Continue to Step 3.</p> <p><input checked="" type="checkbox"/> <b>No;</b> Continue to Step 3.</p>
<p>3. Does project result in one (1) acre or more of Disturbed Area?</p> <p><input checked="" type="checkbox"/> <b>Yes;</b> LID BMPs are required. Continue to Step 6.</p> <p><input type="checkbox"/> <b>No;</b> continue to Step 4.</p>
<p>4. Is project a Priority Project with a high potential for pollutant discharge?</p> <p><input type="checkbox"/> <b>Yes;</b> Post-Construction BMPs may be required at the discretion of DOT-HWYS regardless of the amount of Disturbed Area. Continue to Step 6.</p> <p><input type="checkbox"/> <b>No;</b> continue to Step 5.</p>
<p>5. Is project located within or drain to sensitive receiving waters?</p> <p><input type="checkbox"/> <b>Yes;</b> Post-Construction BMPs may be required at the discretion of DOT-HWYS regardless of the amount of Disturbed Area. Continue to Step 6.</p> <p><input type="checkbox"/> <b>No;</b> post-construction BMPs are not required. Continue to Step 7.</p>
<p>6. Does project treat the full Required Treatment Area?</p> <p><input checked="" type="checkbox"/> <b>Yes;</b> continue to Step 7.</p> <p><input type="checkbox"/> <b>No;</b> acceptance of water quality treatment to be determined pending DOT-HWYS review. Submit a Variance Request Form. Continue to Step 7.</p>
<p>7. Additional project information (optional):</p> <p>Signature: <u>    <i>A. Consultant</i>    </u>      Date: <u>    <i>12/25/22</i>    </u></p>
<p><u>For Department Use Only:</u></p> <p>Does project adequately address post-construction BMP requirements?</p> <p><input checked="" type="checkbox"/> <b>Yes; the project treats the full Required Treatment Areas or is designed to the MEP.</b></p> <p><input type="checkbox"/> <b>No; the project is not designed to the MEP.</b> Provide additional post-construction BMPs.</p> <p><input type="checkbox"/> <b>No; the project will result in a debit for water quality treatment and Alternative Compliance will be required for the remainder of the Required Treatment Area.</b></p> <p>Reviewed By: <u>    <i>SWMP Team</i>    </u>      Reviewed Date: <u>    <i>5/18/22</i>    </u></p>

- Continue with Steps 2 through 6 for projects that include non-exempted activities
- Add additional project information (optional)
- Signature and date (required)
- Reviewer will indicate whether project fulfills the treatment requirement or has been designed to the Maximum Extent Practicable (MEP)

# DESIGN EXAMPLE #2

## Public Project within DOT ROW with Alternative Compliance (MS4 Permit Area)

- Computing disturbed areas
- Computing Required Treatment Area
- Incorporating existing BMPs
- Selection and Design of LID BMP (Infiltration Trench)
- Selection and Design of Non-LID BMP (Hydrodynamic Separator)
- Computing deficit amount of treatment
- Completing the post-construction BMP Design Checklist
- Application of Alternative Compliance
  - Variance Request Form
  - Selection of alternate watershed

# DESIGN EXAMPLE #2

## Public Project within DOT ROW with Alternative Compliance (MS4 Permit Area)

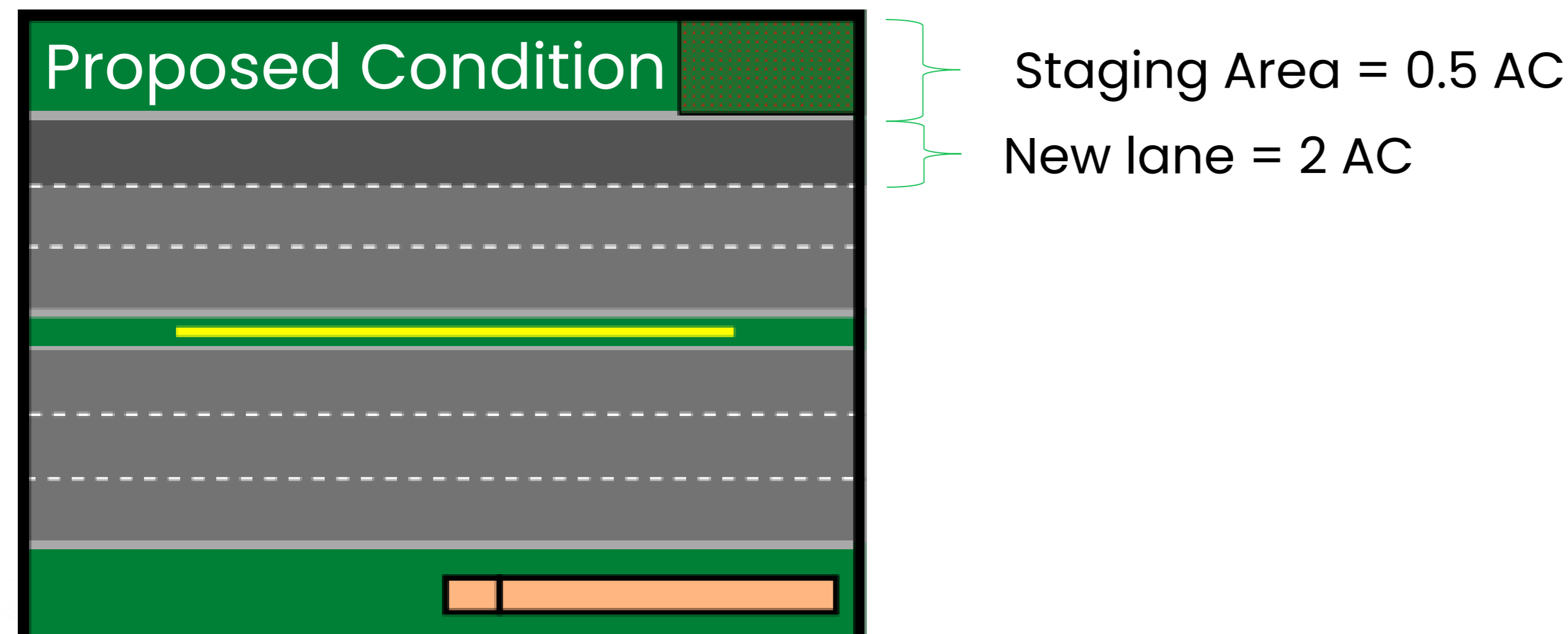
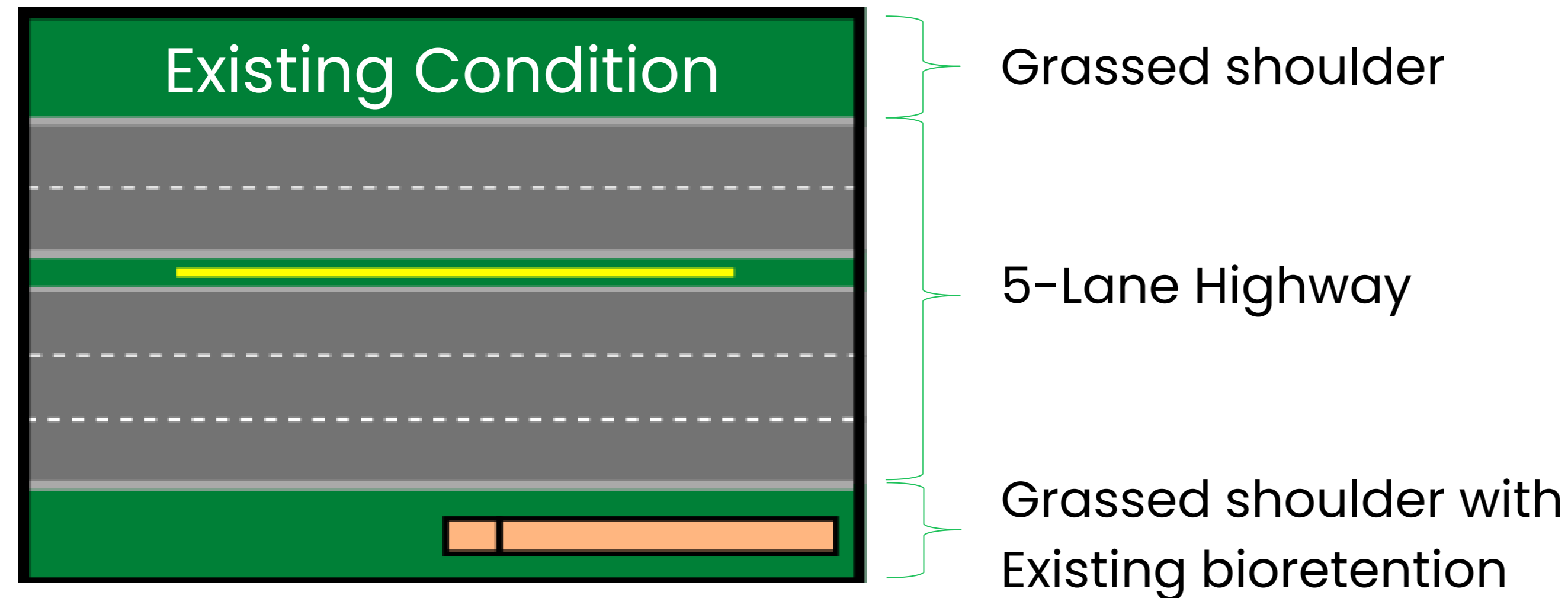

All public construction projects that result in one (1) acre or more of **Disturbed Area** are required to implement LID BMPs

Project location = Oahu (MS4 Permit Area)

1 new lane constructed	= 2 AC
1 existing lane reconstructed	= N/A
Disturbed pervious area	= 0.5 AC
<b>Total Disturbed Area</b>	<b>= 2.5 AC</b>

**Are LID BMPs required?**



# DESIGN EXAMPLE #2

## Public Project within DOT ROW with Alternative Compliance (MS4 Permit Area)

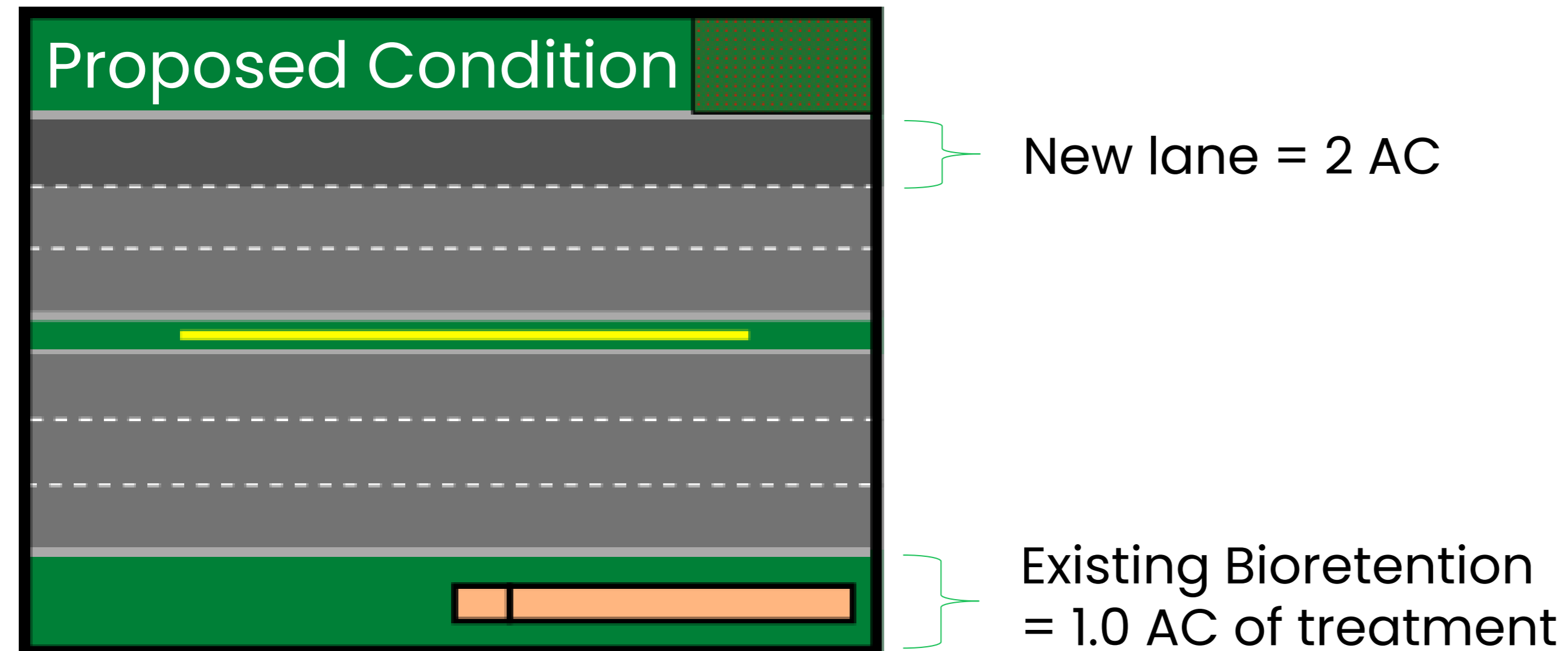

### Required Treatment Area ( $A_T$ )

$$\begin{aligned} A_T &= ND + (RD \times F) - A_{TE} \\ &= 2 + (0 \times 0.25) - 0 \\ &= 2.0 \text{ acres} \end{aligned}$$

$A_T$  = Required Treatment Area (AC)  
ND = New Development (AC)  
RD = Redevelopment (AC)  
F = Redevelopment Treatment Fraction  
= 0.25 for MS4 Permit Areas  
 $A_{TE}$  = Area Treated by Existing BMPs (AC)

# DESIGN EXAMPLE #2

## Public Project within DOT ROW with Alternative Compliance (MS4 Permit Area)



### Infiltration Trench

T-4



SOURCE: Virginia Association of Soil and Water Conservation District

Typical Targeted Pollutants for Removal	
Sediment	X
Nutrients	X
Oil & Grease	X
Metals	X
Trash	X
Bacteria	X

Other Considerations <sup>1</sup>	
Construction Cost	Low
Maintenance Cost	Low
Effective Life	20-50 years

<sup>1</sup> Source: Washington State DOT, Highway Runoff Manual 2019

#### Description & Purpose

An infiltration trench is a rock-filled trench with no surface outlet, where storm water runoff is stored in the void space between rocks and infiltrates through the bottom into the underlying soil matrix.

# DESIGN EXAMPLE #2

Public Project within DOT ROW with Alternative Compliance (MS4 Permit Area)

## Step 1: Determine Water Quality Volume (WQV)

$$WQV = P \times C \times A_T \times 3630$$

Where WQV = Water Quality Volume (ft<sup>3</sup>)

P = Design Storm Runoff Depth (inches) = 1 inch

C = Volumetric Runoff Coefficient = 0.95

A<sub>T</sub> = Treatment Area (ac) = 2 AC

3630 = conversion factor

$$\begin{aligned} WQV &= 1 \times 0.95 \times 2.0 \times 3630 \\ &= \underline{6,897 \text{ ft}^3} \end{aligned}$$

# DESIGN EXAMPLE #2

Public Project within DOT ROW with Alternative Compliance (MS4 Permit Area)

## Step 2: Determine pretreatment volume ( $V_p$ )

$$V_p = 10\% \text{ of } WQV$$

Where  $V_p$  = Pretreatment Volume ( $\text{ft}^3$ )

$$\begin{aligned} V_p &= 0.10 \times 6,897 \text{ ft}^3 \\ &= \underline{689.7 \text{ ft}^3} \end{aligned}$$

Pretreatment volume counts toward the WQV requirement so remaining volume to be treated is

$$(6,897 - 689.7) = \underline{6,207.30 \text{ ft}^3}$$

# DESIGN EXAMPLE #2

Public Project within DOT ROW with Alternative Compliance (MS4 Permit Area)

## Step 3: Determine the maximum storage depth ( $d_{max}$ )

$$d_{max} = \frac{kt}{12FS}$$

Where $d_{max}$ = Maximum Storage Depth (ft)	<u>Typical</u>	<u>Assumed</u>
k = Soil Infiltration Rate from testing (in/hr)		4 in/hr
t = Drawdown Time (hours)	48 hrs	48 hrs
FS = Infiltration Rate Factor of Safety (to account for long-term reduction due to clogging)	2	2

$$d_{max} = \frac{(4)(48)}{(12)(2)} = \underline{8 \text{ feet}}$$

# DESIGN EXAMPLE #2

Public Project within DOT ROW with  
Alternative Compliance (MS4 Permit Area)

## Step 4: Determine the total effective storage depth ( $d_t$ )

$$d_t = d_g n_g + d_r n_r + d_s n_s$$

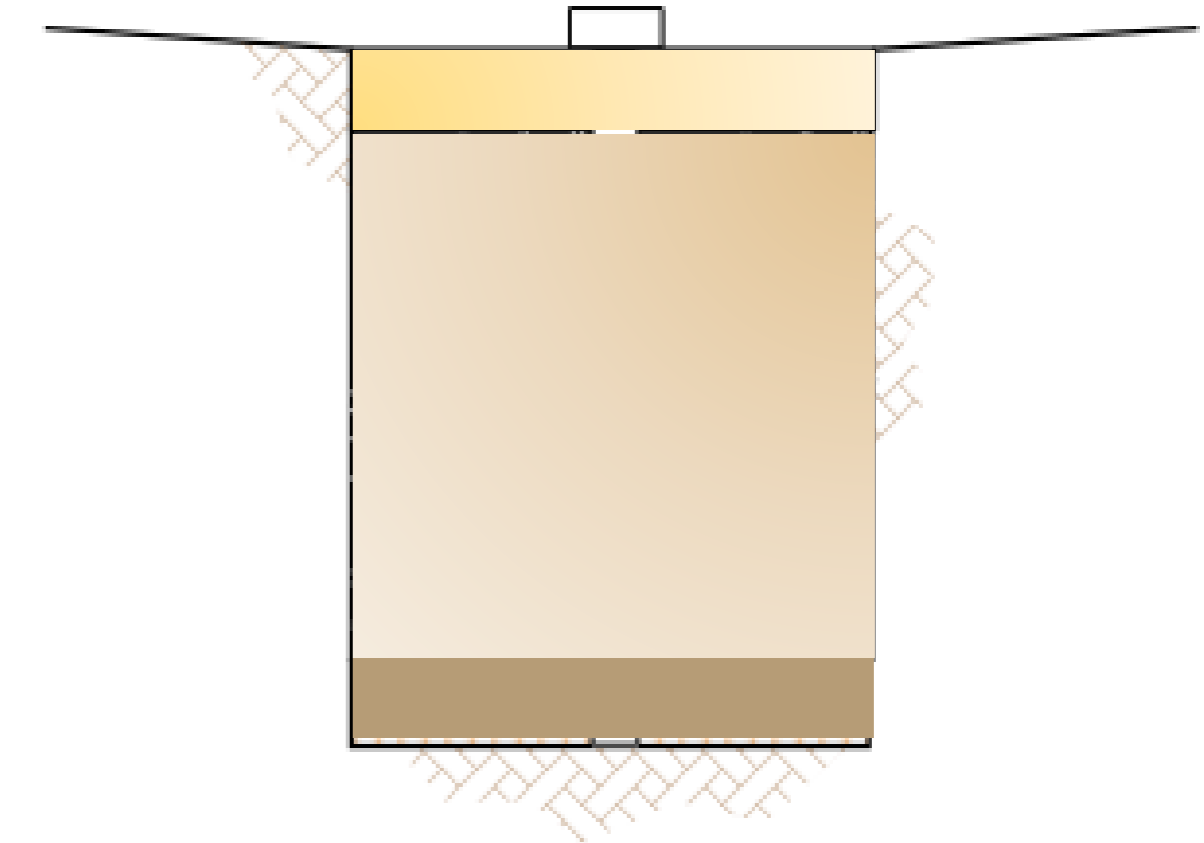

Where $d_t$ = Total Effective Storage Depth (ft)	<u>Typical</u>	<u>Assumed</u>
$d_g$ = Top Aggregate Layer Depth (ft)	0.5 ft	0.5 ft
$n_g$ = Top Aggregate Layer Porosity	0.2 to 0.35	0.3
$d_r$ = Rock Storage Layer Depth (ft)	2-10 ft	3 ft
$n_r$ = Rock Storage Layer Porosity	0.3-0.4	0.3
$d_s$ = Sand Layer Depth (ft)	0.5-1 ft	1 ft
$n_s$ = Sand Layer Porosity	0.25-0.45	0.4

$$d_t = (0.5)(0.3) + (3)(0.3) + (1)(0.4)$$

$$= \underline{1.45 \text{ feet}} < \text{max. storage depth of 8'}$$



# DESIGN EXAMPLE #2

Public Project within DOT ROW with Alternative Compliance (MS4 Permit Area)

## Step 5: Determine the required bottom surface area ( $A_b$ )

$$A_{BMP} = \frac{0.9 \times WQV}{\left(d_t + \frac{kT}{12FS}\right)}$$

Where $A_{BMP}$ = Bottom Surface Area (ft <sup>2</sup> )	<u>Typical</u>	<u>Assumed</u>
WQV = Water Quality Volume (ft <sup>3</sup> )		6,897 ft <sup>3</sup>
$d_t$ = Total Effective Storage Depth (ft)		1.45 ft
k = Soil Infiltration Rate (in/hr)		4 in/hr
T = Fill Time (hours)	2 hrs	2 hrs
FS = Infiltration Rate Factor of Safety	2	2

$$A_{BMP} = \frac{0.9 \times 6,897}{\left(1.45 + \frac{(4)(2)}{(12)(2)}\right)} = \underline{3,480.73 \text{ ft}^2}$$

# DESIGN EXAMPLE #2

Public Project within DOT ROW with Alternative Compliance (MS4 Permit Area)

## Step 6: Determine the required bottom length (L)

$$L = \frac{A_{BMP}}{W}$$

Where L = Bottom Length (ft)	<u>Typical</u>	<u>Assumed</u>
$A_{BMP}$ = Bottom Surface Area		rectangular
w = Bottom Width (ft)		12'

$$L = \frac{3,480.73}{12} = \underline{290.06 \text{ ft}}$$

# DESIGN EXAMPLE #2

## Public Project within DOT ROW with Alternative Compliance (MS4 Permit Area)

### Step 7: Assess site constraints

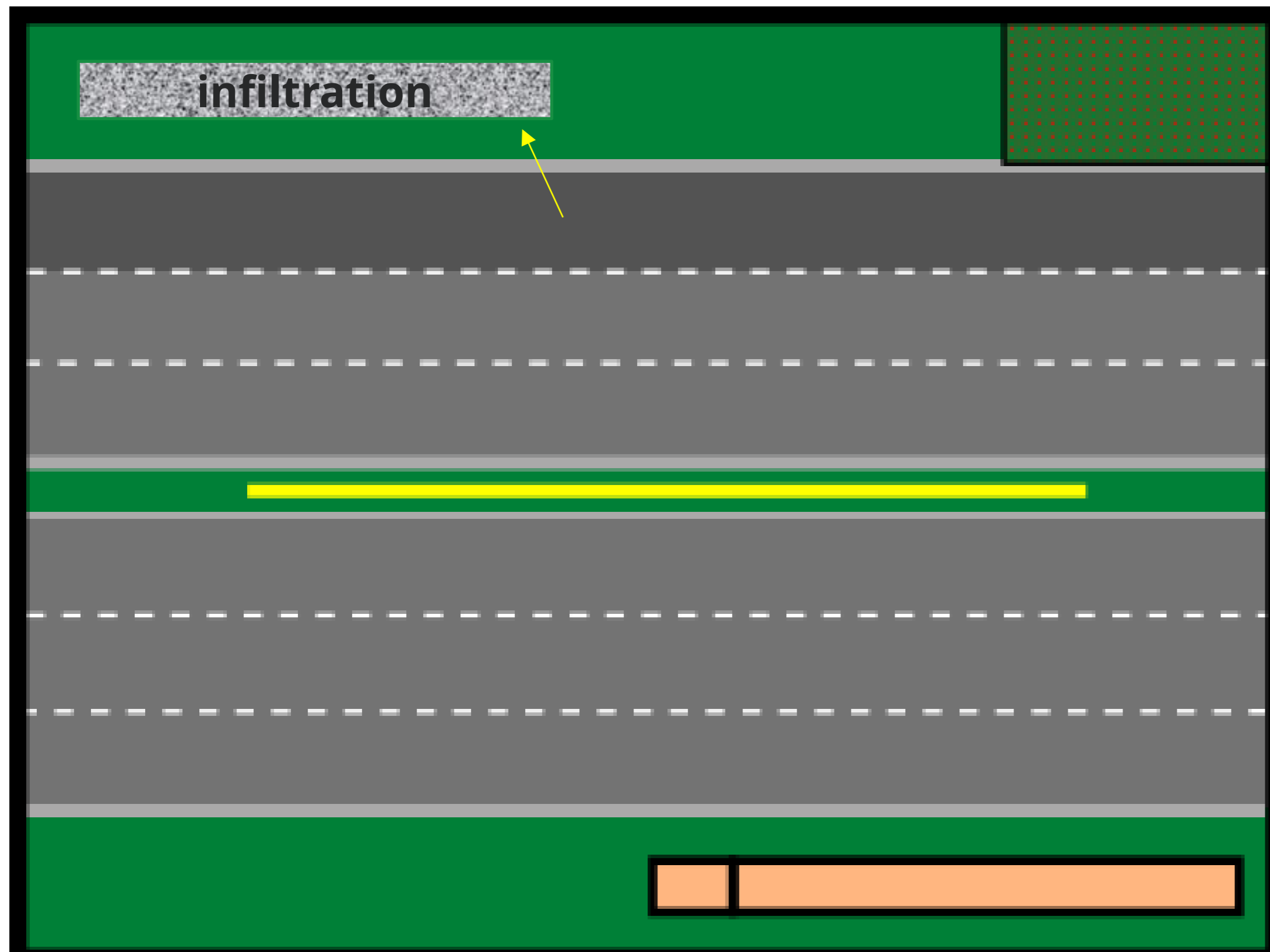

Required Length = 290.06 ft

- However, due to site constraints, longest length = 100 ft **Not enough space!**
- Back check to see how much treatment is provided with 100' length
- Actual  $A_{BMP} = 12' \text{ wide} \times 100' \text{ long}$   
 $= 1,200 \text{ ft}^2$

$$A_{BMP} = \frac{0.9 \times WQV}{\left(d_t + \frac{kT}{12FS}\right)}$$

→ WQV provided by infiltration trench  
 $= 2,377.78 \text{ ft}^3$

# DESIGN EXAMPLE #2

Public Project within DOT ROW with Alternative Compliance (MS4 Permit Area)

## Step 8: Calculate additional treatment required

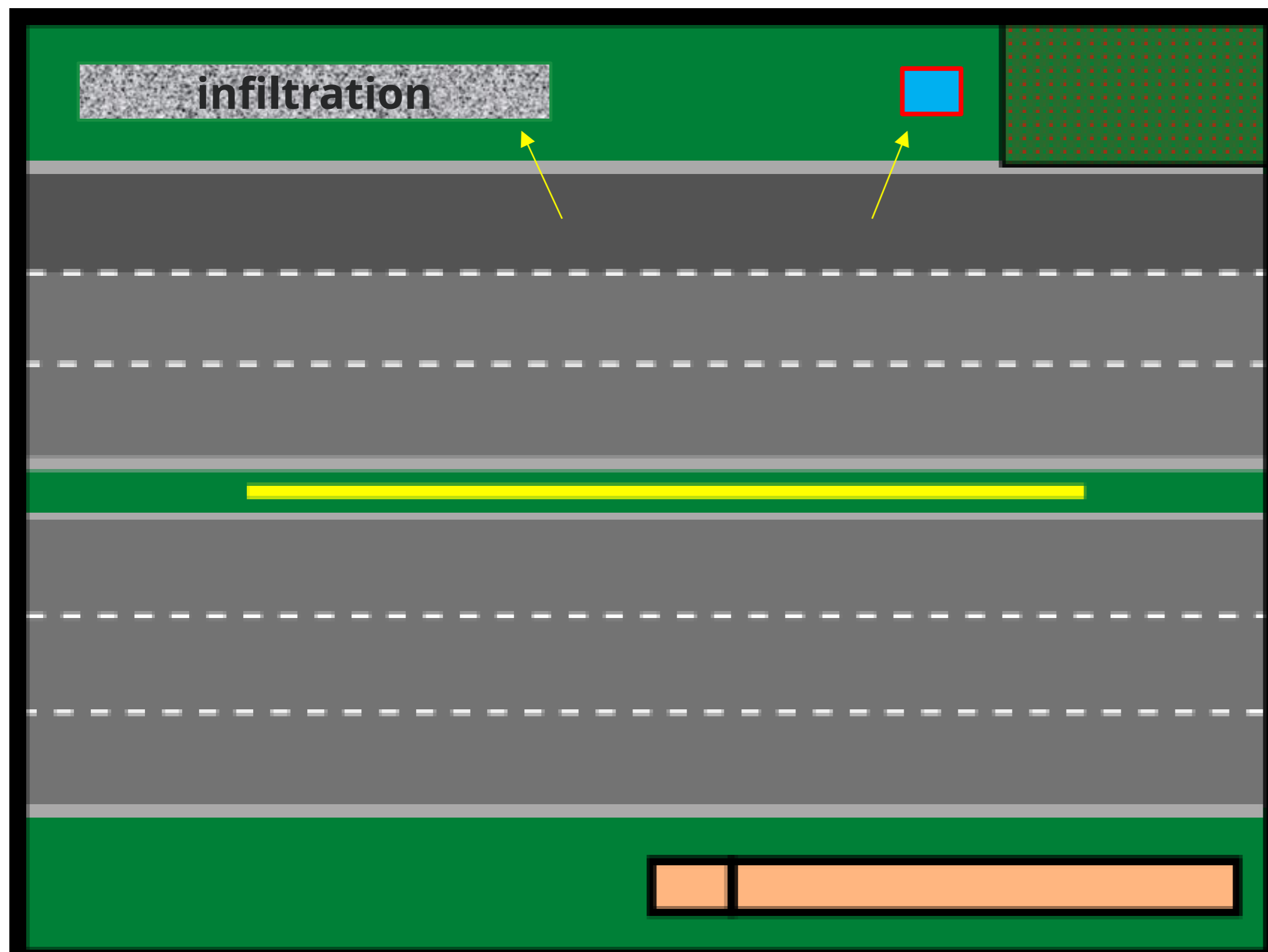

→ WQV provided by infiltration trench  
= 2,377.78 ft<sup>3</sup>

$$WQV = P \times C \times A_T \times 3630$$

→ Area Treated ( $A_T$ ) = 0.69 AC

→ Required Treatment Area = 2.0 AC

→ Additional Treatment Area Req'd =  
(2.0 - 0.69) AC = 1.31 AC

# DESIGN EXAMPLE #2

Public Project within DOT ROW with Alternative Compliance (MS4 Permit Area)

## Step 9: Calculate type of additional treatment to provide

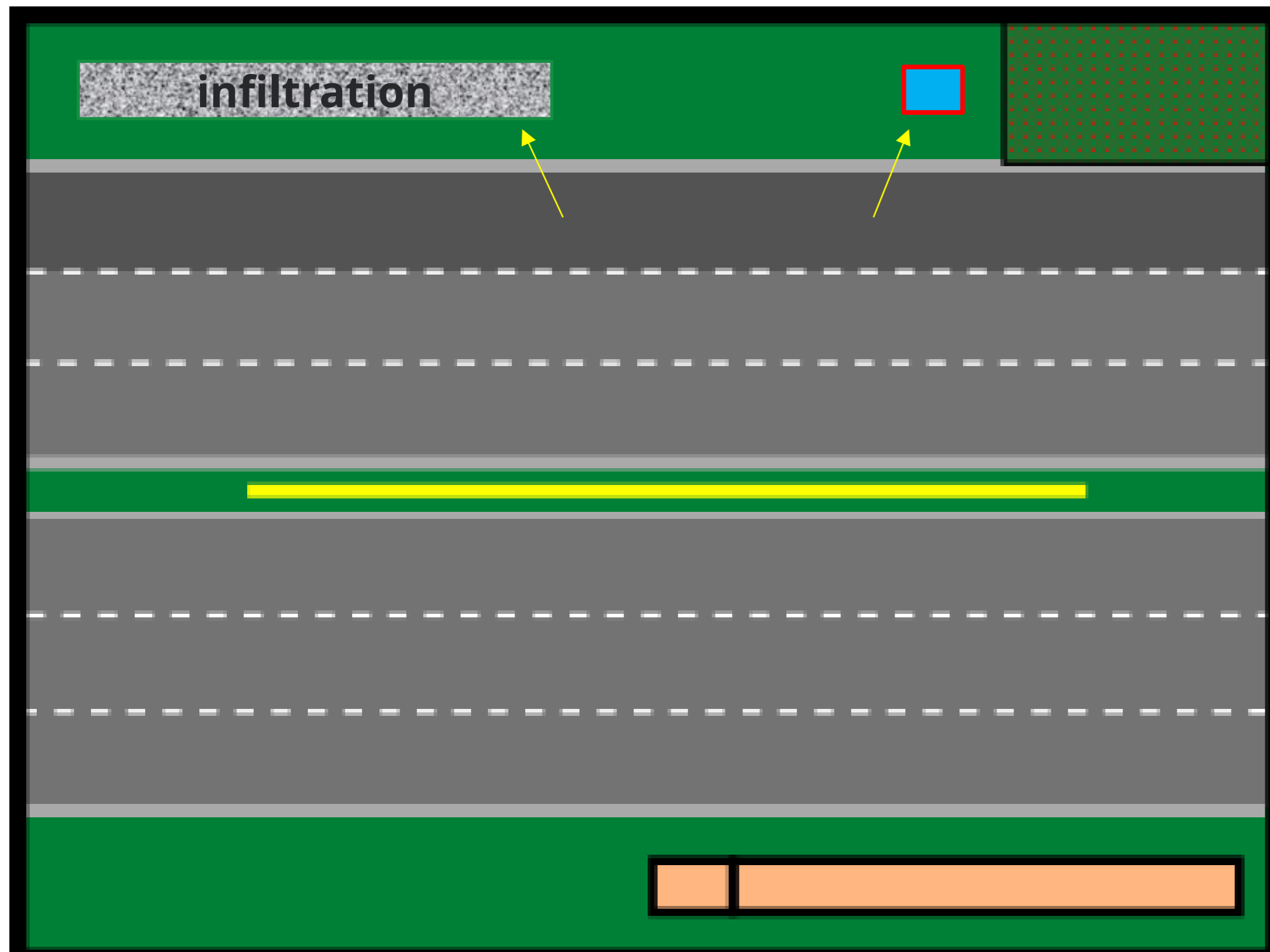

### Things to Consider

- Space constraints
- Combined post-construction BMPs
  - Volume-based
  - Flow-based

➔ Assume a flow-based BMP will be used

# DESIGN EXAMPLE #2

Public Project within DOT ROW with Alternative Compliance (MS4 Permit Area)

## Step 10: Determine Water Quality Flow Rate (WQFR) for remaining area

$$WQFR = C \times i \times A_T$$

Where WQFR = Water Quality Flow Rate (cfs)

C = Runoff Coefficient = 0.70 (asphalt pavement)

i = Rainfall Intensity (in/hr) = 0.4 in/hr

A<sub>T</sub> = Treatment Area (ac)

$$WQFR = 0.7 \times 0.4 \times 1.31$$

$$= \underline{0.37 \text{ cfs}} \quad \rightarrow \quad \text{size unit based on WQFR and peak flow}$$

→ Assume the entire 0.37 cfs cannot be treated so a variance will be required.

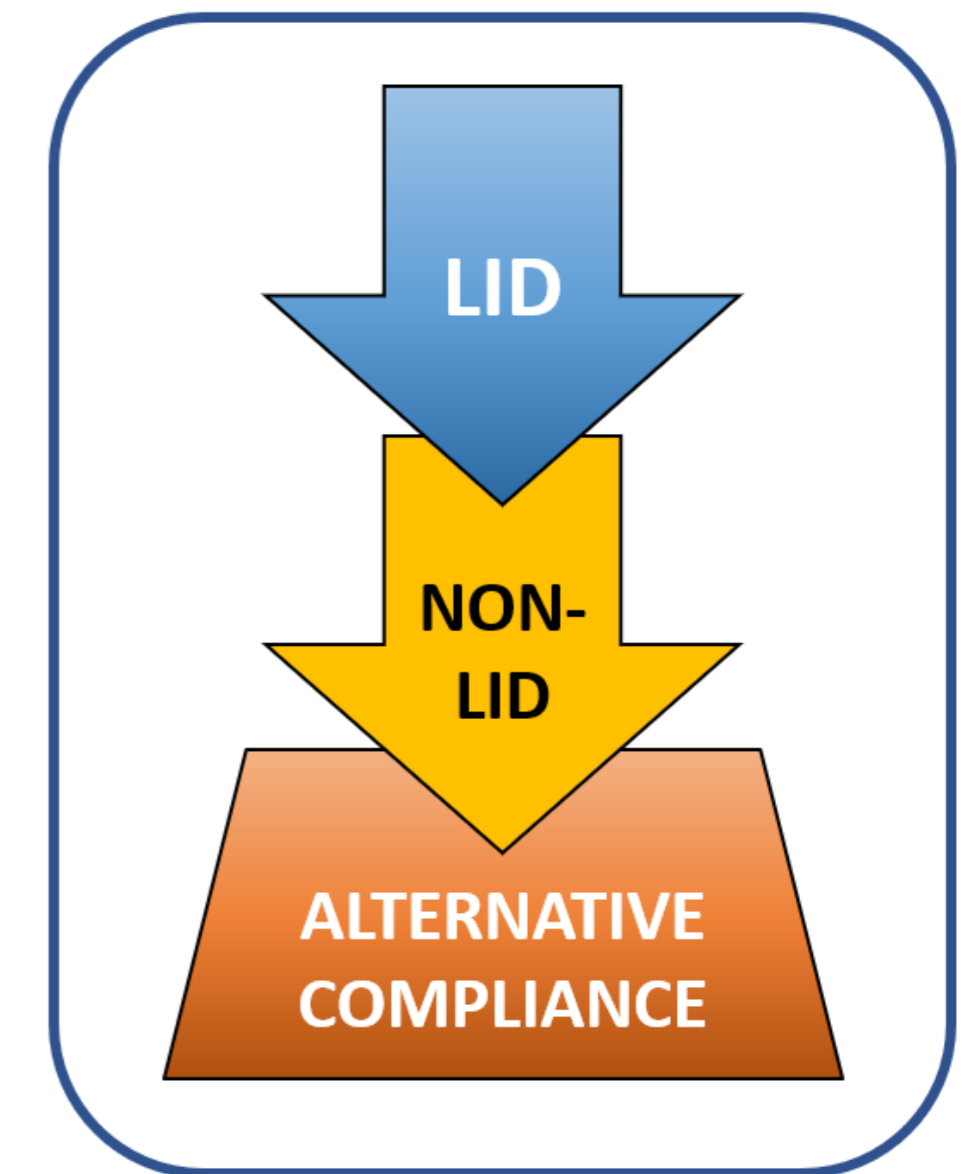

# POST-CONSTRUCTION BMP DESIGN CHECKLIST

Applicability	
1. Check "Yes" if project entirely consists of one or more of the following activities or conditions below. The project may be exempt from Post-Construction BMPs if it includes these exempted activities <b>ONLY</b> . Otherwise, if the project includes other types of improvements not listed below, continue to Step 2.	Yes
a. Project does not result in storm water discharge into the MS4 or state waters	<input type="checkbox"/>
b. Operations and Maintenance activities	<input type="checkbox"/>
b.1 Structural repairs	<input type="checkbox"/>
b.2 Baseyard maintenance and repairs	<input type="checkbox"/>
b.3 Installation or replacement of pavement striping and pavement markers	<input type="checkbox"/>
b.4 Other _____	<input type="checkbox"/>
c. Pavement Preservation Treatment which does not expose or disturb underlying aggregate or subgrade layer	<input type="checkbox"/>
d. Guardrail and Underground Utility Projects	<input type="checkbox"/>
d.1 Guardrail installation or replacement	<input type="checkbox"/> <i>do not check</i> →
d.2 Utility installation or relocation	<input type="checkbox"/>
e. Water Quality Improvements or Preservation	<input type="checkbox"/>
e.1 Shoreline protection	<input type="checkbox"/>
e.2 Landscaping	<input type="checkbox"/>
e.3 Culvert rehabilitation or replacement	<input type="checkbox"/>
e.4 Installation of Post-Construction BMPs	<input type="checkbox"/>
e.5 Erosion and sediment control	<input type="checkbox"/> <i>do not check</i> →
e.6 Rockfall mitigation	<input type="checkbox"/>
f. Pedestrian walkways or bicycle paths	<input type="checkbox"/>
g. Bridges or roads constructed above or below existing impervious areas	<input type="checkbox"/>

h. "Minor" Disturbance Project	Yes
h.1 Signage	<input type="checkbox"/>
h.2 ADA ramps	<input type="checkbox"/>
i. Emergency project	<input type="checkbox"/>
j. Temporary project	<input type="checkbox"/>

**If project ONLY consists of exempt activities, go to Step 7. Otherwise, continue to Step 2.**

- Since project involves non-exempt activities, none of the exemptions should be marked.
- Continue to Step 2

# POST-CONSTRUCTION BMP DESIGN CHECKLIST

2. Is project a private construction project? <input type="checkbox"/> <b>Yes; project is outside the DOT-HWYS right-of-way.</b> Post-construction BMPs must comply with the applicable county storm water requirements. Identify any county-required documentation below. Continue to Step 7. <hr/> <input type="checkbox"/> <b>Yes; project is within DOT-HWYS right-of-way.</b> Post-construction BMPs may be required if project has the potential to discharge storm water to the DOT-HWYS right-of-way. Continue to Step 3. <input checked="" type="checkbox"/> <b>No;</b> Continue to Step 3.
3. Does project result in one (1) acre or more of Disturbed Area? <input checked="" type="checkbox"/> <b>Yes;</b> LID BMPs are required. Continue to Step 6. <input type="checkbox"/> <b>No;</b> continue to Step 4.
4. Is project a Priority Project with a high potential for pollutant discharge? <input type="checkbox"/> <b>Yes;</b> Post-Construction BMPs may be required at the discretion of DOT-HWYS regardless of the amount of Disturbed Area. Continue to Step 6. <input type="checkbox"/> <b>No;</b> continue to Step 5.
5. Is project located within or drain to sensitive receiving waters? <input type="checkbox"/> <b>Yes;</b> Post-Construction BMPs may be required at the discretion of DOT-HWYS regardless of the amount of Disturbed Area. Continue to Step 6. <input type="checkbox"/> <b>No;</b> post-construction BMPs are not required. Continue to Step 7.
6. Does project treat the full Required Treatment Area? <input type="checkbox"/> <b>Yes;</b> continue to Step 7. <input checked="" type="checkbox"/> <b>No;</b> acceptance of water quality treatment to be determined pending DOT-HWYS review. Submit a Variance Request Form. Continue to Step 7.
7. Additional project information (optional):  Signature: <u>Jonathan Doe</u> Date: <u>12/25/22</u>
<u>For Department Use Only:</u> Does project adequately address post-construction BMP requirements? <input type="checkbox"/> <b>Yes; the project treats the full Required Treatment Areas or is designed to the MEP.</b> <input type="checkbox"/> <b>No; the project is not designed to the MEP.</b> Provide additional post-construction BMPs. <input checked="" type="checkbox"/> <b>No; the project will result in a debit for water quality treatment and Alternative Compliance will be required for the remainder of the Required Treatment Area.</b>
Reviewed By: <u>Jane Doe</u> Reviewed Date: <u>1/1/23</u>

- Continue with Steps 2 through 6 for projects that include non-exempted activities
- Add additional project information if desired
- Provide signature and date
- Reviewer will indicate whether project has been designed to the Maximum Extent Practicable (MEP)

**STORM WATER POST-CONSTRUCTION BMP  
VARIANCE REQUEST FORM**

**Project Information**

Project Name: \_\_\_\_\_

Project Number: \_\_\_\_\_ Island: \_\_\_\_\_

Project Route Name(s): \_\_\_\_\_ Milepost Begin/End: \_\_\_\_\_

Watershed Location(s): \_\_\_\_\_

Required Treatment Area (acres): \_\_\_\_\_ Provided Treatment Area (acres): \_\_\_\_\_

Applicant Name: \_\_\_\_\_ Company: \_\_\_\_\_

Email: \_\_\_\_\_ Telephone: \_\_\_\_\_

**Justification for Project Water Quality Debit**

1. Check "Yes" for any applicable project conditions below which will incur a debit(s).

	Yes
a. Where Low Impact Development (LID) BMPs are required, the designer shall implement LID BMPs to the Maximum Extent Practicable. Indicate any site constraints that will result in providing less than the required water quality treatment. Refer to Section 5.2 of the manual for further descriptions of the various types of constraints.	
a.1 Hydrogeological Constraint	<input type="checkbox"/>
a.2 Physical Constraint	<input checked="" type="checkbox"/>
a.3 Operational Constraint	<input type="checkbox"/>
a.4 Environmental/Cultural Constraint	<input type="checkbox"/>
a.5 Other Constraint Type _____	<input type="checkbox"/>
b. Project results in an increase in impervious area	<input type="checkbox"/>
c. Project will remove an existing post-construction BMP or reduce the treatment effectiveness of an existing post-construction BMP (reduction in associated WQV or WQFR)	<input type="checkbox"/>
d. Other _____	<input type="checkbox"/>

# VARIANCE REQUEST FORM

- Fill out if project does not treat the full Required Treatment Area
- Provide justification why adequate treatment cannot be provided
- Refer to Section 5.2 of the manual for further description of constraints
  - Hydrogeological
  - Physical
  - Operational
  - Environmental/Cultural
  - Other

# VARIANCE REQUEST FORM

2. Provide detailed information regarding the resulting project debits and indicate why full treatment cannot be met by using post-construction BMPs.

3. Indicate other information that will be provided to evaluate the justification of this variance request.

a. Design drawings or details	Yes <input checked="" type="checkbox"/>	No <input type="checkbox"/>
b. Calculations	Yes <input checked="" type="checkbox"/>	No <input type="checkbox"/>
c. Photos	Yes <input checked="" type="checkbox"/>	No <input type="checkbox"/>
d. Other	Yes <input type="checkbox"/>	No <input type="checkbox"/>

4. Applicant signature and date

Signature: \_\_\_\_\_ Date: \_\_\_\_\_

For Department Use Only: Variance Approved:  Denied:

Notes:

Reviewed By: \_\_\_\_\_ Reviewed Date: \_\_\_\_\_

- Provide justification why full treatment could not be met
- Provide supporting documentation
- If approved, project has been designed to MEP or Alternative Compliance will be needed to fulfill treatment requirement in another watershed.
- If denied, designer needs to re-evaluate design to provide more treatment

# DESIGN EXAMPLE #3

## Private Project partially within DOT ROW

- Computing disturbance area
- Determining Post-Construction BMP Requirements
  - Compliance with County requirements
  - Compliance with DOT requirements

# DESIGN EXAMPLE #3

## Private Project partially within DOT ROW

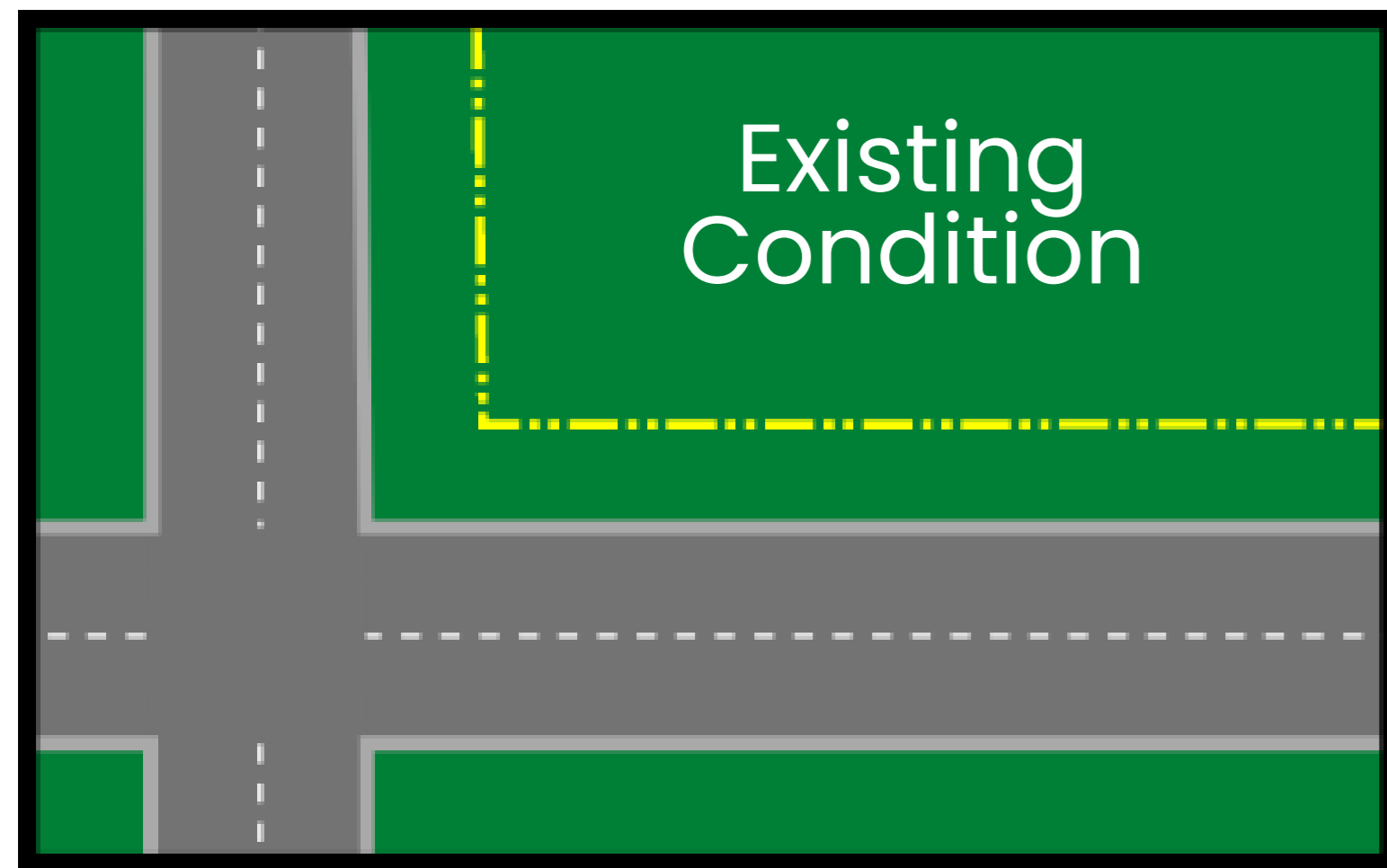

Undeveloped Private Property

DOT Right-of-Way

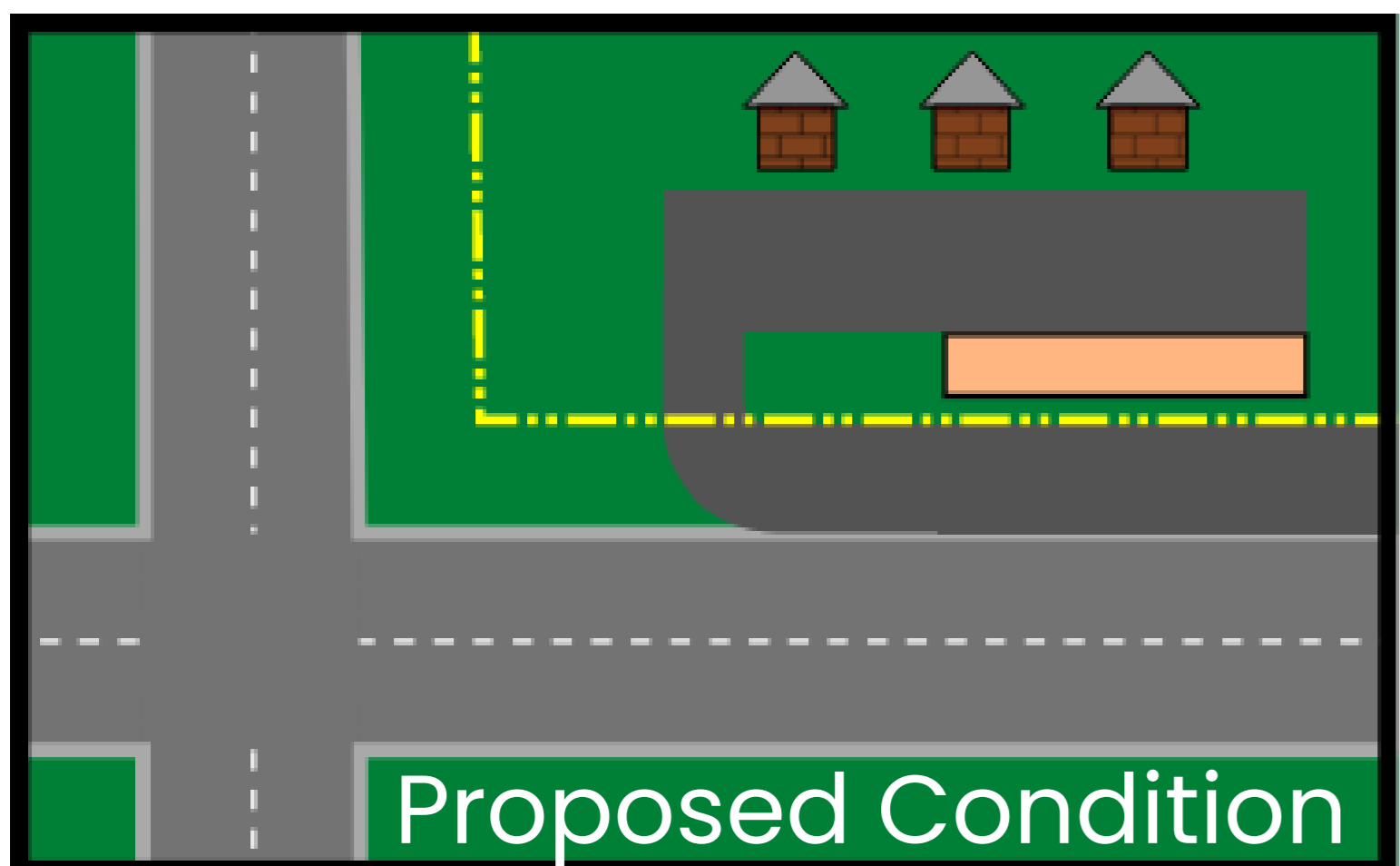

New Development with turning lane within DOT Right-of-Way

DOT Right-of-Way

**Post-construction BMPs may be required at the discretion of DOT-HWYS regardless of project size** for private construction projects located within the DOT-HWYS right-of-way **if the project has the potential to discharge storm water runoff to the DOT-HWYS right-of-way.**

Private construction projects located outside the DOT-HWYS right-of-way are considered to be in compliance with post-construction BMP requirements if the project **complies with the storm water quality requirements of the applicable county.**

**Are post-construction BMPs required?**

# DESIGN EXAMPLE #3

## Private Project partially within DOT ROW

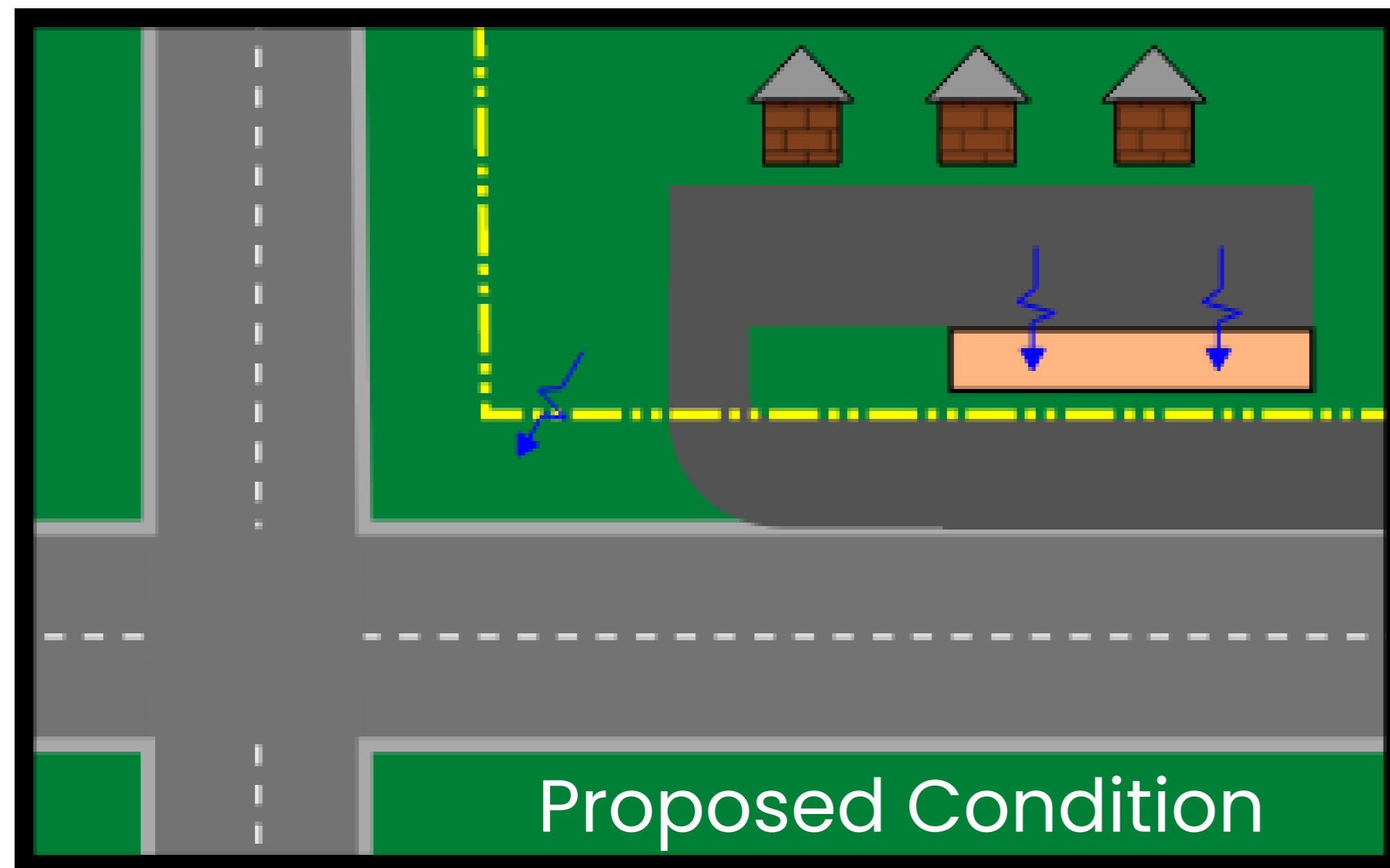

**That depends...**

**Some factors to consider:**

- What is the total disturbance area?
  - If total disturbed area > 1 AC, project will be evaluated for post-construction BMPs
- How much new impervious surface is created?
  - Treat portion within DOT right-of-way regardless of size even if less than 1 AC
- Where is runoff directed?
  - If runoff remains outside of DOT ROW, no post-construction BMPs required within DOT ROW
- Is there an increase in runoff quantity?
  - Flow increase to DOT ROW needs to be addressed
- Is project within a sensitive watershed?
  - BMPs may be required to meet allowable discharge limitations
- Does project comply with County requirements?
  - Project must meet all County requirements for post-construction BMPs

# QUESTIONS?

Jason Lau, P.E., CPESC  
(808) 596-7790  
jason@tlcghawaii.com



**PROTECT  
OUR WATER**

MĀLAMA I KA WAI  
STATE OF HAWAII DEPARTMENT OF TRANSPORTATION



**TRASH  
FREE  
HAWAII**



**PROTECT OUR WATER**

- MĀLAMA I KA WAI -  
HDOT Highways Division - Maui District